



ADT®

**DVR51xxC Series
Digital Video Recorder
User Guide**





Typographic Conventions

This document uses the following typographic conventions to help you locate and identify information:

Italic text Identifies new terms, emphasis, and book titles

Bold text Identifies button names and other items that you can click or touch in the graphical user interface or press on a computer keyboard

`Mono text` Identifies text to enter on the keyboard

Note: Notes provide extra information about a topic that is good to know but not essential to the process.

CAUTION: Cautions draw your attention to actions that could compromise the security of your system or result in the loss of data.

©2014 ADT LLC dba ADT Security Services. All rights reserved. ADT, the ADT logo, 800 ADT.ASAP and the product/service names listed in this document are marks and/or registered marks. Unauthorized use is strictly prohibited.

Document Version 2.2 201405

Table of Contents

1	DVR Overview	1
1.1	Front Panel	1
1.2	Rear Panel	1
1.3	Context Menu	3
1.4	Virtual Keyboard	3
2	Commonly Used Operations	4
2.1	Login, Logout and Main Menu	4
2.1.1	Startup Sequence	6
2.1.2	Logout / Shutdown	6
2.2	Live Viewing	7
2.3	Recording	8
2.3.1	Manual Record	8
2.3.2	Basic Operation	9
2.3.3	Enable/Disable Record	9
2.3.4	Manual All Channel Recording	9
2.3.5	All Channel Schedule Recording	10
2.3.6	All Channel Manual Recording	10
2.3.7	Stop All Channel Recording	11
2.4	Search and Playback	12
2.4.1	Other Functions	15
2.4.2	Smart Search	16
2.4.3	Playback by Time	17
2.4.4	Mark Playback	18
2.5	Schedule	20
2.5.1	Schedule Menu	20
2.5.2	Snapshot	22
2.5.3	Image FTP	26
2.6	Detect	26
2.6.1	Detect Setup	26
2.6.2	Video Loss	32
2.6.3	Camera Masking	34
2.7	Backup	37
3	Menu Operations	40
3.1	Menu Tree	40
3.2	Main Menu	41
3.3	Setting	41
3.3.1	General	42
3.3.2	Encode	45

3.3.3	Schedule.....	48
3.3.4	Network.....	49
3.3.5	Detect.....	67
3.3.6	Display.....	68
3.3.7	Default.....	70
3.4	Search.....	70
3.5	Advanced.....	71
3.5.1	HDD Management.....	71
3.5.2	Abnormality.....	74
3.5.3	Record.....	75
3.5.4	Account.....	75
3.5.5	Auto Maintenance.....	79
3.5.6	TV Adjust.....	79
3.5.7	Text Overlay.....	80
3.5.8	Config Backup.....	83
3.6	Information.....	84
3.6.1	HDD Information.....	85
3.6.2	BPS.....	86
3.6.3	Log.....	86
3.6.4	Version.....	87
3.6.5	Online Users.....	88
3.6.6	Network Information.....	89
3.7	Shutdown.....	91
4	Web Service.....	92
4.1	Network Connection.....	92
4.2	Login.....	92
4.3	Live Tab.....	94
4.3.1	LAN Mode.....	95
4.3.2	WAN Mode.....	98
4.3.3	Real-time Monitor.....	100
4.4	Playback Tab (Search).....	100
4.5	Alarm.....	105
4.5.1	Alarm Type.....	105
4.5.2	Operation.....	105
4.5.3	Alarm Sound.....	105
4.6	Setup.....	105
4.6.1	Channel.....	105
4.6.2	Network.....	112
4.6.3	Event.....	124
4.6.4	Storage.....	134
4.6.5	System.....	141

4.6.6	Advanced	156
4.6.7	Information.....	160
4.7	Logout.....	162
4.8	Un-install Web Control.....	162
Appendix A Troubleshooting and Daily Maintenance		163
Appendix B Specifications		167
Appendix C Compatible Backup Device List.....		170
Appendix D Compatible CD/DVD Device List		174
Appendix E Compatible Display List		175
Appendix F Compatible Switcher List.....		176
Appendix G Compatible Wireless Mouse List.....		177
Index.....		178

Preface

Welcome

Thank you for purchasing the ADT® DVR5 1xxC Series digital video recorder. The ADT DVR5 1xxC Series is available in the following models:

- DVR5104C—4 channel DVR
- DVR5108C—8 channel DVR
- DVR5116C—16 channel DVR

This user guide is designed to be a reference tool for the installation and operation of your system. Here you can find information about this series DVR features and functions, as well as a detailed menu tree. Before installation and operation read the following safeguards and warnings carefully.

Important Safeguards and Warnings

Electrical Safety

All installation and operation here should conform to your local electrical safety codes.

We assume no liability or responsibility for all the fires or electrical shock caused by improper handling or installation.

Transportation security

Heavy stress, violent vibration or water splash are not allowed during transportation, storage and installation.

Installation

- Keep upright.
- Handle with care.
- Do not apply power to the DVR before completing the installation.
- Do not place objects on top of the DVR.

Qualified Service Personnel

All examination and repair work should be performed only by qualified service personnel.

Environment

The DVR should be installed in a cool, dry place away from direct sunlight. This series product should be stored and used in an environment ranging from 32°F to 131°F (0°C to 55°C).

Accessories

- Be sure to use only the accessories recommended by manufacturer.
- Before installation, open the package and check that all the components are included.
- Contact us if something is damaged in the package.

Lithium Battery

- When replacing the battery, make sure you are using the same model.
- Improper battery use may result in fire, explosion or personal injury.

Replacing the Button Battery

Please use the same battery model. ADT recommends replacing the battery regularly (once a year) to ensure system time accuracy. Before replacing the battery, save the system setup to avoid losing data.

Features

Overview

This DVR5 1xxC Series is an excellent digital monitor product designed for security applications. It adopts embedded Linux OS to maintain reliable operation and the H.264 compression algorithm to provide high quality, low bit streams. The unique frame-by-frame playback function is ideal for detail analysis. It has various functions such as record, playback and live monitor. The DVR5 1xxC Series features advanced technology and robust network data transmission functions.

This DVR series adopts an embedded design to achieve high security and reliability. When connected to professional surveillance software (ADT VideoView), the DVR connects to the security network for remote monitoring functions.

This series product can be widely used in various areas such as banking, telecommunication, electric power, interrogation, transportation, intelligent resident zone, factory, warehouse, resources and water conservation.

This series DVR features:

- **Real-time Monitor**
 - Analog output port, VGA port and HDMI port
 - Supports TV, VGA and HDMI outputs simultaneously
- **Storage function**
 - Special data format ensures data security while avoiding malicious data modification
- **Compression format**
 - Supports multiple-channel video
- **Backup function**
 - Supports backup operation via the USB port (such as flash drive, portable HDD or burner)
 - You can also download the file to a local HDD for backup via network
- **Record / Playback function**
 - Each channel records independently and at the same time can support search, forward play, network monitor, record search and download functions
 - Supports various playback modes: slow play, fast play, backward play and frame-by-frame playback
 - Supports time-of-day text overlay so that you can view event time and camera name
 - Supports specified zone enlargement
- **Network Operation**
 - Supports network remote real-time monitor and remote search

- **Communication Port**
 - Standard Ethernet port provides network access
 - Dual Ethernet ports support advanced configuration modes such as multiple access, fault tolerance and load balancing
- **Intelligent Operation**
 - Supports USB mouse operation
 - Supports copy and paste functions
- **UPnP**
 - Establishes the mapping relationship between the LAN and the WAN via the Universal Plug and Play (UPnP) protocol

Note: Slight function differences may be found among the different models in the series.
- **Auto Resume after Power Failure**
 - Following a restart after a power failure, the system automatically backs up the video and resumes from the previous working status.

Installation and Connections

Note: You should install and operate your DVR according to local electrical safety requirements.

Connecting the Power Supply

ADT recommends that you use an uninterruptible power supply (UPS) to ensure continuous operation and a longer life span for the DVR as well as for any peripheral equipment such as the cameras.

Connecting Video Input and Output Devices

- The video input interface is BNC
- The input video format includes: PAL/NTSC BNC (1.0V_{p-p}, 75Ω)
- The input video signal must have high SNR, low distortion and low interference

Ensure the stability and reliability of the camera signal

- The camera should be installed in a cool, dry place away from direct sunlight
- The camera and the DVR should use the same grounding

Ensure the stability and reliability of the transmission line

- Use high quality, sound shielded BNC
- Select a suitable BNC model appropriate for the transmission distance
- For long distances, use twisted pair cable
- Use of video compensation devices or optical fiber will help ensure video quality
- Keep the video signal away from strong electromagnetic interference, especially high current sources
- The signal line and shielded wire should be secured firmly and have a good connection

Connecting the Video Output

The video output includes a BNC (PAL/NTSC 1.0V_{p-p}, 75Ω) output, a VGA output and an HDMI output. The system supports BNC, VGA and HDMI output at the same time.

When you are using a CRT type monitor to replace the system monitor, note the following:

- To lengthen monitor life, turn off when not in use
- Demagnetize the monitor on a regular basis
- Keep the monitor away from devices with strong electromagnetic interference
- A television set is not a reliable substitute for a video output device. TVs also require reduced working hours and must avoid interference from power supplies and other devices.

1 DVR Overview

This chapter provides information about front panel and rear panel functions as well as some basic virtual controls. Refer to this section first when installing the DVR.

1.1 Front Panel

The front panel has a USB port and three LED indicators. The front panel for the 4-channel model DVR5104C and 8-channel model DVR5108C is shown in Figure 1-1. Although the 16-channel model DVR5116C is wider, the USB port and indicators are in the same position.

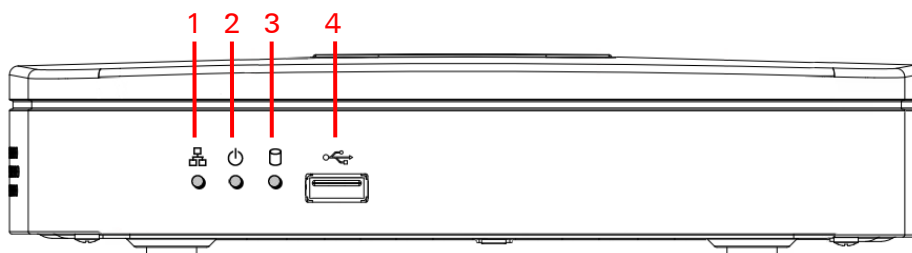





Figure 1-1

Refer to the following table for detailed information.

Item	Symbol	Function
1		Network indicator. LED glows red to alert you of a network error or that there is no network connection.
2		Power indicator. LED glows red when the unit is powered on.
3		HDD indicator. LED glows red to alert you of a hard disk error or that disk capacity is below the specified threshold value.
4		USB port. An additional USB port is installed on the Rear Panel.

1.2 Rear Panel

The rear panel of the DVR-5 1xxC Series varies slightly by model. The 16-channel model is wider than the 4-channel and 8-channel models.

The 4-channel model DVR5104C rear panel is shown in Figure 1-2 below.

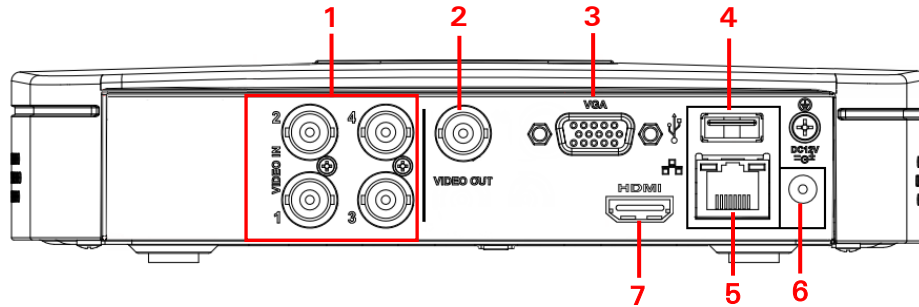

Figure 1-2

The 8-channel model DVR5 108C rear panel is shown in Figure 1-3 below.

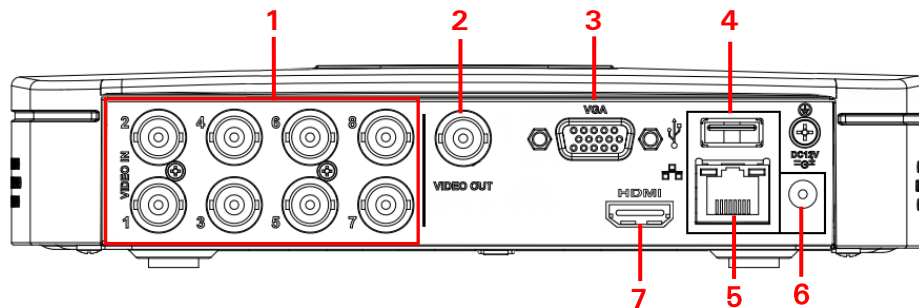

Figure 1-3

The 16-channel model DVR5 116C rear panel is shown in Figure 1-4 below.

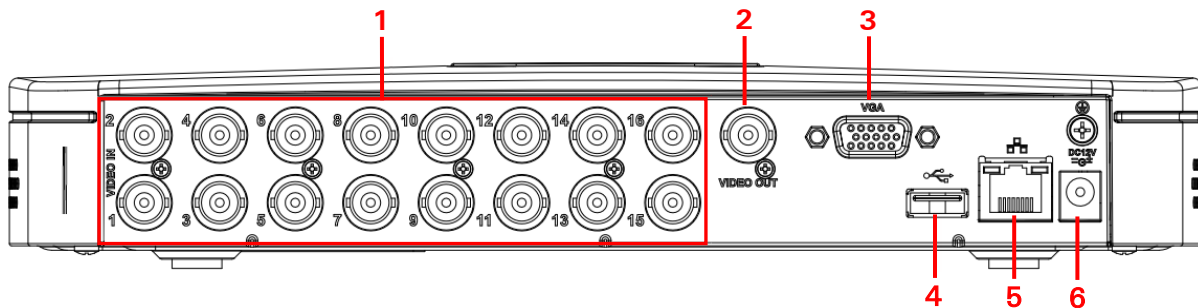

Figure 1-4

Refer to the following table for detailed information.

Item	Function
1	Video input
2	Video output
3	VGA output
4	USB port
5	Network port
6	Power socket
7	HDMI port

Note: When connect the Ethernet port, use the crossover cable to connect the PC and use the straight cable to connect to the switcher or router.

1.3 Context Menu

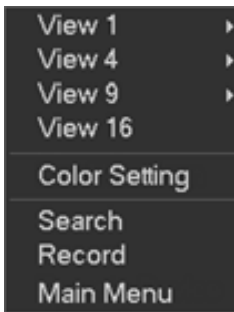

The context menu provides easy access to commonly used menu operations.

Right mouse-click to open the context menu. These options are available:

- Multiple View mode
- Color Setting
- Search and Playback
- Record functions
- Main Menu

1.4 Virtual Keyboard

The system displays three input modes: upper case and lower case alpha characters and numeric.

Switch between modes by clicking the button to the right of the field. It toggles from **abc** to **ABC** to **123**.

Select **abc** to display lower case letters and numbers. **␣** functions as a space and **←** functions as a backspace. You can also click the **Shift** key to toggle to this keyboard.

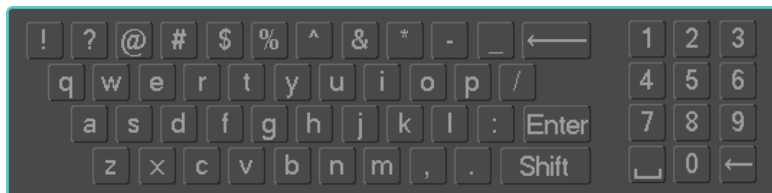

Select **ABC** to display upper case letters and numbers. **␣** functions as a space and **←** functions as a backspace. You can also click the **Shift** key to toggle to this keyboard.

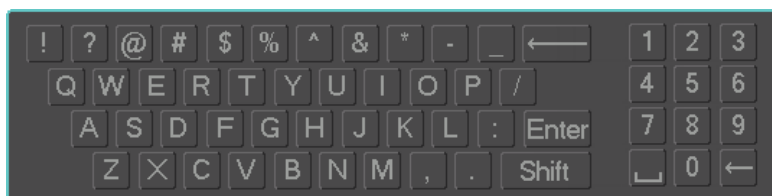

Select **123** to display numeric characters only. **␣** functions as a space and **←** functions as a backspace. This keypad appears *only* when the entry must be numeric.

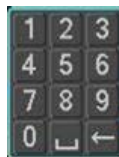

Note: Because the numeric pad appears on both upper case and lower case virtual keyboards, you do not need to change keyboards to make numeric entries at login.

2 Commonly Used Operations

This section describes how to startup and login to the system, as well as how to set up and perform the most commonly-used operations. For information on the full menu set, refer to section **3 Menu Operation** on page 40.

2.1 Login, Logout and Main Menu

1. Apply power to the DVR.

After the system has booted up, the Startup Wizard appears on the display monitor to have you set up some basic system parameters. If you do not want the Startup Wizard to appear the next time you start up the system, clear the **Startup** box.

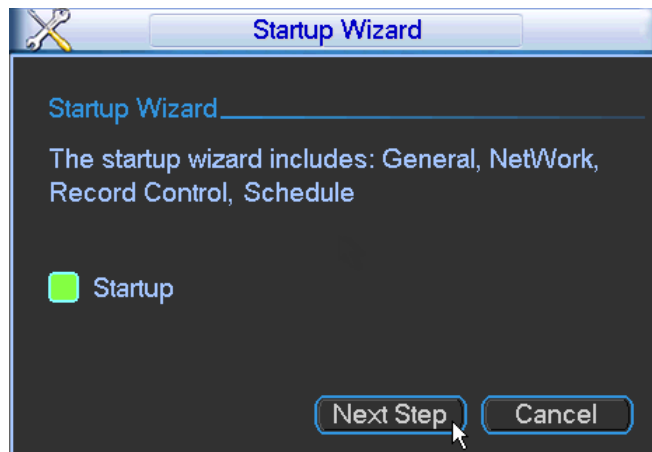

Figure 2-1

2. Click the **Next Step** button. The System Login dialog appears.



Figure 2-2

The login of four accounts:

- **User Name:** admin. **Password:** admin. (administrator, local and network)
- **User Name:** 888888. **Password:** 888888. (administrator and local only)
- **User Name:** 666666. **Password:** 666666(Lower authority user who can only use monitor, playback, backup, etc.)
- **User Name:** default. **Password:** default (hidden user)

- Use the USB mouse or remote control to complete the login.

Using the USB Mouse:

- Use the USB mouse to select one of the **User Names** from the Drop-down menu.
- Click in the **Password** field. The virtual keyboard appears.

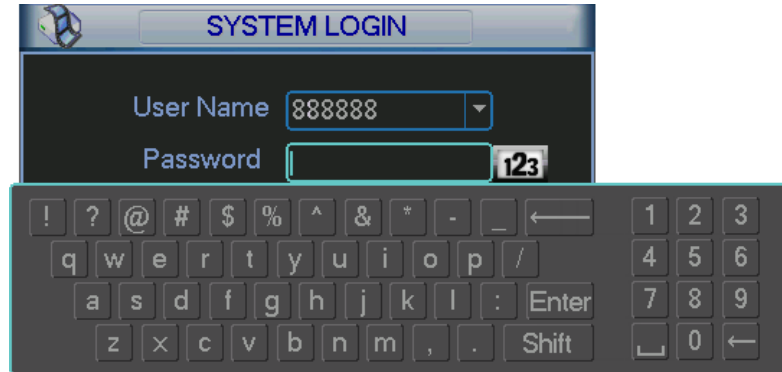

Figure 2-3

- Toggle the **ABC/ abc** button or **Shift** key to select between upper or lower case letters.

Note: Because the numeric pad appears on both upper case and lower case virtual keyboards, you do not need to change keyboards to make numeric entries.

- Select the desired alpha/numeric character. It turns green and enters the **Password** field.
- Repeat until all characters are entered.
- Click **Enter** on the virtual keyboard. The keyboard disappears.
- Click **OK** on the System Login dialog to enter. The Main Menu appears.

Using the Remote Control:

- Press Enter. The SYSTEM LOGIN dialog appears. Press Esc to remove the dialog.
- The User Name field is highlighted in light blue. Use the ▲ and ▼ arrow keys to select the desired user name.
- Use ► arrow key to shift to the Password field. It is highlighted in light blue.
- Press the **Shift** key to toggle between upper case letters, lower case letters or numeric input.
- Use the keypad on the remote to enter the desired characters.
- Press the **Enter** key on the remote. The keyboard disappears and the Main Menu appears.

Note: For security reasons, modify your password after your first login.

- Three (3) sequential login failures will result in a system alarm
- Five (5) sequential failures will result in account lock

2.1.1 Startup Sequence

After login, the Startup Wizard gives you the option of setting up some basic system parameters. You can enter this information now or at a later time, as follows:

- **General**, as described on page 42
- **Network**, as described on page 49
- **Schedule**, as described on page 48

1. For each option, click **Next Step** to move to the next dialog or **Pre Step** to return to the previous.
2. After completing the final dialog, click **Finished**. A popup message says Startup Finished. Click **OK** to accept.
3. If you click **Cancel** to exit the startup sequence, a popup message asks if you are sure. Click **OK**.
4. If you do not want the Startup Wizard to appear the next time you start up the system, clear the **Startup** box.

2.1.2 Logout / Shutdown

1. In the Main Menu, click the **Shutdown** button. The SHUTDOWN dialog appears.



Figure 2-4

2. Use the drop-down list to select the desired option.

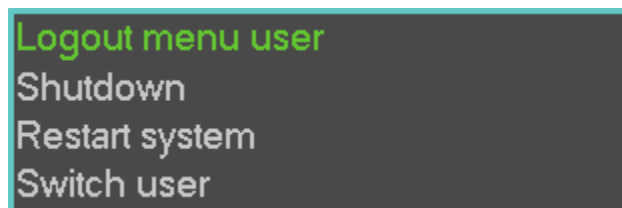

Figure 2-5

3. Enter the username and password to complete the operation.
4. Click **OK**.

2.2 Live Viewing





After you log in, the system is in live viewing mode. You will see the system date, time and channel name. You can change the system date and time in the General Settings Menu (*Main Menu > Setting > General*). To modify the channel name, navigate to the Display settings (*Main Menu > Setting > Display*).

Note: You can return to live viewing from any other mode by right-clicking the mouse or by pressing the Esc key on the front panel or on the remote control.

Right-click the mouse and use the context menu to select the configuration you want to display. View 1 for single channel or View X for multi-channel display. While in multi-channel mode, double click on a channel to view it in single channel mode.

Note: To return to the previous menu, right-click the mouse or press the Esc key on the front panel or on the remote control.

The following icons appear on the monitor screen.

- | | | | | | |
|---|---|------------------|---|---|-------------|
| 1 |  | Recording mode | 3 |  | Video loss |
| 2 |  | Motion detection | 4 |  | Camera lock |



TIP: During multiple-channel mode, you can change position of cameras on the screen. For example, left mouse click on the camera on channel 1, drag it to the channel 8 position and release the mouse button. Channel 1 and channel 8 switch positions.



Live Mode Control Bar

Hover the cursor over the top center of the video in any channel. The live mode control bar appears. The control bar automatically hides after 6 seconds of inactivity.



Figure 2-6

No.	Name	Function
1	Instant playback	Plays back the previous 5-60 minutes of recording for the current channel. Click the X at the bottom of the window to stop the playback and return to real time. Navigate to <i>Main Menu > General</i> to set real-time playback time.
2	Digital zoom	Zooms in on the current channel. The selected area displays the  icon; the free area is shown with 

3	Real-time backup function	<p>Backs up the video of the current channel to the USB device. The system cannot backup the video of multiple channels at the same time.</p> <p>The currently selected backup channel displays  and the free channel is shown with .</p> <p>Once the backup starts, the free channel is shown with the  icon.</p>
4	Exit	Close the live mode control bar

Instant Playback

The playback control supports the Play, Pause, and Exit and Drag functions.

- During the playback process, you cannot see the channel name and recording status of the current channel. The channel name and recording status reappear after you click the **X** to exit playback mode.
- During the playback, you cannot switch the displayed channel or change current window-display mode.

Note: The tour function has higher priority than the instant playback. You cannot control the playback until the tour function has ended.

2.3 Recording

Note: You must have proper rights to implement the following operations.

2.3.1 Manual Record

This feature enables you to immediately begin recording. The manual record function overrides the automatic recording settings. There are two ways for you to access the Manual Record screen.

- Right click the mouse and select **Record**, or
- Navigate to *Advanced* > *Record* in the main menu.
- In live viewing mode, click the **Record** button on the remote control.

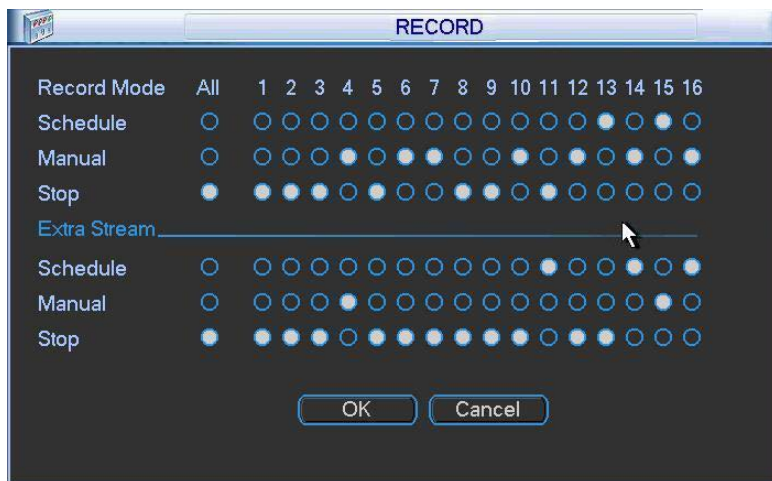

Figure 2-7

2.3.2 Basic Operation

Highlight the icon to select corresponding channel for the desired mode. Alternatively, click **All** to set all channels to the desired mode.

There are two modes of operation:

- Main stream, in the upper half of the dialog
- Extra stream, in the lower half of the dialog

There are three statuses:

- Schedule
- Manual
- Stop

Schedule. The channel records for the period you have set up (*Main Menu > Setting > Schedule*)

Manual. The channel records immediately until you select **Stop**. Manual recording has highest priority.

Stop. All channels stop recording.

2.3.3 Enable/Disable Record

Current channel status is indicated by the corresponding icon:

- (filled) means the channel is in recording mode,
- (empty) means that it is not in recording mode.

Use the mouse to highlight the desired channel number. See Figure 2-8.

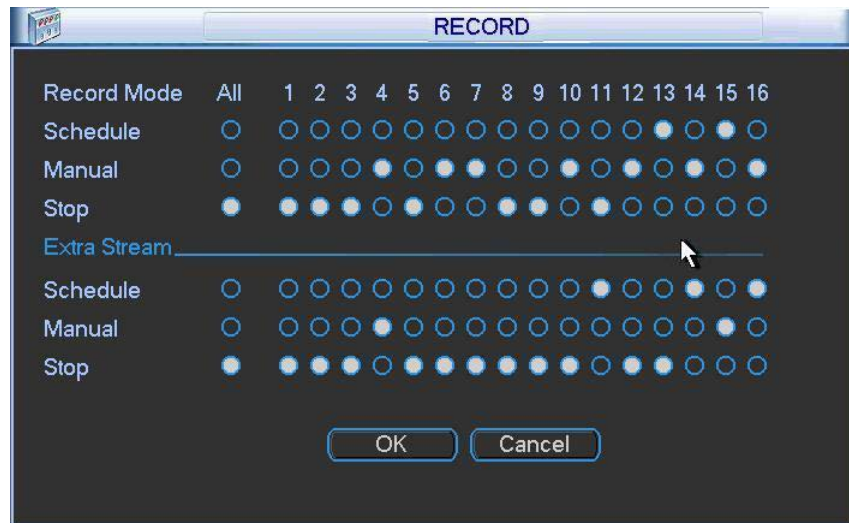

Figure 2-8

2.3.4 Manual All Channel Recording

Highlight the below **All** and to the right of **Manual** to enable manual recording on all channels.

2.3.5 All Channel Schedule Recording

Highlight the below **All** and to the right of **Schedule** to schedule recording on all channels. See Figure 2-9.

When system is in schedule recording, all channels will record as you have previously set (*Main Menu>Setting>Schedule*).

The HDD light () on the front panel illuminates, indicating that the hard drive is active due to the recording session.

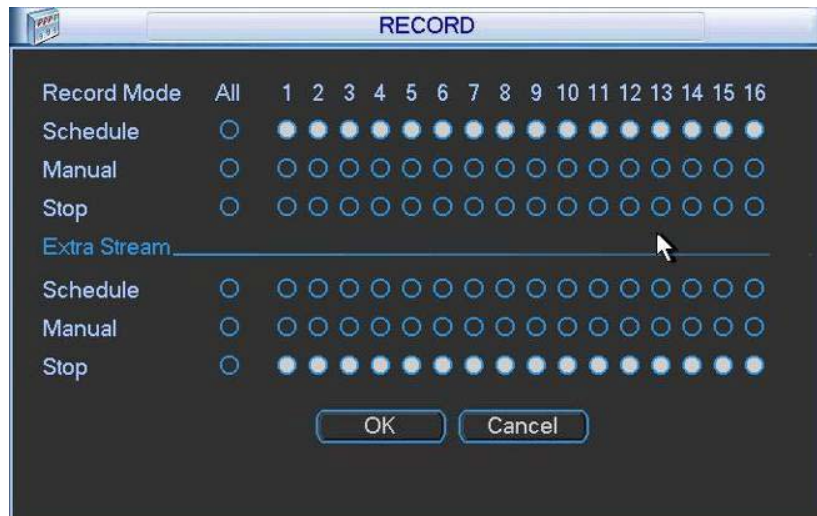

Figure 2-9

2.3.6 All Channel Manual Recording

Highlight the below **All** and to the right of **Manual**. See Figure 2-10.

When the system is in Manual recording, all scheduled recordings are superseded. (*Main Menu>Setting>Schedule*).

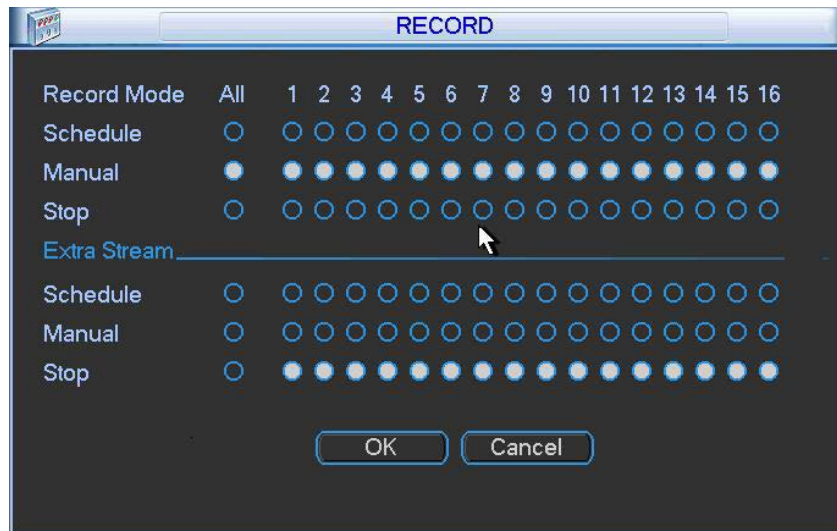

Figure 2-10

2.3.7 Stop All Channel Recording

Highlight the below **All** and to the right of **Stop**. See Figure 2-11.

The system stops all channel recording no matter what mode you have set in the menu (*Main Menu>Setting>Schedule*).

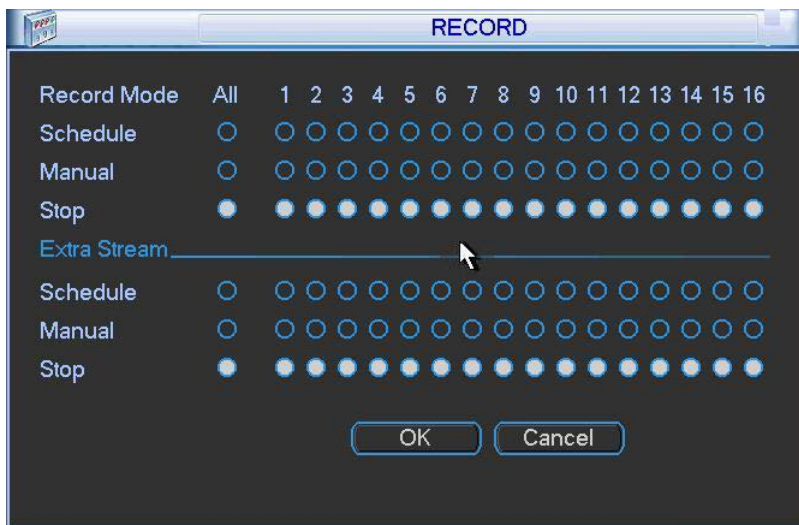



Figure 2-11

2.4 Search and Playback

Click the **Search**  button in the Main Menu, or else right click the mouse and select Search from the context menu. The Search screen appears.

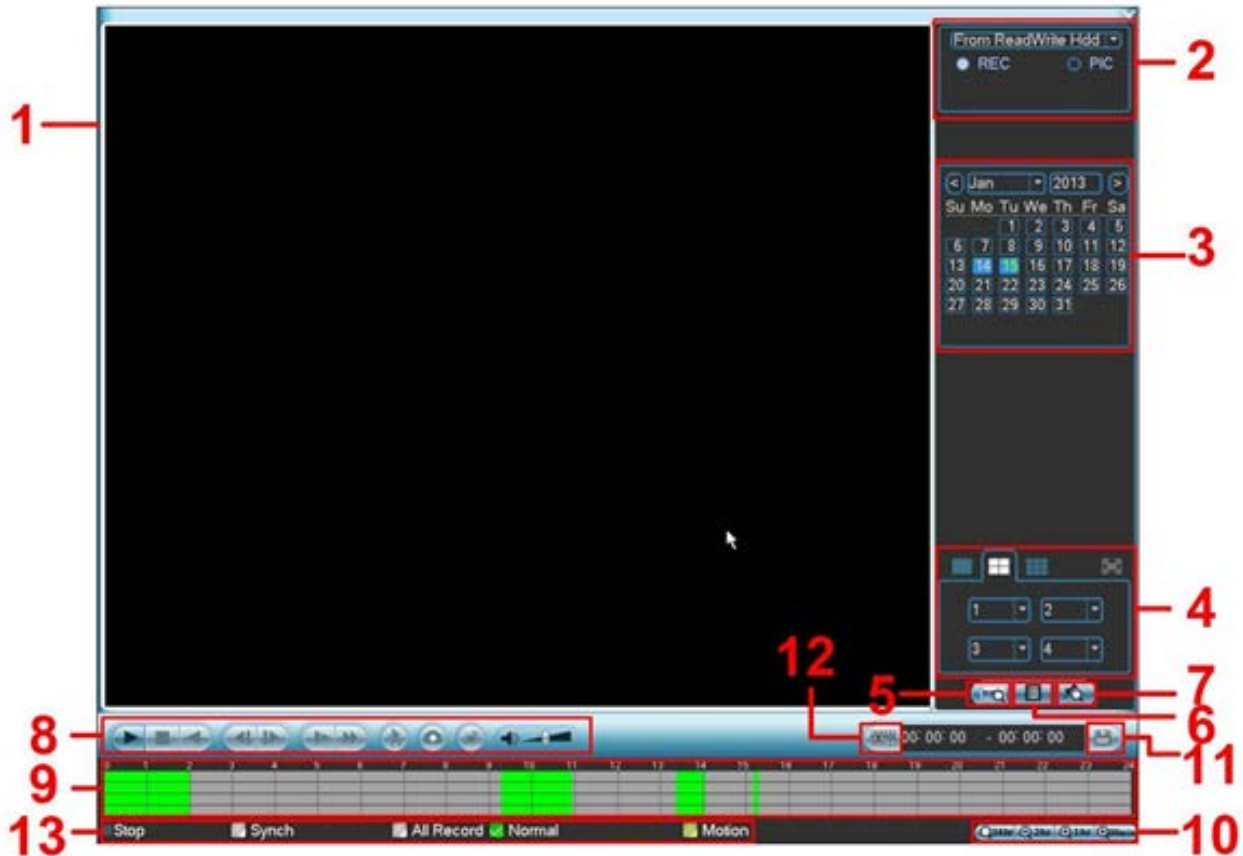

Figure 2-12





There are two file types:





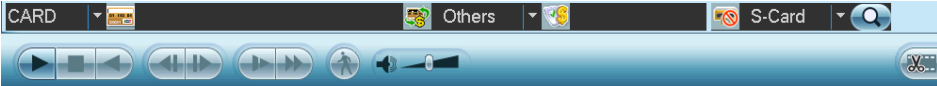



R: Regular recording file



M: Motion Detection recording file

Refer to the following table for detailed information.

No.	Name	Function
1	Display window	The recorded file or snapshot picture is displayed here. The DVR5 1xxC Series supports 1, 4, 9, and 16-window playback.
2	Search type	Select the desired file: <ol style="list-style-type: none"> Highlight the <input type="radio"/> for the file type: REC for recording or PIC for picture. Use the drop-down menu to select the source. You can select to play from the Read-Write HDD or from the peripheral device, if connected. Click the Browse button to view the record files in the root directory of the peripheral device, and then select the file you want to play.
3	Calendar	In any play mode, click the date you want to see files for. The corresponding record file trace appears in the time bar. If a date is highlighted in blue date, a picture or file exists for this date.

No.	Name	Function
4	Playback mode and channel selection	<p>Playback mode: 1/4/9/16, depending on your model:</p> <ul style="list-style-type: none"> • In 1-window playback mode: select one channel between 1-16 • In 4-window playback mode: select 4 channels • In 9-window playback mode, switch between channels 1-8 and 9-16 • In 16-window playback mode, channels 1-16 are displayed <p>The time bar changes after you modify the playback mode or the channel option.</p>
5	Credit card number search	<p>Click to view card number/field setup bar and implement advanced search.</p> 
6	File list switch	<p>File List</p> <ul style="list-style-type: none"> • Click to view the picture/record file list for the current day. • File type: R—regular record; M—Motion detect record. • The file list displays the first channel of the recording file. • The system can display a maximum of 128 files at one time. • Use ◀ and ▶ or the mouse to view the file. Select one item, and then double click the mouse or click the ENTER button to playback. • Click in the time field and manually enter a time frame. Click the search button to initiate an accurate search.  <p>Lock File</p> <ul style="list-style-type: none"> • Click the file you want to lock and click the button  to lock. The file you lock cannot be overwritten. • Search locked file: Click the button  to view the locked file list. <p>Note</p> <ul style="list-style-type: none"> • The system can lock a maximum of 16 files. • The size of the locked file must be less than 1/4 of the HDD total space. • The first 16G of each partition cannot be locked. • The system can only lock one file at one time. • The system cannot lock extra stream. • The file that is currently being written or overwritten cannot be locked. <p>Return</p> <p>Click the  button to return to the calendar and channel setup screen.</p>
7	Mark file list button	Click to bring up a list of marked files. You can view all mark information of the current channel by time.
8	Playback control panel	<p>Normal Play/Pause</p> <p>There are three ways for you to begin playback:</p> <ul style="list-style-type: none"> • Click ▶ / • Double click the desired segment of the time bar • Double click the item in the file list • In slow play mode, click to switch between play/pause. <p>■ Stop</p>

No.	Name	Function
		<p>Reverse Play  In normal play mode, left click the button, the file begins backward play. Click again to pause the current playback. In backward play mode, click ► / to restore normal play.</p>
		<p>Previous Play  <ul style="list-style-type: none"> • In playback mode, click to play the previous section. • Click continuously while watching the files from the same channel. • While paused in normal play mode, click for frame by frame playback • In frame by frame playback mode, click ► / to restore normal playback </p>
		<p>Next Play  <ul style="list-style-type: none"> • In playback mode, click to play the next section. • Click continuously when you are watching the files from the same channel. • While paused in normal play mode, click for frame by frame playback • In frame by frame playback mode, click ► / to restore normal playback. </p>
		<p>Slow Play  In playback mode, click this button to incrementally slow down the playback speed,</p>
		<p>Fast Play  In playback mode, click this button to incrementally speed up the playback speed,</p>
		<p>Note: The actual play speed depends on the software version.</p>
		<p> Click to initiate motion detection Smart Search. See section 2.4.2 Smart Search on page 16.</p>
		<p> Adjusts the Volume of the playback.</p>
		<p>Click in full-screen mode to create a snapshot picture of the record.</p> <ul style="list-style-type: none"> • Connect the peripheral device. • Click the Snapshot button in full-screen mode. • Select or create path to save the file. • Click the Start button. The snapshot picture is saved to the specified path.
		<p> When in playback mode, click this button to Mark the record. This feature is not available in all models.</p>
9	Time bar	<p>Displays the record type and time period in the current search criteria.</p> <ul style="list-style-type: none"> • In 4-window playback mode, there are corresponding four time bars. In other playback modes, there is only one time bar. • Use the mouse to click one point of the color zone in the time bar, and the system begins playback. • Green shading indicates a regular record file; yellow shading indicates a motion detection record file.

No.	Name	Function
10	Time bar unit	Use this feature to set the range of the time bar for playback. The options are: 24H, 12H, 1H and 30M. The smaller the unit, the larger the zoom. The time bar begins at 0 hour when setting the configuration, and then zooms in on the current period during playback.
11	Backup	<ol style="list-style-type: none"> 1. Select the file(s) you want to backup from the file list. 2. Click the Backup button. The backup menu appears. 3. Browse to or create a new destination folder. 4. Click the Start button to begin the backup operation. The record file(s) are saved to the specified folder. <p>The system can display a maximum of 32 files from one channel. Only backup operation can be run at one time.</p>
12	Clip	<p>Use this button to edit the file currently playing. You can clip for one channel or multiple-channels.</p> <ol style="list-style-type: none"> 1. Click the Clip button. 2. Adjust the slide bars  or  in the time bar for the corresponding channel to set the file end time, or else manually input the time. 3. Click the Clip button again to edit the second period. 4. Click the Backup button to save the current contents in a new file. <p>Note: The system supports a maximum of 1024 backup files at the same time. You cannot operate clip operation if any file has been checked in the file list.</p>
13	Recording type	<p>In any play mode, the time bar will change once you modify the search type.</p> <p><input type="checkbox"/> Synch. Check the checkbox to enable synchronized playback, whereby changing the search time period for one channel switches the playback for the other channels being displayed to the same point in time.</p>

2.4.1 Other Functions

Channel Synchronization

By checking the Synch checkbox, playback on all displayed channels are synchronized to the same time period. If unchecked, playback times for each channel are independent of each other.

Digital Zoom

When the system is in full-screen playback mode, left click the mouse in the screen. Drag your mouse in the screen to select a section and then left click mouse to zoom in. Right click the mouse to exit.

Manually Switch Channel during Playback

During the file playback process, you can switch to other channel via the dropdown list or by rolling the mouse. This function is not valid if there is no recording file or Smart Search is in progress.

Note: Some DVR versions do not support all functions (such as playback speed, channel, time and progress).

2.4.2 Smart Search

While the DVR is in playback mode, you can select the smart search feature enables you to search for and playback motion detect files.

To use the Smart Search feature:

1. During multiple-channel playback mode, double click a channel, and then click the  button, located in the Playback control panel (item #8 in Figure 2-12 on page 12). A grid appears on the screen.

Note: The system supports 396(22*18 PAL) and 330(22*15 NTSC) zones.

2. Left click the mouse and drag to select smart search zones, that is, the areas on the image where you want to search for motion activity. See Figure 2-13. There is no motion detection zone by default—you must select one.

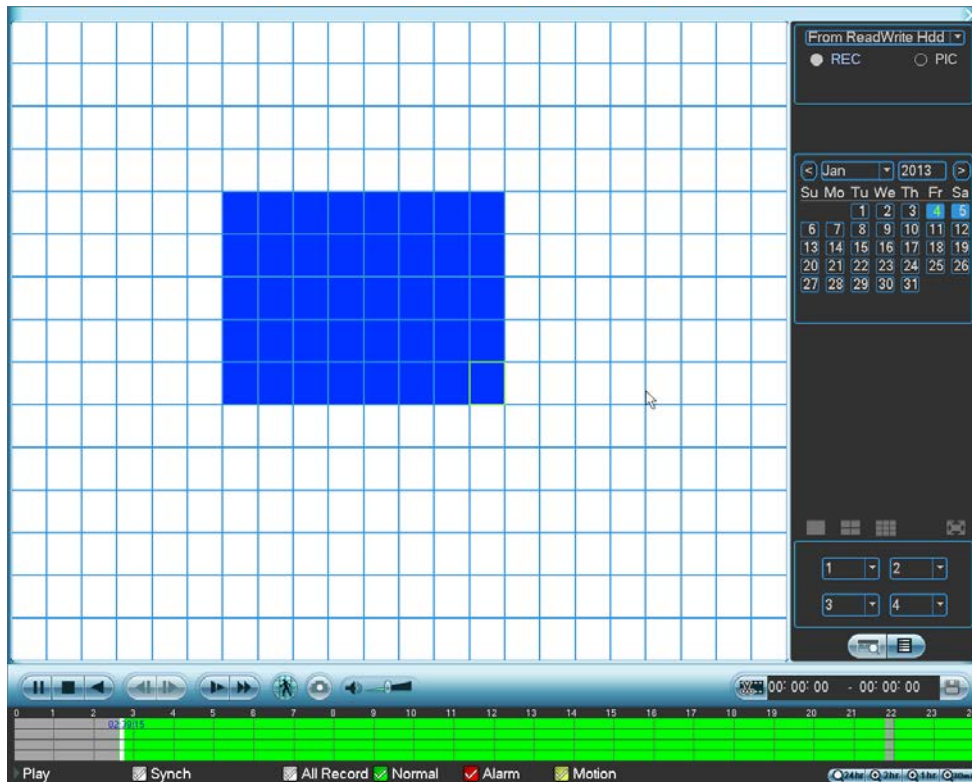



Figure 2-13

3. Click the  button to initiate smart search playback. The DVR will fast forward to the first instance of motion detected in the selected area, and playback the video in normal speed. When the motion ceases, the playback fast forwards to the next instance of motion detection and repeats the process.
4. If you select another file in the file list to play, the system plays that file.
5. Click  again to stop Smart Search playback.

During the motion detect play process, you cannot implement operations such as change time bar, begin backward playback or frame by frame playback.

IMPORTANT:

- The system does not support motion detect zone setup during the full-screen mode.
- During multiple-channel playback, system stops playback of the rest of the channels if you implement one-channel smart search.

2.4.3 Playback by Time

You can also search for recordings by time.

To search for recordings by time:

1. Select the recordings for one day.
2. Click the list. The file list interface appears.
3. Input the time for which you would like to search records in the top right corner.
4. Click **Search**. All records collected from the entered time up to the current time appear.
5. Click the Play button ►. The system begins play beginning from the specified time..

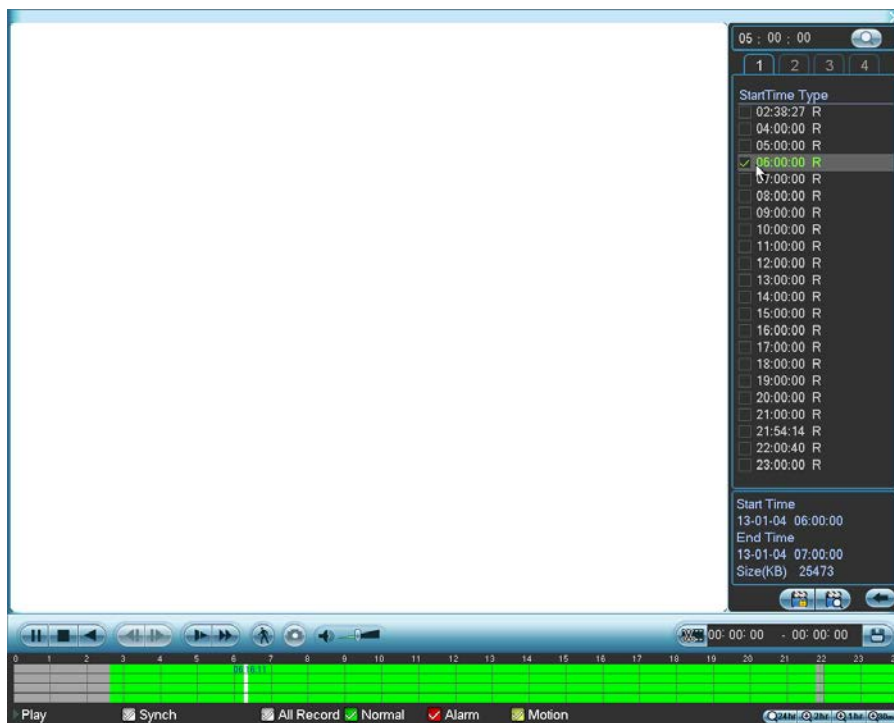

Figure 2-14

To playback recordings using the time bar:

1. Select the recordings for one day.
2. In the time bar double-click on the time of day you want to view. The vertical lines represent the hour of the day; the horizontal lines separate the channels, with channel 1 at the top.

If the Synch box is checked, playback for all channels will be for the same time period. If Synch is not checked, you can choose separate playback periods for each channel by clicking on different time periods and channels.

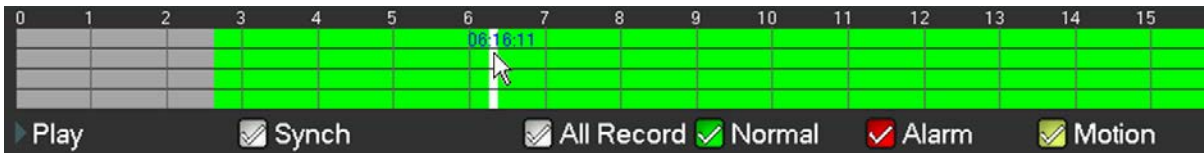



Figure 2-15

Note:

- The system does not support time playback for pictures.
- The system supports synchronization playback and non-synchronous playback. Check the Synch checkbox to enable synchronized playback.

2.4.4 Mark Playback

Note: Not all models support this function. This function is available only if you can see the mark playback icon  on the Search screen (see item 7 in Figure 2-12 on page 12.)

When you are playback mode, you can mark a recording when there is important information you would like to note. After the playback, you can use the time or the marked key word(s) to search for the corresponding recording and then play it back.

To add a Mark:

1. Click the Mark button  during playback. The Add Mark dialog appears. The **Mark Time** field is already filled in.

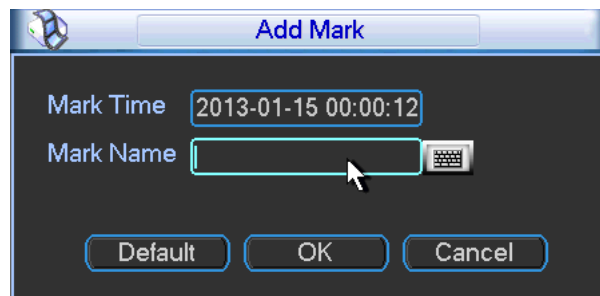



Figure 2-16

2. Click in the **Mark Name** field and type in a description for the file.
3. Click **OK**.

To playback a Mark:

1. In Search mode, select 1-window playback mode in the lower right side of the screen.
2. Select the search date from the calendar.

3. Click the mark file list button  shown in item 5 of Figure 2-12 on page 12. The Mark File List interface appears on the right side of the Search screen.
4. If desired, enter a value in seconds in the Play time before the mark field. Playback will actually begin the number of seconds you have entered before the marked time.
5. Double click one of the marked files to begin playback from the marked time.

2.4.4.1 Marks Manager

The Marks Manager manages all the marked recordings for the current channel. The manager displays all marked recordings for the current channel by time.

- Click the Marks Manager button  on The Mark File List interface. The Mark Manager screen opens, as shown in Figure 2-17.

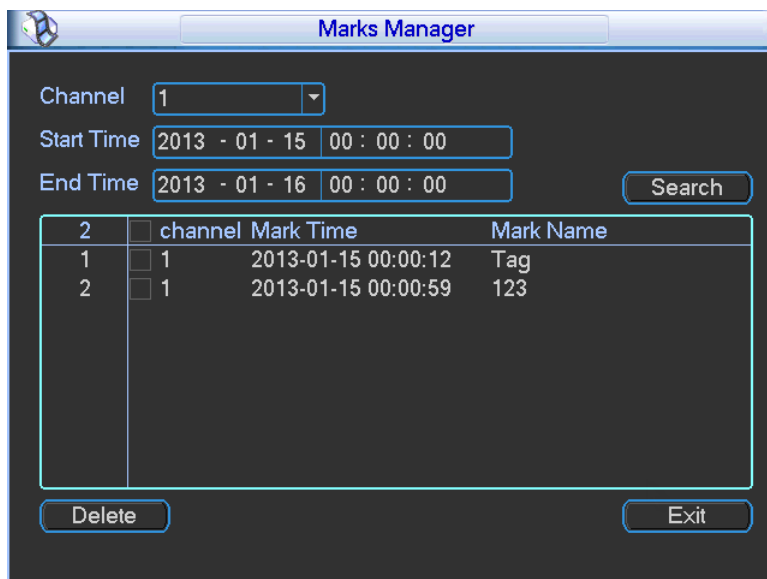

Figure 2-17

To modify a Mark Name:

1. Double click the marked item.
2. Change the Mark Name in the resulting dialog box.

To delete a record:

1. Click inside the box to the left of the marked item you wish to remove.
2. Click the **Delete** button.

Note:

- When the Mark Management screen is initiated, the current playback is paused. The system resumes playback after you exit the Mark Management screen.
- If the marked file you want to playback has been removed, the system begins playback from the first file in the list.

2.5 Schedule

You can set the recording type and time in the **Schedule** screen.

2.5.1 Schedule Menu

In the Main Menu, click the **Setting**  button and then select **Schedule**. The Schedule menu appears.

The following describes the options on the Schedule screen.

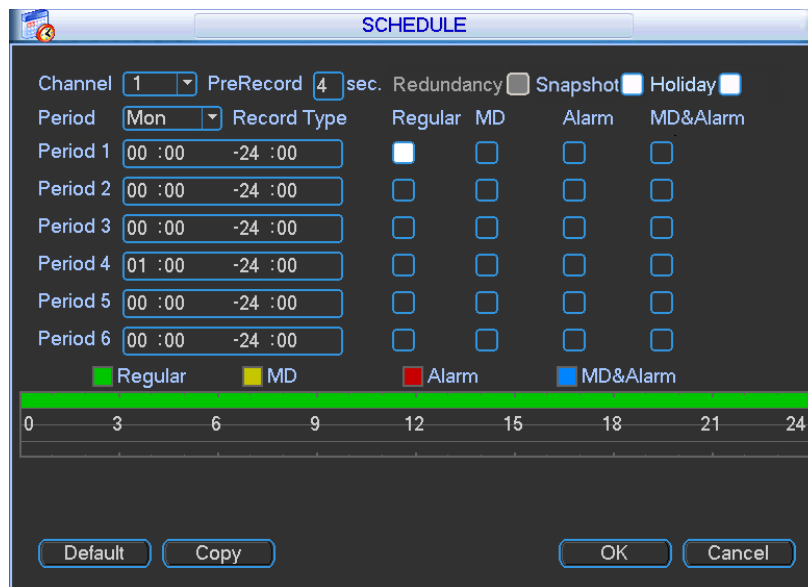

Figure 2-18

Channel. Select the channel number that you want to schedule. Select **All** if you want to set for all channels.

Pre-record. The system can pre-record the video before the event occurs into the file. The value ranges from 1 to 30 seconds depending on the bit stream.

Redundancy. Because it only supports one HDD, the redundancy function is grayed out and not available for the DVR5 1xxC Series.

Snapshot. When selected, a snapshot photo is created at the scheduled interval. For instructions on how to set up this function, see section **2.5.2.1 Schedule Snapshot** on page 22.

Holiday. Click this box to enable a unique recording schedule for the days you established as holidays in the General menu.

Period. Select the day you want to schedule: **Saturday** to **Sunday** or **All**. Select **Holiday** to schedule a unique recording schedule for the days you established as holidays in the General menu.

Period 1 - 6. You can establish up to six separate recording ranges for the selected day and channel number. For each period, enter the time of day in 24-hour format. For example, to record 10:30am to 2:00pm, enter: **10:30 -14:00**.

Record Type. Select the type of recording to be created: Regular, Motion Detection (MD), Alarm and MD with Alarm. For all types except Regular, recordings will only be created if the designated trigger condition exists (motion detection and / or alarm) during the designated day and period.

At the bottom of the menu, color bars indicate the type of recording:

- Green indicates regular recording
- Yellow indicates motion detection
- Red indicates an alarm
- Blue indicates motion detection with an alarm

To set up a regular (non-Holiday) recording schedule:

1. Select the recording channel from the **Channel** dropdown.
2. Select the recording day from the **Period** dropdown.
3. Select the recording time-of-day range(s) for the selected channel and day in the **Period 1 – Period 6** fields.
4. For each **Period 1 – Period 6** field, click the box(es) for the type(s) of files you want to record: Regular, Motion Detection and/or Alarm.
5. To record an additional 1-30 seconds prior to the scheduled time, enter the value in seconds in the **Pre Record** box.
6. To enable a photo at the scheduled interval, click the **Snapshot** box. For instructions on how to set up this function, see section **2.5.2.1 Schedule Snapshot** on page 22.

To set a recording schedule for Holidays:

Note: You must first set up the **Holiday** function in the General menu, as described in the **Holiday Setup** section on page 44.

1. Click the **Holiday** box to enable the days you established as holidays in the General menu.
2. Select the recording channel from the **Channel** dropdown.
3. Select **Holiday** from the **Period** dropdown.
4. Select the recording time-of-day range(s) for the selected channel and day in the **Period 1 – Period 6** fields.
5. For each **Period 1 – Period 6** field, click the box(es) for the type(s) of files you want to record: Regular, Motion Detection and/or Alarm.
6. To record an additional 1-30 seconds prior to the scheduled time, enter the value in seconds in the **Pre Record** box.
7. To enable a photo at the scheduled interval, click the **Snapshot** box. For instructions on how to set up this function, see section **2.5.2.1 Schedule Snapshot** on page 22.

Note: Holiday settings have priority over non-holiday schedules. If the selected day is a holiday, then the system records according to the Holiday setting. If it is not a holiday, the system records according to the regular Schedule.

2.5.1.1 Quick Setup

The Copy function enables you to copy one channel setup to another.

To use the Copy function:

1. After making your selections on the first channel, click the **Copy** button. The Copy dialog opens, as shown in Figure 2-19.

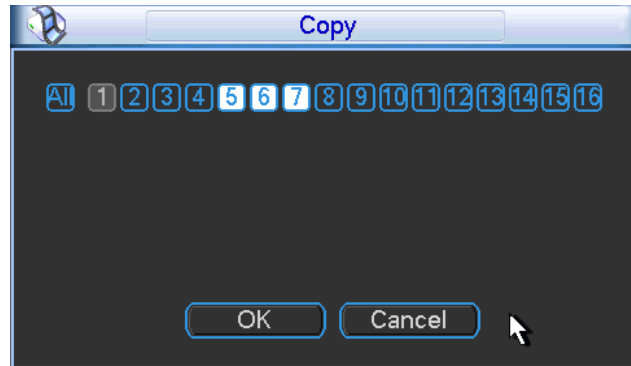

Figure 2-19

2. Select the channels into which you want to paste settings (channels 5, 6 and 7 in the figure). The current channel name is grayed out (channel 1 in the figure).
3. To apply the current channel settings to all channels, click the **All** box. The record settings of all channels become the same and the Copy button becomes hidden.
4. Click the **OK** button to save the current Copy settings. You are returned to the Record screen.
5. Click the **OK** button in the Record screen.

2.5.2 Snapshot

The DVR enables you to take a snapshot photo either at a scheduled interval or when triggered by a pre-determined event.

2.5.2.1 Schedule Snapshot

1. In the Encode screen, click the **Snapshot** button to input snapshot mode, size, quality and frequency.

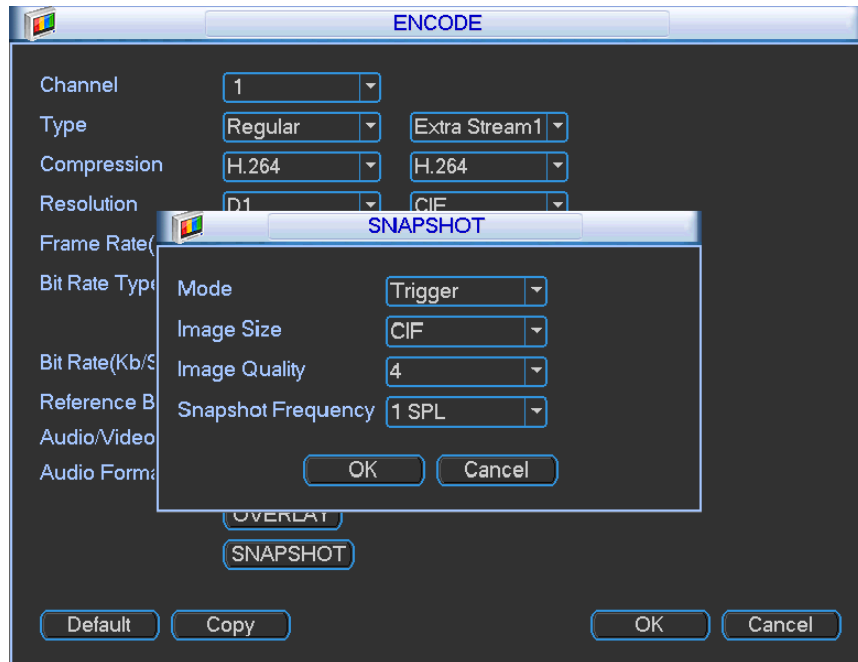

Figure 2-20

2. In the FTP screen (*Main Menu > Network > Network Setting*), input the upload interval.

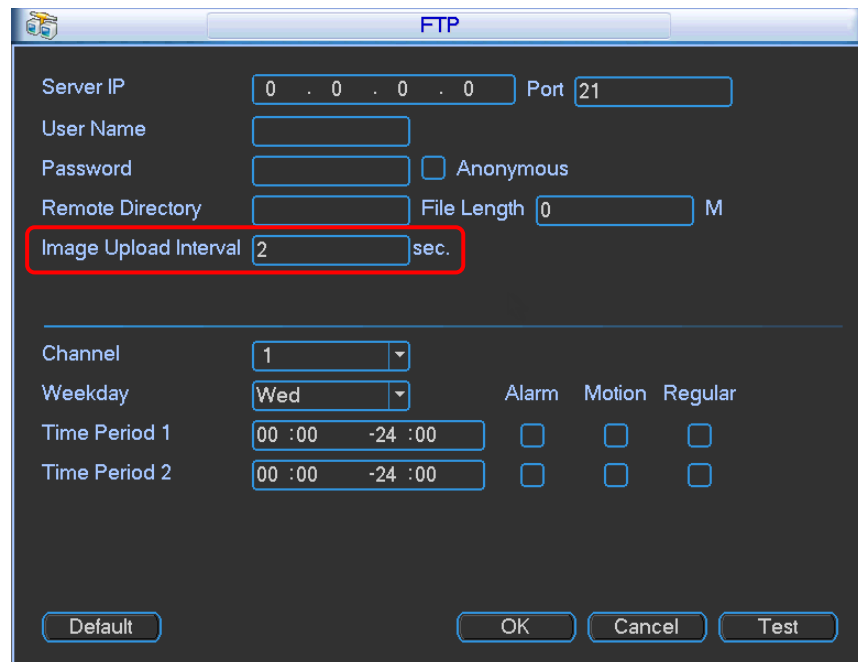

Figure 2-21

3. In Schedule screen, enable the Snapshot function by placing a check in the checkbox.

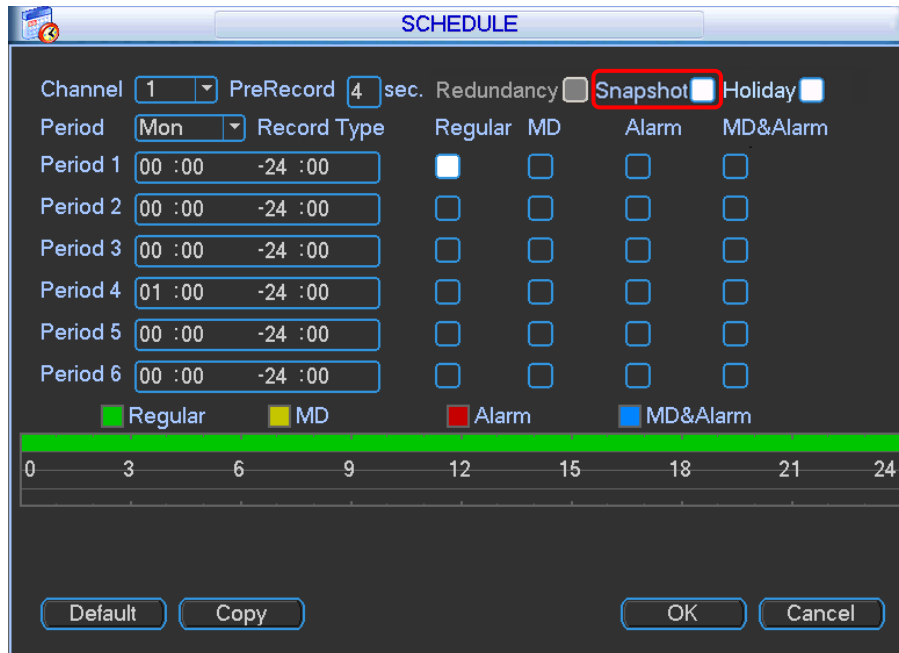

Figure 2-22

2.5.2.2 Activation Snapshot

This function triggers a snapshot when the corresponding alarm occurs.

1. In the Encode screen, click **Snapshot** to input snapshot mode, size, quality and frequency.

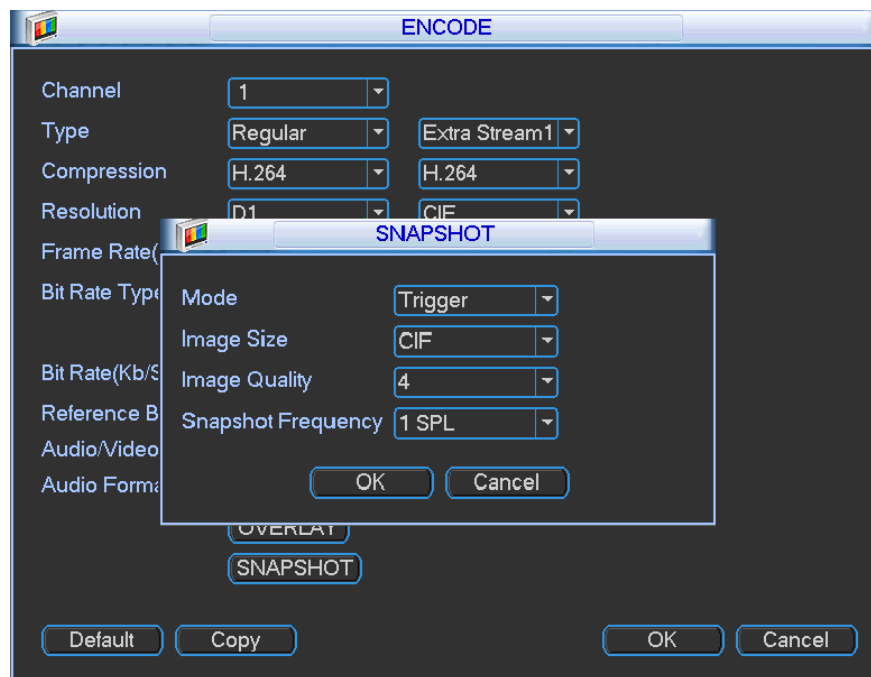

Figure 2-23

2. In the FTP screen input upload interval.

The screenshot shows the 'FTP' configuration window. The 'Image Upload Interval' field is highlighted with a red box and contains the value '2'. Other fields include Server IP (0.0.0.0), Port (21), User Name, Password, Remote Directory, File Length (0 M), Channel (1), Weekday (Wed), and Time Period 1 and 2 (00:00 -24:00). Buttons for Default, OK, Cancel, and Test are visible at the bottom.

Figure 2-24

- In the Detect screen, enable the snapshot and then specify the channels for which snapshots are to be taken.

The screenshot shows the 'DETECT' configuration window. The 'Snapshot' checkbox is checked and highlighted with a red box. Other fields include Event Type (Motion Detect), Channel (1), Enable (unchecked), Region (Setup), Sensitivity (3), Period (Setup), Anti-dither (5 sec.), Show Message (unchecked), Alarm Upload (unchecked), Send Email (10 sec.), Record Channel (1-16), Delay (10 sec.), Tour (1-16), and Buzzer (unchecked). Buttons for Default, Copy, Test, Save, and Cancel are visible at the bottom.

Figure 2-25

2.5.3 Image FTP

This feature enables the system to upload the snapshot image file to the FTP server.

1. Open the Network screen (*Main Menu > Setting > Network*).
2. Click NETWORK SETTING.
3. Enable the FTP function and double-click it to open the dialog.
4. On the FTP screen, set the FTP server information. See Figure 2-26.
5. Click the **OK** button.
6. Boot up the corresponding FTP server.
7. Enable **Schedule Snapshot** (see page 22) or **Activation Snapshot** (see page 24).

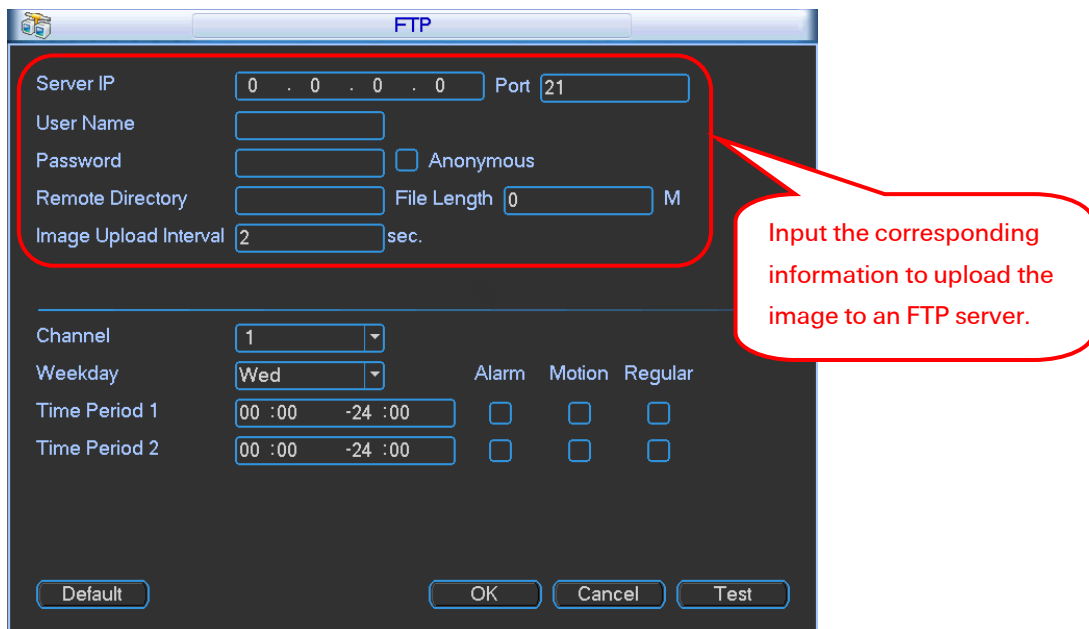

The screenshot shows the 'FTP' configuration dialog. A red callout box highlights the top section with the text: "Input the corresponding information to upload the image to an FTP server." The fields in this section are: Server IP (0 . 0 . 0 . 0), Port (21), User Name, Password, Remote Directory, File Length (0 M), and Image Upload Interval (2 sec.). There is also an 'Anonymous' checkbox. Below this section are fields for Channel (1), Weekday (Wed), and two Time Periods (1 and 2) with checkboxes for Alarm, Motion, and Regular. At the bottom are buttons for Default, OK, Cancel, and Test.

Figure 2-26

2.6 Detect

The Detect screen is used for setting up the type of events for which you want to trigger a response, such as triggering an alarm, sending an email or taking a snapshot. There are three detection types that you can set as an event:

- Motion Detection
- Video Loss
- Camera Masking

2.6.1 Detect Setup

To set up an event for triggering a response:

1. Select *Main Menu > Setting > Detect*.
The **Detect** menu appears.

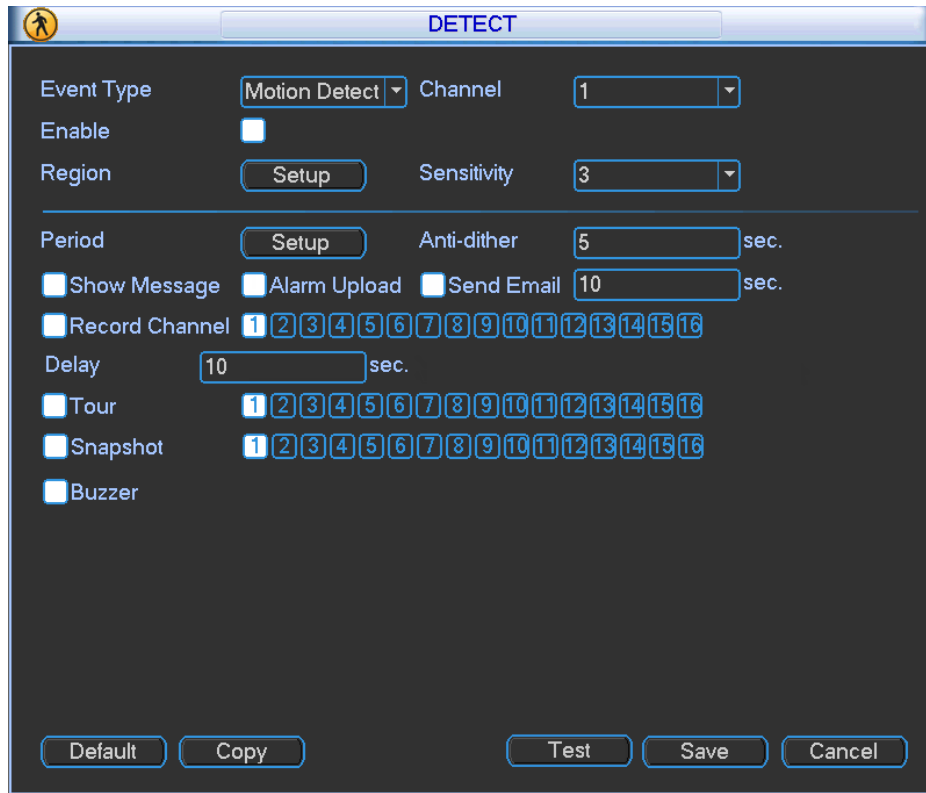

Figure 2-27

2. Highlight the box () to select the corresponding function.
3. After completing the setup, click the **Save** button.

The following describes the Detect window:

Event type

Select the desired event from the dropdown list: motion detection, video loss or camera masking.

Channel

Select a channel from the dropdown list that you want to enable for the event.

Enable

Check the box to enable the event type.

Region

(Motion Detection only) Click the **Setup** button to set Motion Detection zone. There are 396(PAL)/330(NTSC) small zones. The blue zone is the motion detection zone; the white zone is the disarmed zone. The system can only detect motion detect signal from the armed region.

Sensitivity

(Motion Detection and Camera Masking only) The system supports 6 levels. The sixth level has the highest sensitivity. The default setup is 3.

Period

Click the **Setup** button. The Period dialog opens, as shown in Figure 2-30. Here you can set the time period when detection is enabled. Select **Sunday to Saturday** from the dropdown list. Be sure to check the box to the left of the period to enable it. To set your own business day and non-business days, select work day or non-work day from the drop down list, and then click the **Setup** button. See Figure 2-31. For example, you can set Monday to Friday as working days and Saturday and Sunday as non-working days. Click the **OK** button to return to the previous screen.

Anti-dither

(Motion Detection only) This feature sets a delay period before triggering the next Motion Detection event, to avoid re-triggering on the same event. The delay period begins when the current motion detection event has ended. The system only stores one event during the anti-dither period. The value ranges from 5s to 600s.

Show Message

Enable Show Message to pop up a warning message on the local monitor to alert you that the event has occurred.

Alarm Upload

Enable this feature to upload an alarm signal to the network.

Send Email

Enable this to send out email to alert you when the event occurs.

Record Channel

The system automatically activates the designated channel(s) to record once a Motion Detection event occurs. Make sure you have set MD Record in Schedule screen (*Main Menu > Setting > Schedule*) and Schedule Record on the Manual Record screen (*Main Menu > Advanced > Manual Record*).

Delay

To avoid rerecording the same event, enter the number of seconds to wait after the event has ended before a new recording can begin. This value ranges from 10s to 300s.

Tour

Enable the tour function to present an alternating display (much like a slideshow) of the channel(s) you have set to record when a motion detect event occurs. Refer to section **3.3.6 Display** on page 68 for tour interval setup information.

Snapshot

Enable this function to take a snapshot image when a motion detect event occurs.

Buzzer

Enable this function to sound an audible tone from the DVR when the event occurs.

Note:

- In the Detect main screen, the copy/paste function is only valid for the same event type. In other words, you cannot copy a channel setup in Video Loss mode and paste it to a channel in Camera Masking mode.
- The Default function is only available for the current event type. For example, if you click the Default button in the Camera Masking dialog, only the default camera masking setup is restored to default settings. It does not affect other detection types.

2.6.1.1 Motion Detection

The system can set a Motion Detection event to trigger an alarm and initiate recording. The Motion Detect icon  appears on the live video screen if the current channel has the motion detect alarm enabled. You first must set up the area on the screen that you want to be sensitive to motion detection. You can up the motion detection zone using the mouse. You can also use keys on the front panel of the DVR: FN and arrow keys to set the detection zone, the Enter key to accept the setting, or the Esc key to exit without saving.

To set up Motion Detection:

1. Open the Motion Detect screen by selecting *Main Menu > Setting > Detect*. The Detect screen opens, as shown in Figure 2-27.
2. In the Event Type area, select the drop-down menu and select **Motion Detect**.
3. In the **Channel** area, select the channel you want to set up from the drop-down list.
4. Check the **Enable** checkbox to enable the Motion Detection feature for this channel.
5. In the **Region** field, select the **Setup** button. An interface opens for setting the motion detection zone.

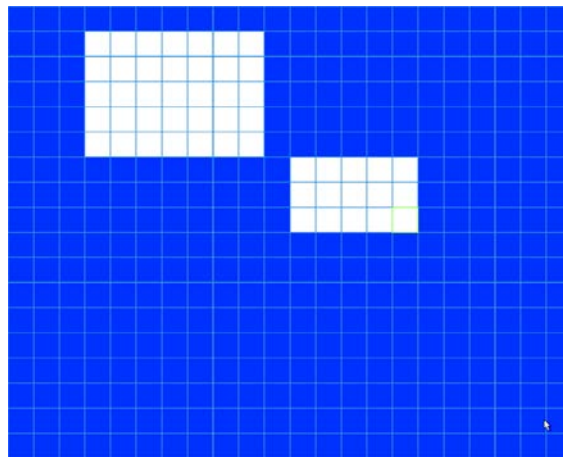
*Figure 2-28*

The blue zone is the armed (motion detection) zone; the clear zone is the disarmed zone. The system only detects motion in the blue armed region. The default setup is the entire screen (all blue).

- To set the motion detection zone, left click the mouse and then drag it to set the desired region. If the area is already blue (armed), dragging the mouse sets the cells clear (disarmed). If the area is already clear (disarmed), dragging the mouse sets the cells armed (blue).
- After setting the zone, exit and return to the Detect zone setup screen, by right clicking the mouse.
- Set the **Sensitivity** level 1-6, where 6 is the most sensitive. The default is 3.
- Select the **Test** button. A screen appears as in Figure 2-29. The system only displays the motion detect status of the blue area. The red flashing area shows motion has been detected in this area.

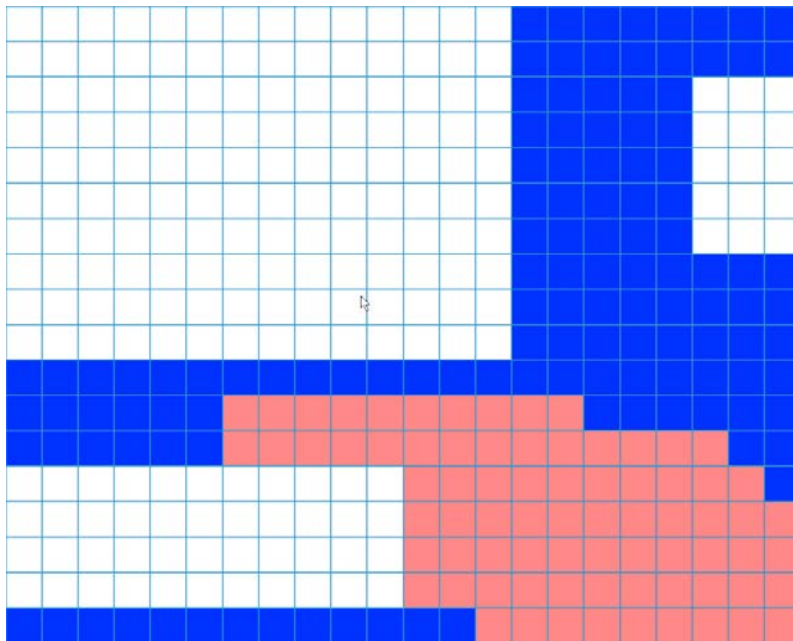

Figure 2-29

- In the **Period** area, select the **Setup** button. The Setup dialog opens for setting the motion detection period.

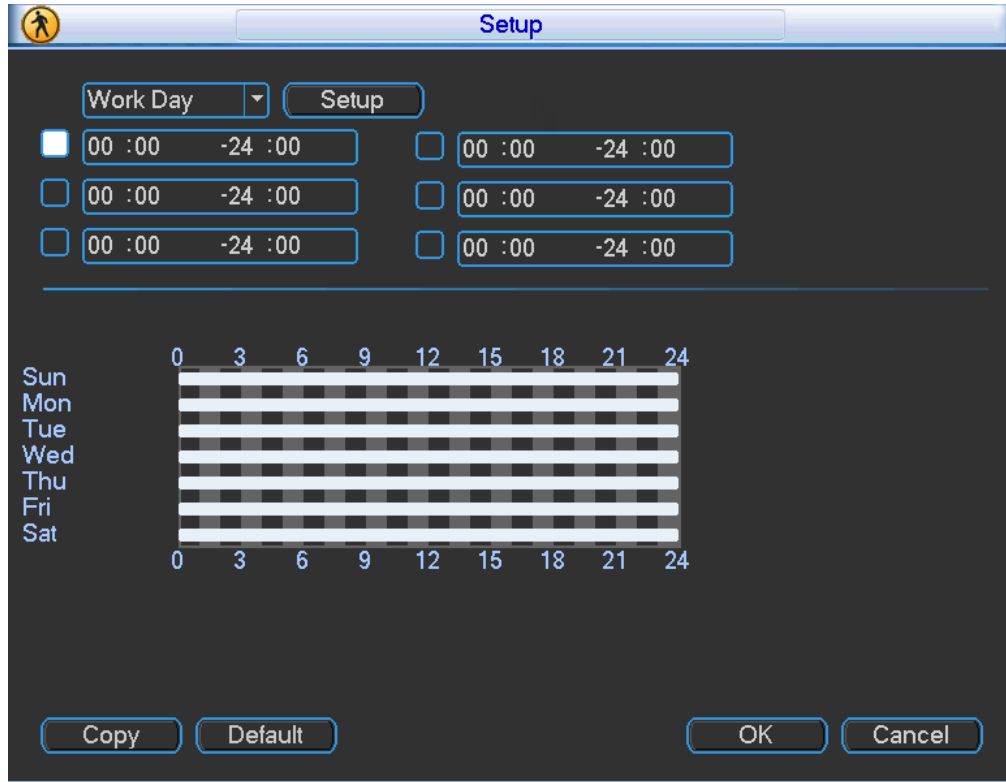

Figure 2-30

11. Select **Work Day** from the drop down list.
12. Select the **Setup** button. The Setup dialog appears.
13. Enable the working and free (non-business) days.

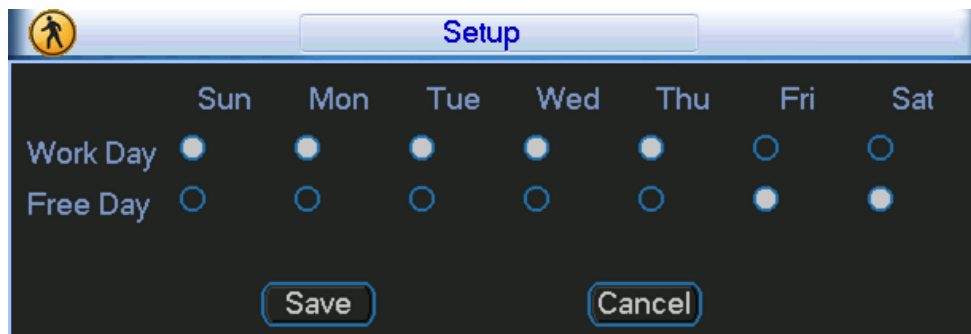



Figure 2-31

14. Select **Save** to return to the Setup screen (Figure 2-30). Six periods appear for you to set for each day.
15. Select the box to the left of a time period to enable it.
16. Set the start and end times for each motion detect period.
17. When finished, select **OK** to return to the Detect screen.

18. Select the desired alarm types: Alarm Out, Show Message, Record Channel, Tour, Snapshot, Buzzer, Alarm Upload, or Send Email (as described in section 2.6.1 **Detect Setup** on page 26).
19. Select the **Save** button to enact the current setup.
The Motion Detect icon  appears on the live video screen if the current channel has the motion detect alarm enabled.

2.6.2 Video Loss

This function informs you when no video signal is detected.

To set up a Video Loss event:

1. Open the Motion Detect screen by selecting *Main Menu > Setting > Detect*. The Detect screen opens.
2. In the Event Type area, select the drop-down menu and select **Video Loss**.

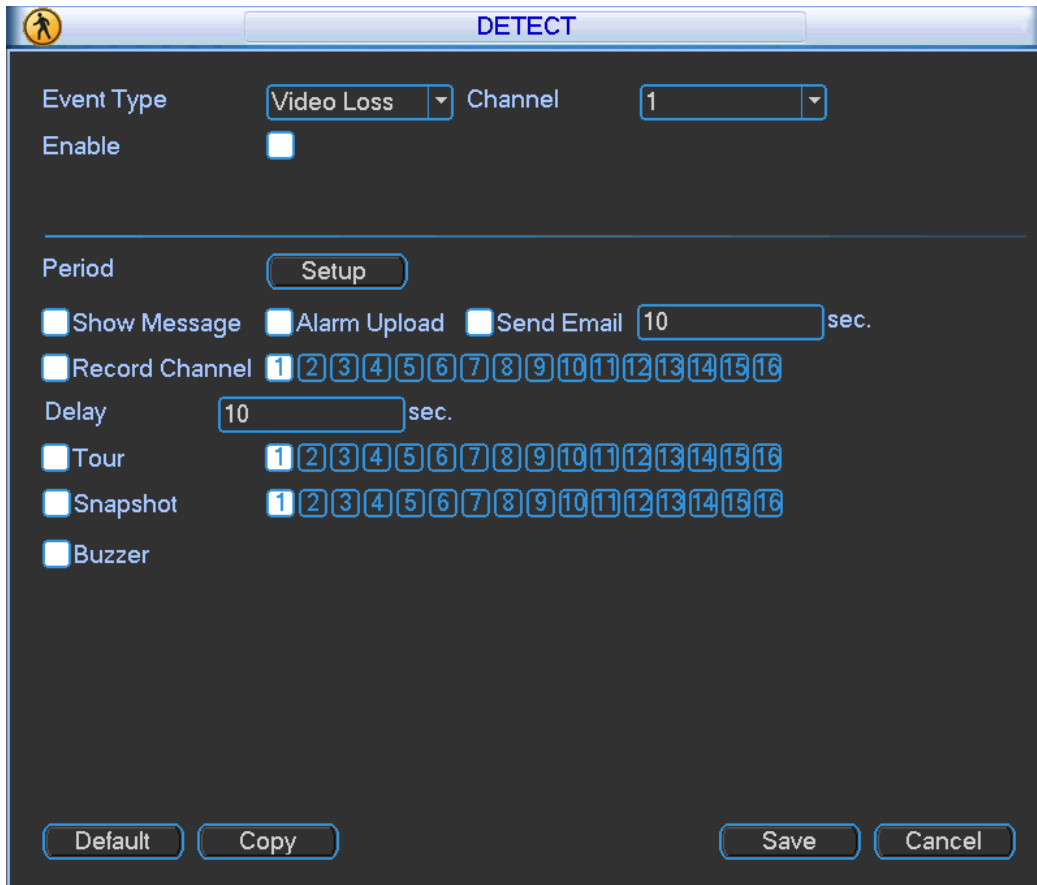

The screenshot shows the 'DETECT' configuration window. At the top, there is a 'DETECT' title bar. Below it, the 'Event Type' is set to 'Video Loss' and 'Channel' is set to '1'. The 'Enable' checkbox is currently unchecked. A 'Period' section contains a 'Setup' button. Underneath, there are several options with checkboxes: 'Show Message', 'Alarm Upload', and 'Send Email' (with a '10' second delay field); 'Record Channel' (checked) with a delay field set to '1' and a numeric keypad (1-16); 'Delay' set to '10' seconds; 'Tour', 'Snapshot', and 'Buzzer' (all unchecked) with numeric keypad (1-16) fields. At the bottom, there are four buttons: 'Default', 'Copy', 'Save', and 'Cancel'.

Figure 2-32

3. In the **Channel** area, select the channel you want to set up from the drop-down list.
4. Check the **Enable** checkbox to enable the Video Loss feature for this channel.

- In the **Period** area, select the **Setup** button. The Setup dialog opens for setting the time period during which the Video Loss will be a trigger event.



Figure 2-33

- Select **Work Day** from the drop down list.
- Select the **Setup** button. The Setup dialog appears.
- Enable the working and free (non-business) days.

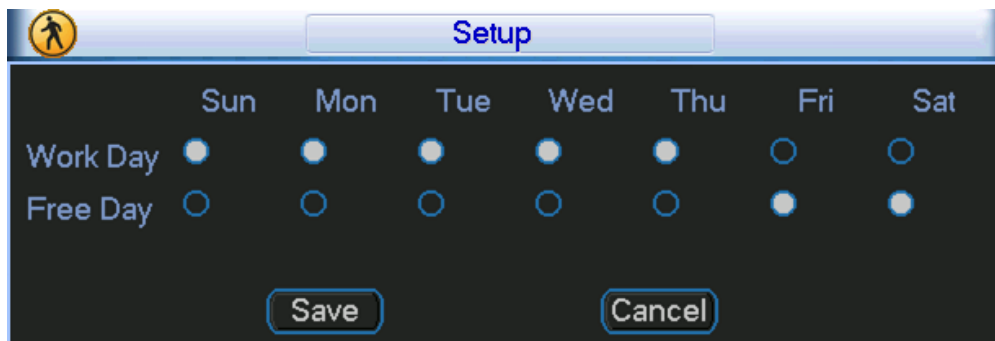



Figure 2-34

- Select **Save** to return to the Setup screen (Figure 2-30). Six periods appear for you to set for each day.
- Select the box to the left of a time period to enable it.

11. Set the start and end times for each motion detect period.
12. When finished, select **OK** to return to the Detect screen.
13. Select the desired alarm types: Alarm Out, Show Message, Record Channel, Tour, Snapshot, Buzzer, Alarm Upload, or Send Email (as described in section **2.6.1 Detect Setup** on page 26).
14. Select the **Save** button to enact the current setup.
The Video Loss icon  appears on the live video screen if the current channel has the Video Loss alarm enabled.

Note:

- There is no Detection Region, Sensitivity or Anti-dither setup for Video Loss.
- Video Loss is only enabled during the time period set. It is disabled for Motion Detection and Camera Masking.

2.6.3 Camera Masking

The Camera Masking feature alerts you when someone maliciously masks the lens, or the output video is in monochrome due to a change in ambient light.

To set up a Camera Masking event:

1. Open the Motion Detect screen by selecting *Main Menu > Setting > Detect*. The Detect screen opens.
2. In the Event Type area, select the drop-down menu and select **Camera Masking**.

The screenshot shows a configuration window titled "DETECT". At the top left is a person icon. The window contains the following elements:

- Event Type:** A dropdown menu showing "Camera Maski".
- Channel:** A dropdown menu showing "1".
- Enable:** An unchecked checkbox.
- Period:** A button labeled "Setup".
- Notification Options:** Three checkboxes: "Show Message", "Alarm Upload", and "Send Email". The "Send Email" checkbox is checked, and next to it is an input field containing "10" followed by "sec.".
- Record Channel:** A row of 16 numbered buttons (1-16). The button "1" is highlighted.
- Delay:** An input field containing "10" followed by "sec.".
- Tour:** A row of 16 numbered buttons (1-16). The button "1" is highlighted.
- Snapshot:** A row of 16 numbered buttons (1-16). The button "1" is highlighted.
- Buzzer:** An unchecked checkbox.
- Buttons:** At the bottom, there are four buttons: "Default", "Copy", "Save", and "Cancel".

Figure 2-35

3. In the **Channel** area, select the channel you want to set up from the drop-down list.
4. Check the **Enable** checkbox to enable the Camera Masking feature for this channel.
5. In the **Period** area, select the **Setup** button. The Setup dialog opens for setting the time period during which Camera Masking will be a trigger event.



Figure 2-36

6. Select **Work Day** from the drop down list.
7. Select the **Setup** button. The Setup dialog appears.
8. Enable the working and free (non-business) days.

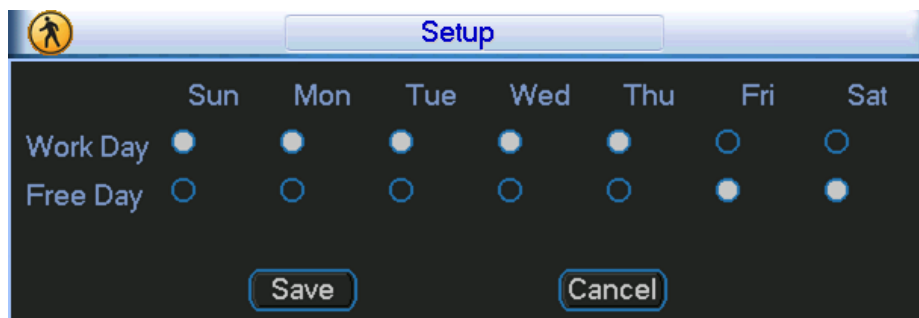

Figure 2-37

9. Select **Save** to return to the Setup screen (Figure 2-30). Six periods appear for you to set for each day.
10. Select the box to the left of a time period to enable it.
11. Set the start and end times for each motion detect period.
12. When finished, select **OK** to return to the Detect screen.
13. Select the desired alarm types: Alarm Out, Show Message, Record Channel, Tour, Snapshot, Buzzer, Alarm Upload, or Send Email (as described section **2.6.1 Detect Setup** on page 26).
14. Select the **Save** button to enact the current setup.

Note:

- There is no Detection Region or Anti-dither setup for Camera Masking.
- Camera Masking is only enabled during the time period set. It is disabled for Motion Detection and Video Loss.

2.7 Backup

The DVR supports USB device backup and network download backup. This section describes USB backup. USB backup devices include USB burners, flash drives, SD cards and portable hard disk drives (HDD). Refer to **4 Web** for the network download backup operation.

To setup USB Backup:

1. Click the **Backup** button on the Main Menu. The Backup screen appears, showing all the backup device information.

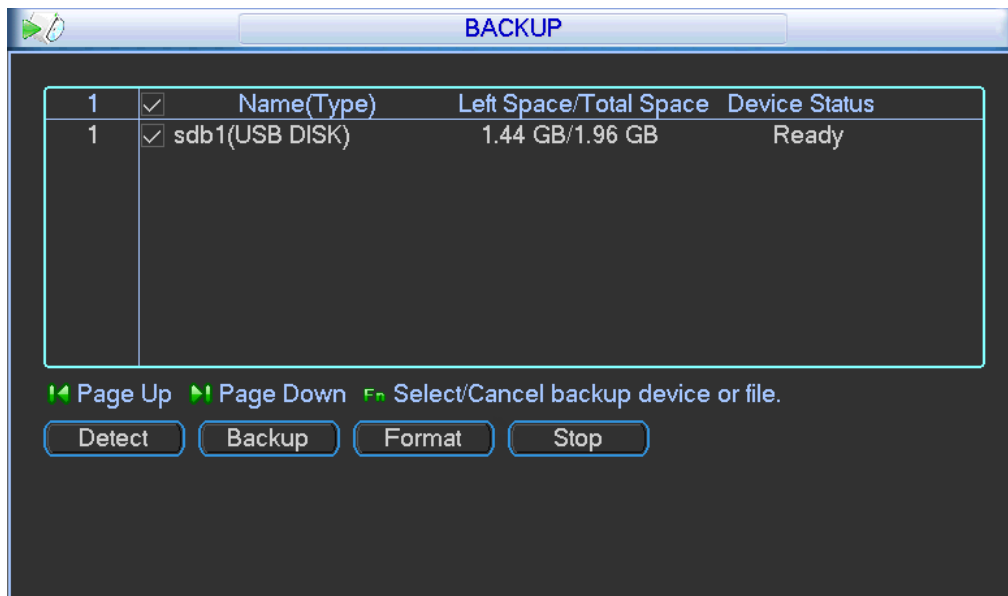

Figure 2-38

2. Click the **Detect** button. You can view the device name and total / free space available for each backup device that is connected.
3. Select the device you want to backup.

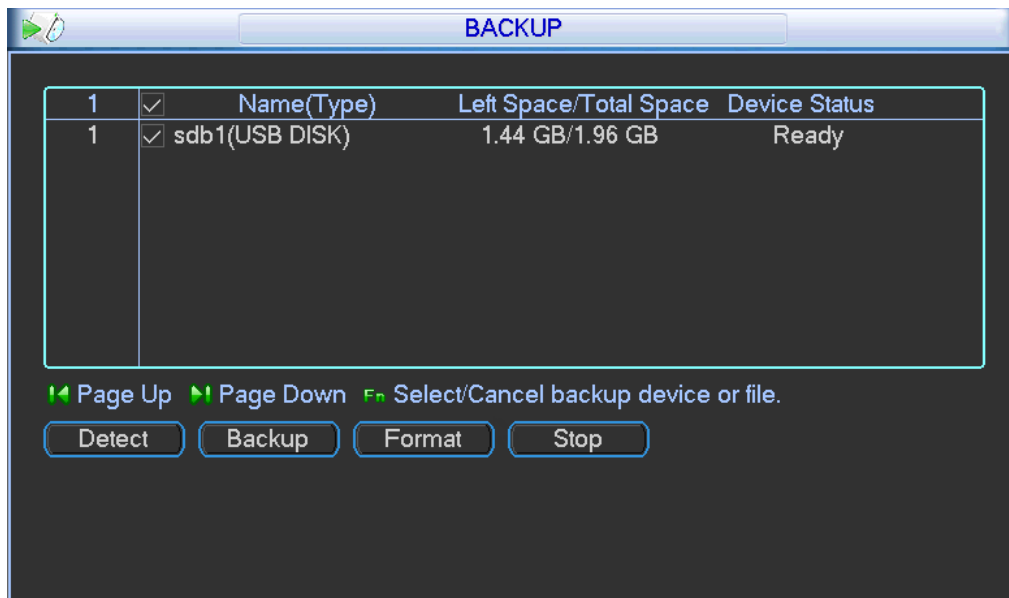

Figure 2-39

4. Click the **Backup** button. The following screen appears.

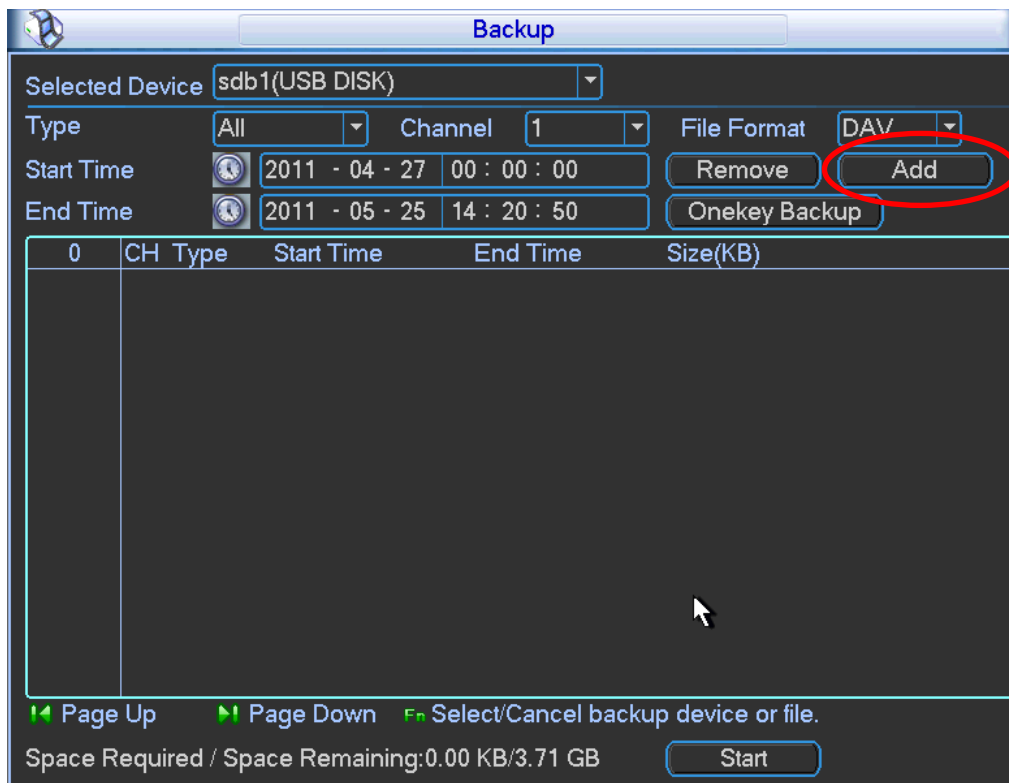

Figure 2-40

5. Set the channel, file start time and end time.

- Click the **Add** button. The system begins a search, and then lists all matching files. The system automatically calculates the capacity needed and remained.

The system can only backup files with a √ before the channel name.

- Click the **Backup** button to backup the selected files. A progress bar appears for your reference.

When the system completes backup, a dialog box appears displaying successful backup.

- Click the **Backup** button to begin burning. At the same time, the Backup button becomes a Stop button. You can view the remaining time and process bar at the left bottom.
 - File format.** Click the file format. Select between two options: DAV/ASF.
 - Picture backup.** Set the corresponding time, channel and then select PIC from the dropdown list. See Figure 2-4 1. Click the **Add** button and then select the pictures. Click the **Start** button to copy the specified pictures to the selected portable devices.

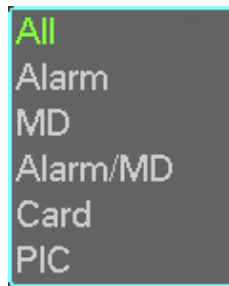

Figure 2-41

- One key backup.** This process includes three steps: search, select all and start the backup. This allows you to skip the above three steps and copy all the searched files directly.

The file name format is: <Channel number> + <Record type> + <Time>. In the file name, the YDM format is Y+M+D+H+M+S. The file extension name is **.dav**.

TIP: During the backup process, you can click ESC to exit the current screen to perform other operations. The system will not terminate backup process.

Note: When you click the Stop button during the burn process, the stop function activates immediately. For example, if there are ten files when you click stop, the system just backs up five files. The system only saves the previous 5 files in the device.

3 Menu Operations

This section describes in detail all menu options available with the DVR5 1xxC Series DVR.

3.1 Menu Tree

The DVR5 1xxC Series DVR menu tree is shown below.

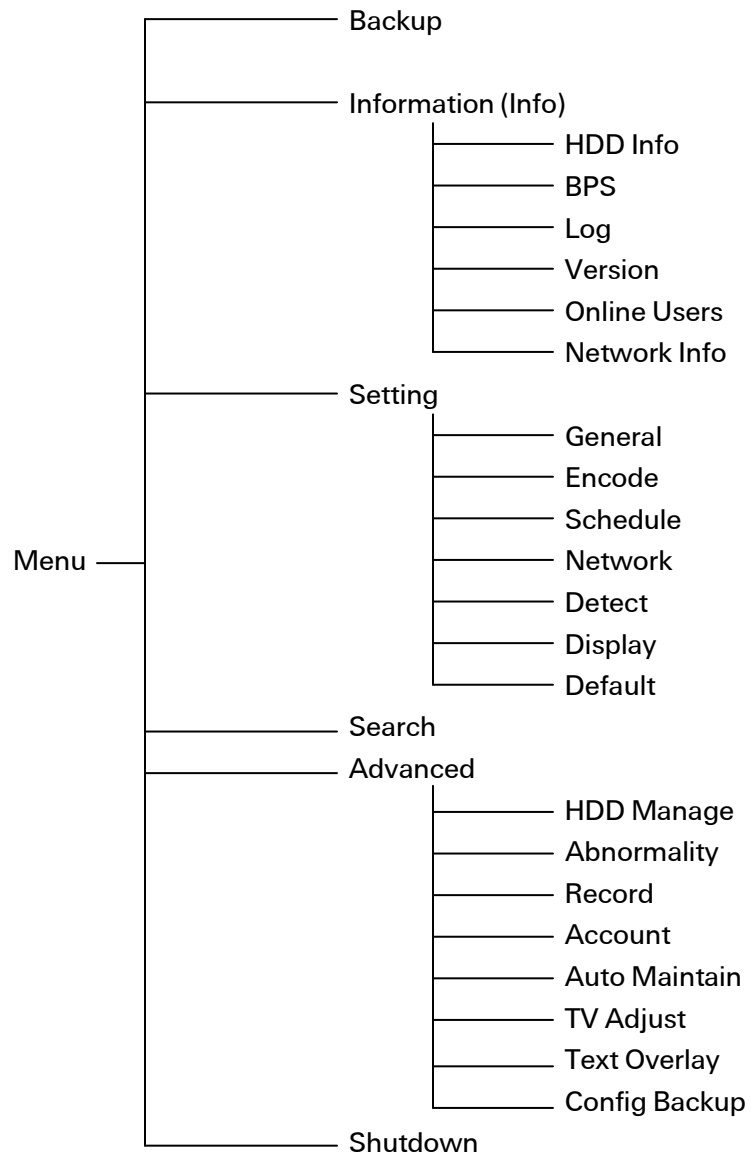

3.2 Main Menu

Open the Main Menu by right-clicking and selecting Main Menu from the context menu. There are six icons: Search, Info, Setting, Advanced, Backup and Shutdown. Click an icon to enter the corresponding sub menu.

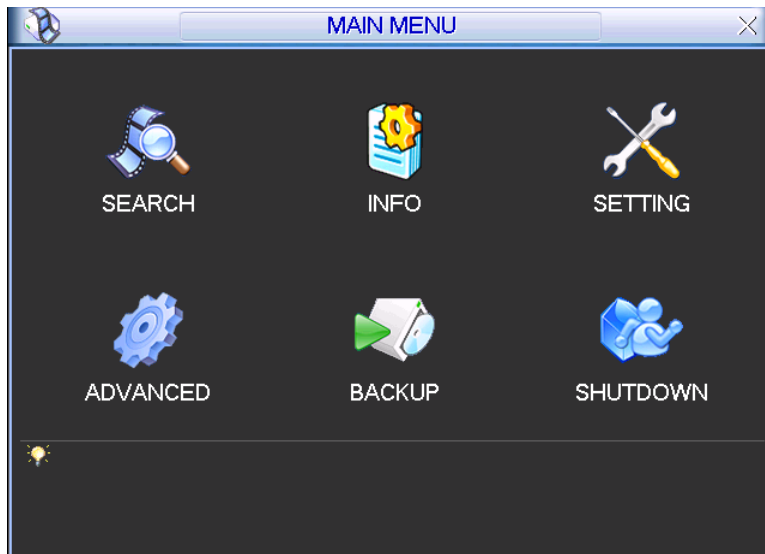

Figure 3-1

3.3 Setting

In the Main Menu, click the Setting icon. The Setting screen opens.

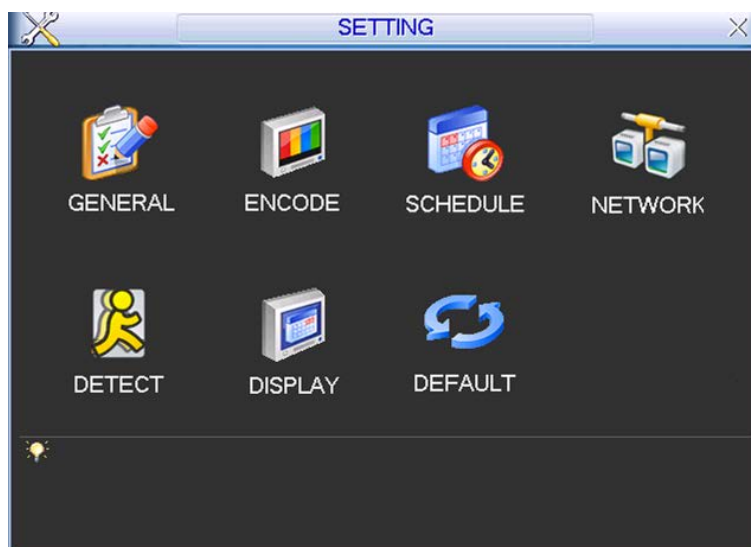

Figure 3-2

3.3.1 General

General setting includes the following items. See Figure 3-3. After completing all settings, click the **OK** button. The system reverts to the previous menu.

The screenshot shows a 'GENERAL' settings window with the following fields and options:

- System Time:** 2013 - 01 - 05 23 : 28 : 46, with a 'Save' button.
- Basic Settings:**
 - Date Format: YYYY MM DD (dropdown)
 - DST: [] Set (checkbox and button)
 - Date Separator: - (dropdown)
 - Time Format: 24-HOUR (dropdown)
- Device Settings:**
 - Language: ENGLISH (dropdown)
 - Video Standard: NTSC (dropdown)
 - Device No.: 8 (text input)
 - Device ID: DVR (text input)
 - HDD Full: Overwrite (dropdown)
 - Pack Duration: 60 min. (text input)
 - Realtime Play: 5 min. (text input)
- Other Settings:**
 - Holiday: [] Setup (checkbox and button)
 - Navigation Bar: [] Setup (checkbox and button)
 - Startup Wizard: [] Setup (checkbox and button)
 - Mouse Property: Setup (button)
 - Auto Logout: 10 min. (text input)

Buttons at the bottom: Default, OK, Cancel.

Figure 3-3

System Time

This section is for setting the system time.

Date Format

There are three types: YYYY-MM-DD: MM-DD-YYYYY or DD-MM-YYYY.

Date Separator

There are three denotations to separate date: dot, beeline and solidus.

DST

This section is for setting DST time and date. Enable the DST function and then click the **Set** button. The DST dialog opens, as shown in Figure 3-4. Here you can set start time and end time by setting corresponding week setup. In Figure 3-4, enable date button. The dialog changes to the one shown in Figure 3-5. Here you can set start time and end time by setting the corresponding date setup.

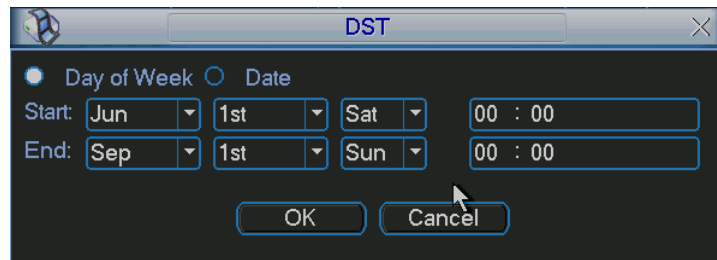

Figure 3-4

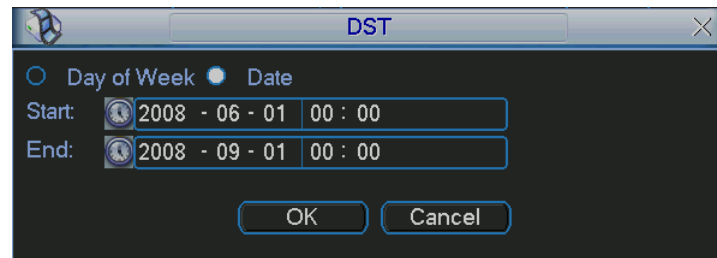

Figure 3-5

Time Format

There are two types: 24-hour mode or 12-hour mode.

Language

The system supports various languages: Chinese (simplified), Chinese (Traditional), English, Italian, Japanese, French and Spanish. All languages listed here are optional.

Video Standard

There are two formats: NTSC and PAL.

Device No.

Input a corresponding device number.

Device ID

Input a corresponding device name here.

HDD Full

In this section you can select the working mode when the hard drive is full. There are two options: stop recording or rewrite. If the current working HDD is overwritten or the current HDD is full while the next HDD is not empty, then the system stops recording, If the current HDD is full and the next HDD is not empty, then the system overwrites the previous files.

Pack Duration

This section is for specifying the duration of the recording. The value ranges from 1 to 120 minutes. Default value is 60 minutes.

Real-time Playback

This sets the playback time you can view in the instant playback feature. (See 2.2 Live Viewing on page 7). The value ranges from 5 to 60 minutes.

Holiday

Click the box to enable the use of holiday settings.

Holiday Setup

Click the **Setup** button to display the dialog for selecting the dates you want to include as holidays. Refer to section **2.5 Schedule** on page 20 for instructions on how to set recording schedules for holidays you have set up.

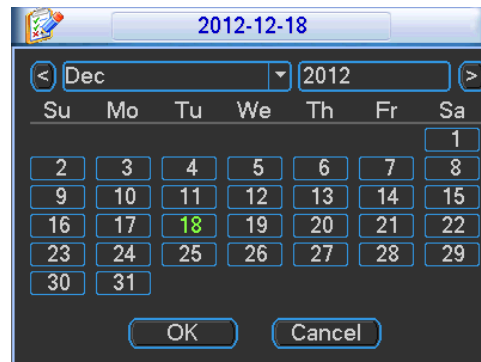

Figure 3-6

Note: There is no year setup on the Holiday setup. For example, if you set May 26th, 2014 as a holiday, then the date of May 26th will be set as a holiday every year.

Navigation Bar

Enable this to display the navigation bar on the screen.

Startup Wizard

If this box is checked, the system opens with the Startup Wizard when the device boots up the next time. Otherwise, the system opens with the System Login dialog.

Mouse Property

Click the Mouse Property **Setup** button to open the Mouse Setup dialog. Set the Double-click Speed by dragging the slider. Click the **Default** button to restore the default setup.

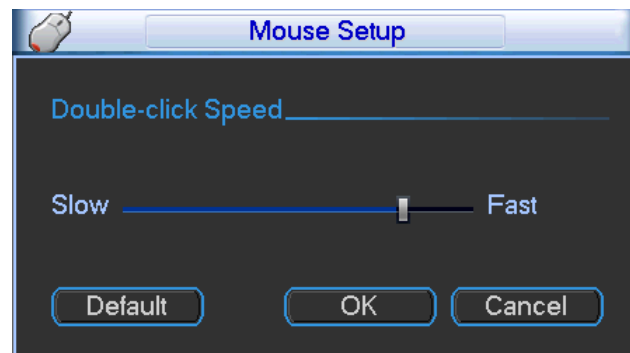

Figure 3-7

Auto Logout

This enables you to set auto logout interval once login user remains inactive for a specified time. The value ranges from 0 to 60 minutes.

Note:

- Because system time is very important, do not modify the time unless necessary.
- Stop the record operation before making a time modification.

3.3.2 Encode

Video compression settings are made in the Encode dialog. Options include the following items. See Figure 3-8. Highlight the box  to select the corresponding function.

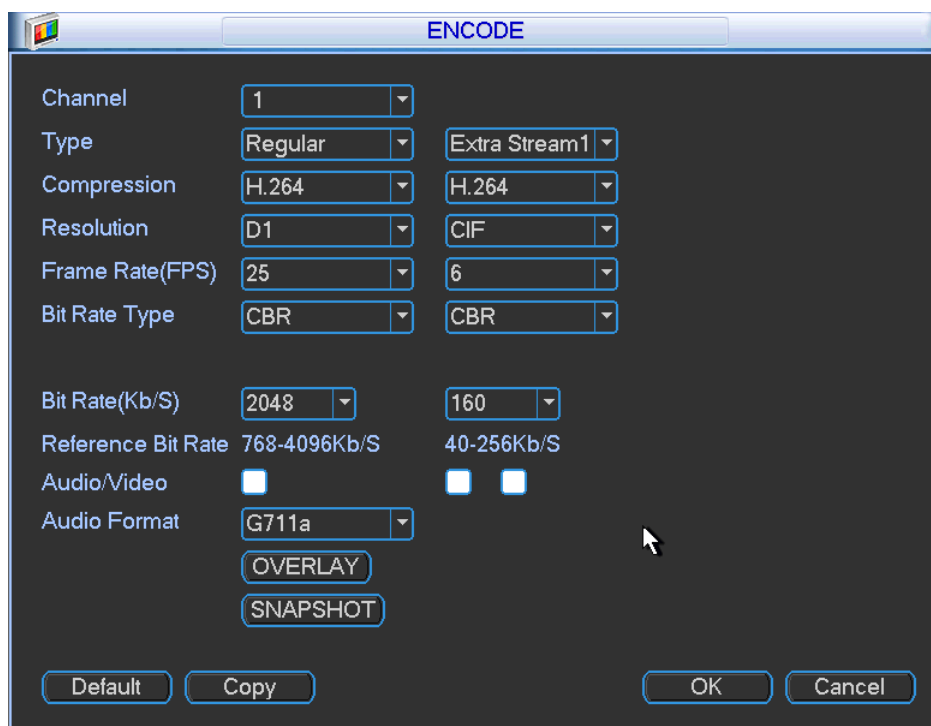

Figure 3-8

Channel

Select the channel you want.

Type

Select from the dropdown list. There are two options: regular/motion detect. You can set the various encode parameters for different recording types.

Compression

The system supports H.264.

Resolution

The system supports various resolutions, you can select from the dropdown list. The main stream supports D1/HD1/2CIF/CIF/QCIF and the extra stream supports CIF/QCIF. Note the option may vary due to different series.

Frame Rate (FPS)

This ranges from 1f/s to 25f/s in NTSC mode and 1f/s to 30f/s in PAL mode.

Bit Rate Type

The system supports two types: Constant Bit Rate (CBR) and Variable Bit Rate (VBR). In VBR mode, you can set video quality.

Quality

There are six levels ranging from 1 to 6. The sixth level has the highest image quality.

Audio/ Video

Use this checkbox to enable or disable the video/audio.

Note: *ADT does not support Audio functions at this time.*

Overlay

Click the Overlay button to open the Overlay dialog, which determines whether the following items are displayed on the monitor screen.

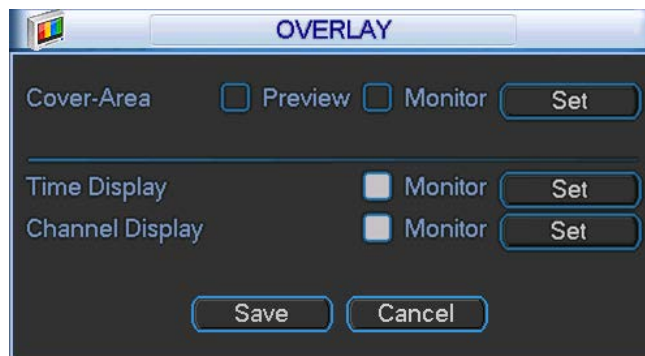

Figure 3-9

- **Cover Area (Privacy Mask).** This section is for setting the Privacy Mask. In the dialog, use your mouse to set the desired mask size and location. In single channel video mode, the system supports a maximum of 4 zones in one channel.
- **Preview/Monitor.** Privacy mask has two types: Preview and Monitor. Preview means the Privacy Mask zone cannot be viewed by user when in live video mode. Monitor means the Privacy Mask zone cannot be view by the user when in playback mode.
- **Time Display.** Select whether the time is displayed during playback. Click the **Set** button and then drag the title to the corresponding position in the screen.
- **Channel Display.** Select whether the system displays the channel number during playback. Click the **Set** button and then drag the title to the corresponding position in the screen.

Snapshot

Click the **Snapshot** button to set snapshot mode, picture size, quality and frequency.

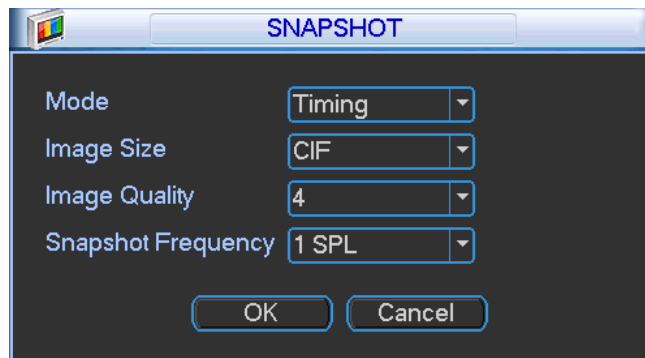

Figure 3-10

- **Mode:** There are two modes: Timing (Schedule) and activation. If you set timing mode, you need to set the snapshot frequency. If you set activation snapshot, you need to go to the Detect interface (*Main Menu > Setting > Detect*) to set snapshot activation operation.
- **Image Size:** Set the snapshot picture size.
- **Image Quality:** Set the snapshot quality. The value ranges from 1 to 6.
- **Snapshot Frequency:** Set the timing (schedule) snapshot interval. The value ranges from 1-7 picture(s) per second.

Copy. After you complete the setup, you can click **Copy** button to copy the current setup to other channel(s). A dialog opens as shown in Figure 3-11. Check the number to select specific channel(s) or else check the **All** box. The current channel number is grayed out. Click the **OK** button in Figure 3-9 and Figure 3-8 respectively to complete the setup.

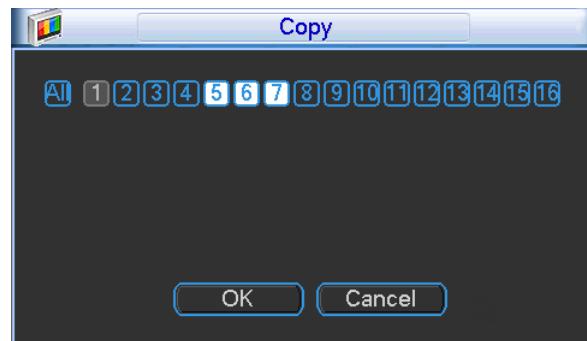

Figure 3-11

Note: Once you check the **All** box, you set same encode setup for all channels. The Audio/Video enable box, Overlay button and Copy button disappear.

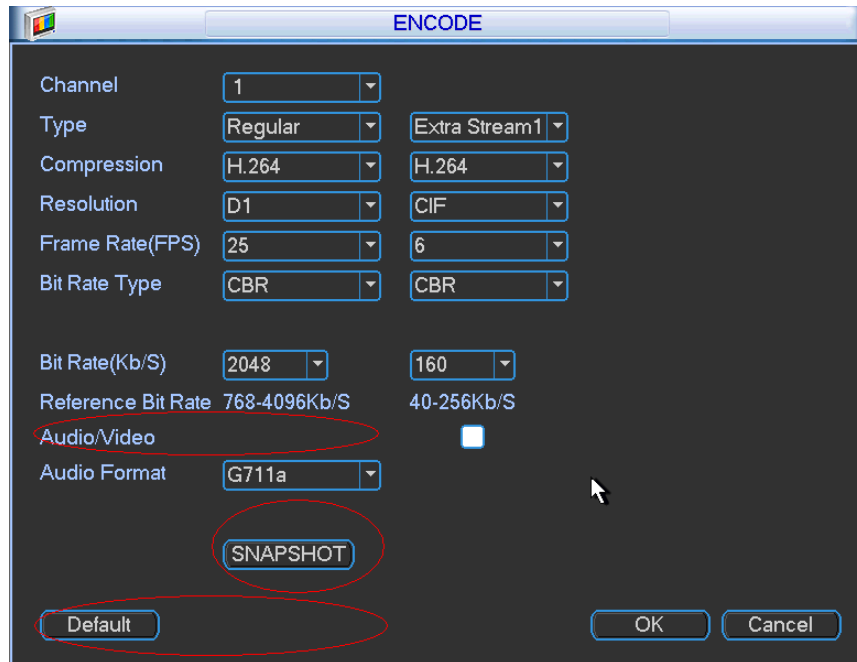

Figure 3-12

3.3.3 Schedule

Refer to section 2.5 Schedule on page 20.

3.3.4 Network

This section is for inputting the network information. The single network adapter dialog is shown in Figure 3-13 and the dual network adapter dialog (for most C Series products) is shown in Figure 3-14.

The screenshot shows a 'NETWORK' configuration window with the following fields and values:

- IP Version: IPv4
- IP Address: 10 . 15 . 5 . 223
- Subnet Mask: 255 . 255 . 0 . 0
- Gateway: 10 . 15 . 0 . 1
- TCP Port: 37777
- HTTP Port: 80
- UDP Port: 37778
- RTSP Port: 554
- Max Connection: 20
- MTU: 1500
- Preferred DNS: 8 . 8 . 8 . 8
- Alternate DNS: 8 . 8 . 4 . 4
- LAN Download:

Buttons at the bottom: Default, Save, Cancel.

Figure 3-13

The screenshot shows a 'NETWORK' configuration window for a dual network adapter with the following fields and values:

- Net Mode: Multi-address
- Default Ethernet Port: Ethernet1
- Network Device Name: Ethernet1
- IP Version: IPv4
- IP Address: 20 . 2 . 3 . 48
- Subnet Mask: 255 . 255 . 255 . 0
- Gateway: 20 . 2 . 3 . 1
- TCP Port: 37777
- HTTP Port: 80
- UDP Port: 37778
- RTSP Port: 554
- Max Connection: 20
- MTU: 1500
- Preferred DNS: 8 . 8 . 8 . 8
- Alternate DNS: 8 . 8 . 4 . 4
- LAN Download:

Buttons at the bottom: Default, Save, Cancel.

Figure 3-14

IP Version

There are two options: IPv4 and IPv6. At this time, the system only supports IPv4.

MAC address

The LAN host has a unique MAC address. This item is read-only.

IP Address

In this section you can use the up/down buttons (▲▼) or input the corresponding numbers to input the IP address. Then you can set the corresponding subnet mask and the default gateway.

Subnet Prefix

The input value ranges from 0 to 128 and is used to mark a specified network MAC address. Usually it includes a multiple-level organization.

Default Gateway

In this section you can input the default gateway. The IP address and the Default Gateway must be in the same IP section. That is to say, the specified length of the subnet prefix must have the same string.

DHCP

This section is for auto searching the IP. When you enable the DHCP function, you cannot modify the IP/Subnet mask /Gateway. These values are from the DHCP function. If you have not enabled the DHCP function, then the IP, Subnet Mask and Gateway are displayed as zero. You must disable DHCP function to view current IP information. When PPPoE is operating, you cannot modify the IP, Subnet Mask or Gateway.

IMPORTANT: For the following four ports (TCP, UDP, HTTP and RTSP), the system must be rebooted after you have changed and saved any setup parameter. Make sure that these four port values do not conflict with one another.

TCP Port

Default value is 37777. You can change if necessary.

UDP Port

Default value is 37778. You can change if necessary.

HTTP Port

Default value is 80.

RTSP Port

Default value is 554.

Max Connection

The system supports a maximum of 128 users.

MTU

Displays the Maximum Transmission Unit (MTU) value of the network adapter. The value ranges from 1280-7200 bytes. The default setup is 1500 bytes.

MTU modification can affect current network service and may result in a reboot of the network adapter. When you change the MTU setup, a pop up dialog box appears for you to confirm the setup. Click the OK button to confirm the reboot or click Cancel to terminate the modification. Before the modification, verify that the MTU of the DVR is the same as or lower than the MTU of the gateway. In this way, you can reduce packets and enhance network transmission efficiency.

The following MTU values are for reference only.

- **1500:** This is the Ethernet information packet maximum value and the default. It is the typical setup when there is no PPPoE or VPN. It is also the default setup of some routers, switches and network adapters.
- **1492:** Recommended value for PPPoE.
- **1468:** Recommended value for DHCP.

Preferred DNS Server

DNS server IP address.

Alternate DNS Server

DNS server alternate address.

Transfer Mode

Select the priority between fluency/video qualities.

LAN Download

The system can process the downloaded data first if you enable this function. The download speed is 1.5X or 2.0X of the normal speed.

Dual Network Adapters Mode

Multiple-address mode: eth0 and eth1 operate separately. You can use the services such as HTTP, RTP service via eth0 or the eth1 usually you must set one default card (default setup is eth0) to request the auto network service from the device-end such as DHCP, email, FTP, etc. In multiple-address mode, system network status is shown as offline once one card is offline.

Network fault-tolerance: In this mode, device uses bond0 to communicate with the external devices. You can focus on one host IP address. At the same time, you must set one master card. Usually there is only one running card (master card). The system can enable alternate card when the master card is malfunction. The system is shown as offline once these two cards are both offline. Note these two cards must be in the same LAN.

Load balance: In this mode, device uses bond0 to communicate with the external device. The eth0 and eth1 are both working now and bearing the network load. Their network load are general the same. The system is shown as offline once these two cards are both offline. Note these two cards must be in the same LAN.

After completing the setup, click the **Save** button. The system returns to the previous menu.

3.3.4.1 Network Setting

The Network Setting dialog is shown in Figure 3-15. Check the box to enable corresponding function and then double click the item to open its setup dialog.

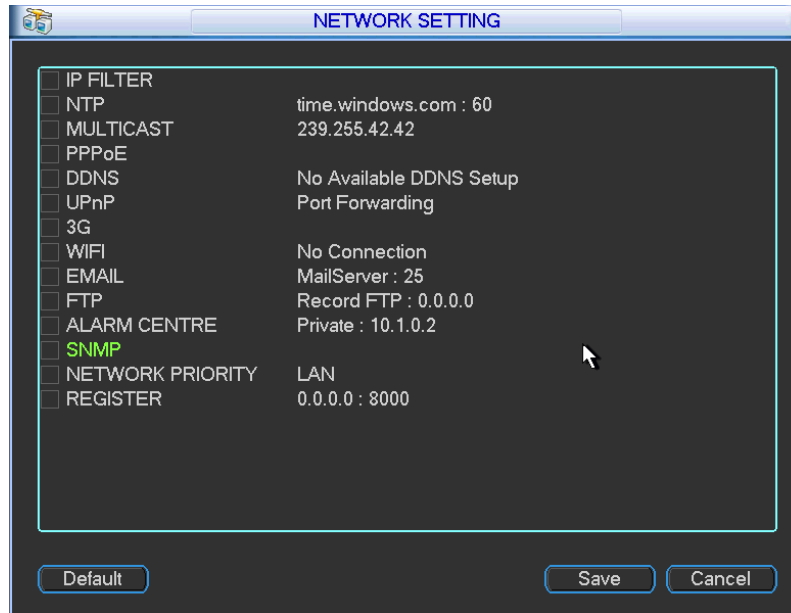

Figure 3-15

3.3.4.2 IP Filter

The IP filter dialog is shown in Figure 3-16. You can add IP in the following list. The list supports a maximum 64 IP addresses. The system only supports IPv4 at this time.

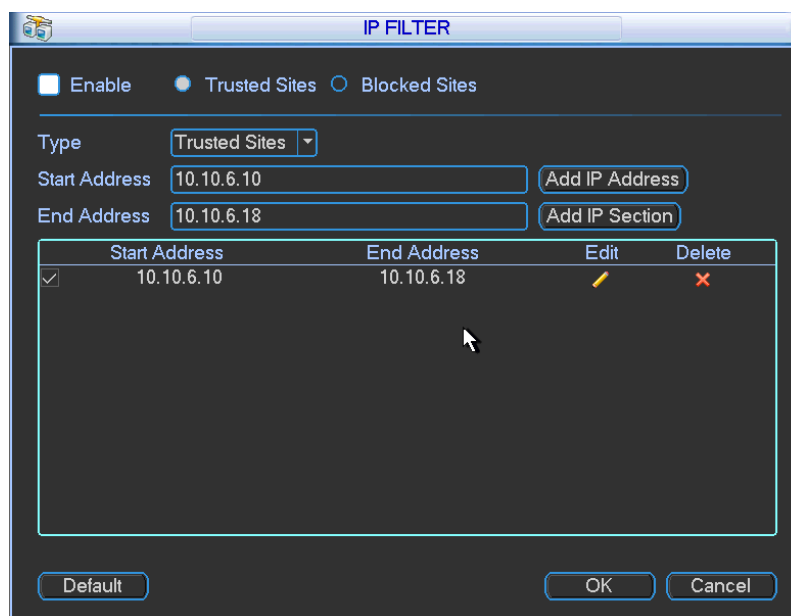

Figure 3-16

After you enabled trusted sites function, only the IP listed below can access current DVR. If you enable blocked sites function, the following listed IP addresses cannot access current DVR.

Enable

Highlight this box to enable the trusted site function and blocked sites function. You cannot see these two modes if the **Enable** button is grayed out.

Type

You can select trusted site and blacklist from the dropdown list. You can view the IP address on the following column.

Start Address/End Address

Select one type from the dropdown list, you can input IP address in the start address and end address. Click **Add IP Address** or **Add IP Section** to add.

- Newly added IP addresses are enabled by default. Remove the $\sqrt{\quad}$ before the item to remove it from the list.
- The system supports a maximum of 64 items.
- The system automatically removes space if there is any space before or after the newly added IP address.
- The system only checks the start address if you add an IP address. The system checks the start address and end address if you add an IP section. The end address must be larger than the start address.
- The system may check whether the newly added IP address exists. The system does not add if the input IP address does not exist.

Delete

Click to remove the specified item.

Edit

Click to edit the start address and end address. See Figure 3-17. The system checks the IP address validity after the edit operation.

Default

Click to restore default setup. In this case, the trusted sites and blocked sites are both removed.

Note:

- If you enabled trusted sites, only the IP in the trusted sites list can access the device.
- If you enabled blocked sites, the IP in the blocked sites cannot access the device.
- The system supports add MAC address.

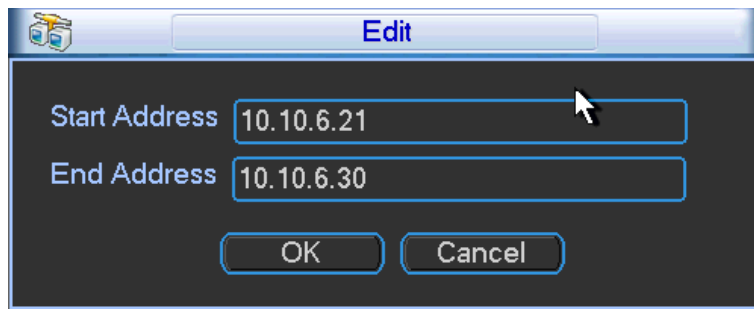

Figure 3-17

3.3.4.3 NTP Setup

You must install an SNTP server (such as Absolute Time Server) in your PC first. In Windows XP OS, you can use command `net start w32time` to boot up the NTP service.

NTP setup dialog is shown in Figure 3-18.

- **Host IP.** Input your PC address.
- **Port.** This DVR series supports TCP transmission only. Port default value is 123.
- **Update interval.** Minimum value is 1, in minutes; maximum value is 65535
- **Time zone.** Select your corresponding time zone here.
- **Manual update.** Enables you to synchronize the time with the server manually.

Following is a reference table for time zone setup.

City /Region Name	Time Zone
London	GMT+0
Berlin	GMT+1
Cairo	GMT+2
Moscow	GMT+3
New Deli	GMT+5
Bangkok	GMT+7
Beijing (Hong Kong)	GMT+8
Tokyo	GMT+9
Sydney	GMT+10
Hawaii	GMT-10
Alaska	GMT-9
Pacific Time (P.T)	GMT-8
American Mountain Time (M.T)	GMT-7
American Central Time (C.T)	GMT-6
American Eastern Time(E.T)	GMT-5
Atlantic Time	GMT-4
Brazil	GMT-3
Middle Atlantic Time	GMT-2

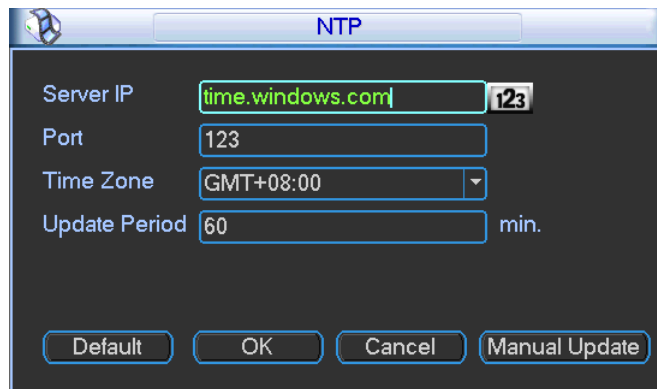

Figure 3-18

3.3.4.4 Multicast Setup

Multicast is a transmission mode for data packets. Multicast sends IP datagrams to a group of receivers in a single transmission. When there are multiple hosts to receive the same data packet, multicast is the best option to reduce the bandwidth and the CPU load. The source host can send out just one data packet. This function also depends on the relationship of the group member and the group.

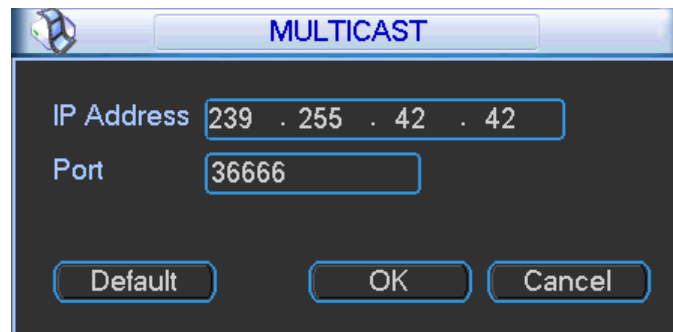

Figure 3-19

Refer to the following list for detailed information.

- IP multicast group address
 - 224.0.0.0-239.255.255.255
 - "D" address space
 - The higher four-bit of the first byte="1 1 1 0"
- Reserved local multicast group address
 - 224.0.0.0-224.0.0.255
 - TTL=1 When sending out telegraph
 - For example:
 - 224.0.0.1 All systems in the sub-net
 - 224.0.0.2 All routers in the sub-net
 - 224.0.0.4 DVMRP router

- 224.0.0.5 OSPF router
- 224.0.0.13 PIMv2 router
- Administrative scoped addressees
 - 239.0.0.0–239.255.255.255
 - Private address space
 - Like the single broadcast address of RFC1918
 - Cannot be used in Internet transmission
 - Used for a multicast broadcast in limited space

Except the above mentioned reserved addresses, you can use other addresses.

For example:

- Multicast IP: 235.8.8.36
- Multicast PORT: 3666.

After you have logged onto the Web, the Web can automatically get a multicast address and add it to the multicast groups. You can enable real-time monitor function to view the view.

Note that the Multicast function applies to special series only.

3.3.4.5 PPPoE

The PPPoE (Point to Point Protocol over Ethernet) dialog is shown in Figure 3-20.

To set up the PPPoE feature:

1. Input the User Name and Password you received from your Internet service provider (ISP).
2. Click the **OK** button.
3. Reboot the system to activate your configuration.

After rebooting, the DVR connects to Internet automatically. The IP in the PPPoE is the DVR dynamic value. You can access this IP to access the unit.

Figure 3-20

3.3.4.6 DDNS Setup

The DDNS setup dialog appears below in Figure 3-21.

Requirements: You must have a PC with a fixed IP and DDNS software running. In other words, this PC is a DNS (domain name server).

To set up the DDNS feature:

1. In network DDNS, select DDNS type and highlight enable item.
2. Input the PPPoE name you get from your IPS and server IP (PC with DDNS).
3. Click the **OK** button. The system prompts you to reboot to activate the setup.
4. After rebooting, open a browser window and enter:
`http://(DDNS server IP)/(virtual directory name)/webtest.htm`
 (e.g.: `http://10.6.2.85/DVR_DDNS/webtest.htm.`)
5. Open the DDNS Server web search page.

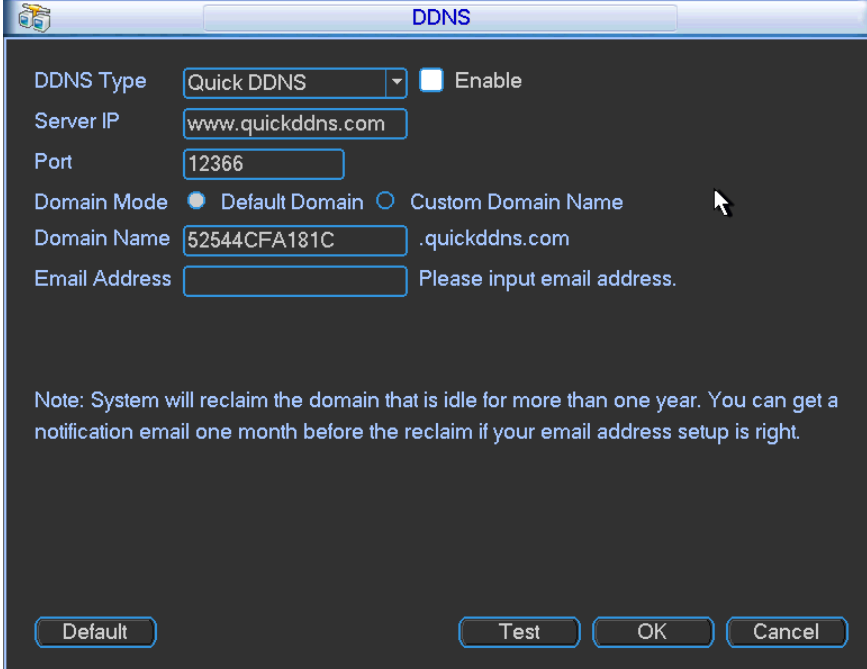

Figure 3-21

Note that NNDS type includes: CN99 DDNS, NO-IP DDNS, Quick DDNS and DynDNS DDNS. You can setup all DDNS clients to be valid at the same time.

The Quick DDNS function works with a special DDNS server and special professional surveillance software (ADT VideoView).

Quick DDNS and Client End Introduction

1. Background Introduction

The device IP is not fixed if you use ADSL to log into the network. The DDNS function enables you to access the DVR via the registered domain name. Besides the general DDNS, the Quick DDNS works with the device from the manufacturer so that it can add the extension function.

2. Function Introduction

The quick DDNS client has the same function as other DDNS clients. It initiates the bonding of the domain name and the IP address. At this time, the current DDNS server is for our own devices only. You must refresh the bonding relationship of the domain and the IP regularly. There is no user name, password or the ID registration on the server. At the same time, each device has a default domain name (generated by MAC address) for your option. You can also use a customized valid domain name (not registered).

3. Operation

Before you use Quick DDNS, you must enable this service and set the proper server address, port value and domain name.

- Server address: www.quickddns.com
- Port number: 80
- Domain name: There are two modes: Default domain name and customized domain name.

You can use the default domain name registration or a customized domain name (using your self-defined domain name.) After successful registration, you can use the domain name to login instead of the device IP. The user name is optional; you can input your commonly-used email address.

IMPORTANT:

- Do not register frequently. The interval between two registrations must be more than 60 seconds.
- The system may take back the domain name that is idle for one year. You can get a notification email before the cancel operation if your email address setup is OK.

3.3.4.7 UPNP

The UPNP protocol establishes a mapping relationship between the LAN and the WAN. Input the router IP address in the LAN, as shown in Figure 3-14. Double click the UPNP item in Figure 3-15. The following dialog opens.

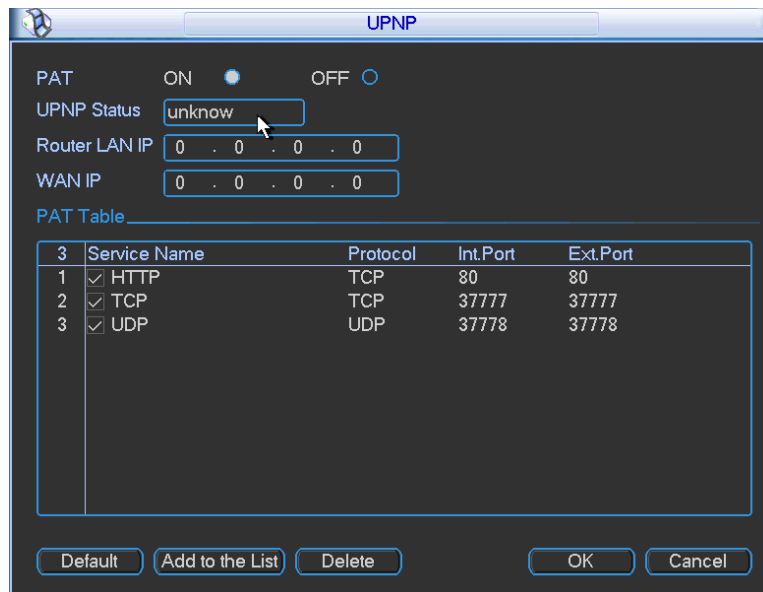

Figure 3-22

UPNP On/Off

Turn the UPNP function ON or OFF.

Status

When UPNP is offline, this field displays “Unknown”. When UPNP is online, it shows “Success”.

Router LAN IP

This is the router IP in the LAN.

WAN IP

This is the router IP in the WAN.

Port Mapping List

The port mapping list here is the one to one relationship with the router’s port mapping setting.

Enable

If checked, this indicates that port mapping is enabled for this port.

List

Displays the following items:

- **Service Name.** Defined by user.
- **Protocol.** Protocol type
- **Internal Port.** Port that has been mapped in the router.
- **External Port.** Port that has been mapped locally.

Default

Click to restore the UPNP default port setting of the HTTP, TCP and UDP.

Add to the List

Click to add the mapping relationship.

Delete

Click to remove one mapping item.

Double click an item to change the corresponding mapping information. See Figure 3-23.

IMPORTANT: When you are setting the router external port, use 1024-5000. Do not use ports 1-255 and system ports 256-1023 to avoid conflict. For the TCP and UDP, make sure the internal port and external port are the same to ensure the proper data transmission.

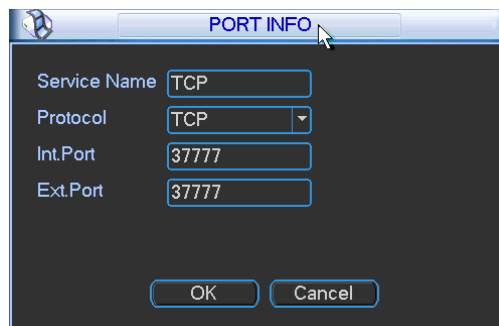

Figure 3-23

3.3.4.8 3G

3G is not supported by ADT at this time.

3.3.4.9 WIFI

WIFI is not supported by ADT at this time.

3.3.4.10 Email

The email dialog is shown below in Figure 3-24.

The screenshot shows an 'EMAIL' configuration window with the following fields and values:

- SMTP Server: MailServer
- Port: 25
- Anonymous:
- User Name: [Empty]
- Password: [Empty]
- Receiver: [Empty]
- Sender: [Empty]
- Title: DVR ALERT
- Attachment:
- Encrypt Type: NONE
- Event Interval: 120 sec.
- Health Enable:
- Interval: 60 min.

Buttons at the bottom: Default, OK, Cancel, Test.

Figure 3-24

SMTP Server

Enter your email SMTP server IP.

Port

Enter the corresponding port value.

User Name

Enter the user name to login to the sender's email box.

Password

Enter the corresponding password.

Receiver

Enter the receiver's email address. The system supports a maximum of 3 email boxes and automatically filters out duplicate addresses.

Sender

Enter the sender's email address.

Title

Enter the email subject line (32 alphanumeric characters max).

SSL Enable

Check to enable SSL encryption.

Event Interval

Enter the delay time in seconds following the alarm event before another email is sent out. The interval ranges from 0 to 3600 seconds, where 0 means there is no delay and the email is sent immediately.

Health Enable

Check the box to enable this function, which enables the system to send out a test email for testing the connection.

Interval

Enter the delay time in seconds following the test alarm before another email is sent out. The interval ranges from 0 to 3600 seconds, where 0 means there is no delay and the email is sent immediately.

Test

Click the **Test** button test the email connection.

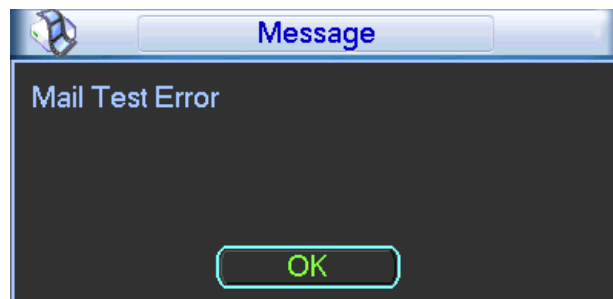

Figure 3-25

Note that the system will not send out the email immediately when the alarm occurs. When the Motion Detection or the Abnormality event activates the email, the system sends out the email according to the interval setting specified here. This function is very useful when there are too many emails activated by Abnormality events, resulting in a heavy load for the email server.

3.3.4.11 FTP

You must download or buy an FTP service tool (such as Ser-U FTP SERVER) to establish the FTP service. Install the Ser-U FTP SERVER first. (*Start > All Programs > Serv-U FTP Server > Serv-U Administrator*). Then set the user password and FTP folder. Note that you must grant write rights to the FTP upload user.

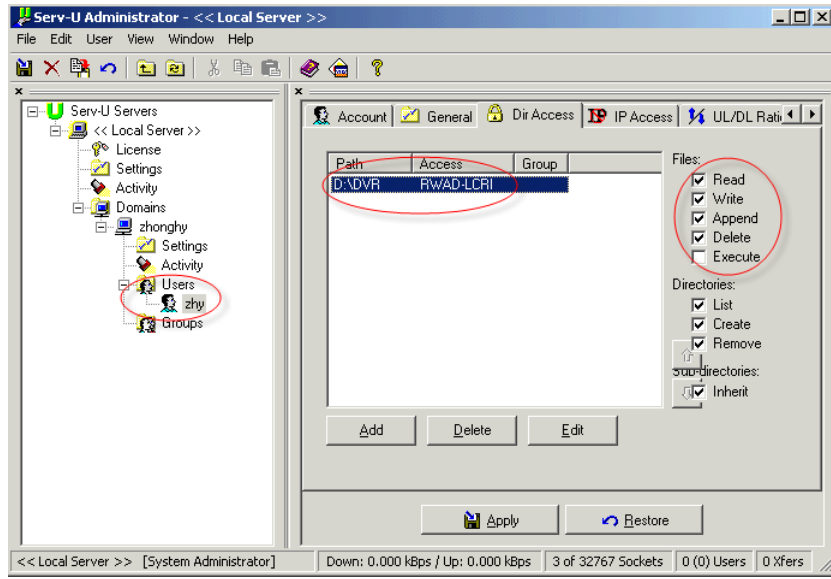

Figure 3-26

You can use a PC or FTP login tool to test that it is setup properly. For example, you can login user ZHY to [FTP://10.10.7.7](ftp://10.10.7.7) and then test it to modify or delete the folder.



Figure 3-27

The system also supports upload multiple DVRs to one FTP server. You can create multiple folders under this FTP. Select FTP and then double click it. The following dialog appears.

Figure 3-28

To use the FTP feature:

1. Highlight the Enable box to activate the FTP function.
2. Input the FTP server address, port and remote directory. When a remote directory is not available, the system automatically creates folders according to the IP, time and channel.
3. Enter the User Name and Password as the account information for you to login the FTP.
4. Set upload file length, picture upload interval, upload file channel, time and type.
 - File length is upload file length. When this value is larger than the actual file length, the system will upload the whole file. When this value here is smaller than the actual file length, the system only uploads the set length and automatically ignores the left section. When the interval value is 0, the system uploads all corresponding files.
 - At the same time, you can set two periods and three recording files for different channels.
5. Click the **Test** button. The corresponding dialog box appears to show that the FTP connection is OK. See Figure 3-29.

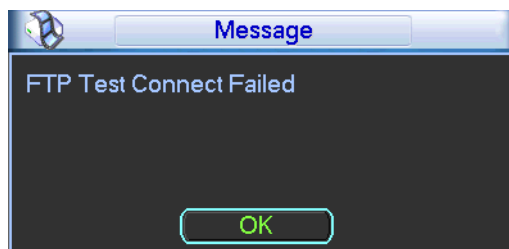

Figure 3-29

3.3.4.12 Alarm Centre

Alarm Centre is not supported by ADT at this time.

3.3.4.13 SNMP

SNMP is an abbreviation of Simple Network Management Protocol. It provides the basic network management framework of the network management system. SNMP is widely used in many environments, network devices, software and systems.

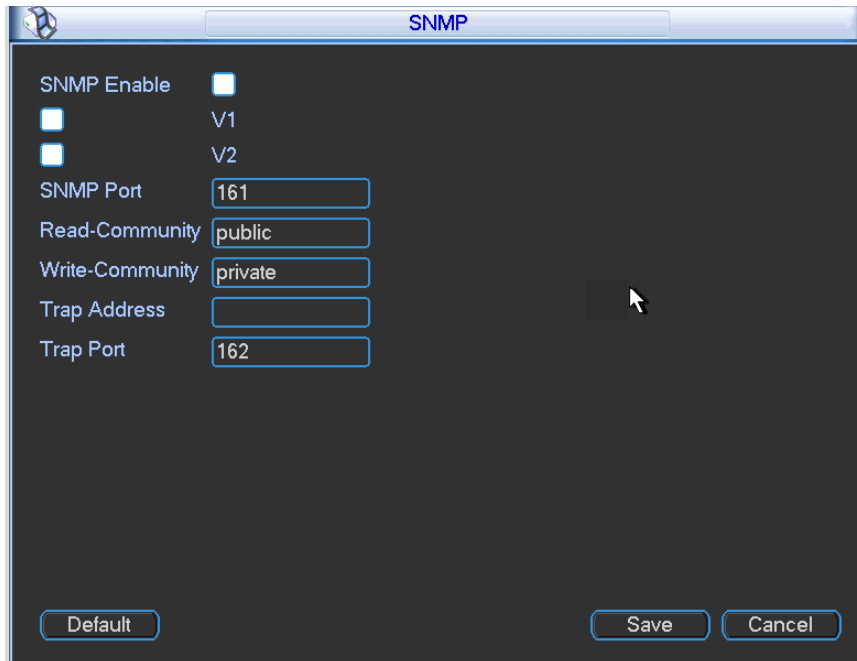

Figure 3-30

Enable the SNMP function. Use the corresponding software tool (MIB Builder and MG-SOFT MIB Browser). You will need two MIB files: BASE-SNMP-MIB, DVR-SNMP-MIB) to connect to the device. You can get the device's corresponding configuration information after a successful connection.

To configure SNMP:

1. In Figure 3-30 above, check the box to enable the SNMP function. Input the IP address of the PC than is running the software in the Trap address. You can use the default setup for the rest of the items.
2. Compile the above mentioned two MIB file via the software MIB Builder.
3. Run MG-SOFT MIB Browser to load the file from the previous step to the software.
4. Input the device IP you want to manage in the MG-SOFT MIB Browser. Set the corresponding version for future reference.
5. Open the tree list on the MG-SOFT MIB Browser to get the device configuration. Here you can see how many video channels and application versions the device has.

Note: A port conflict occurs when the SNMP port and Trap port are the same.

3.3.4.14 Network Priority

This dialog is for setting network priority. The default setup is *PPPoE>LAN*. You can change the priority if necessary. WIFI and 3G are not supported by ADT.

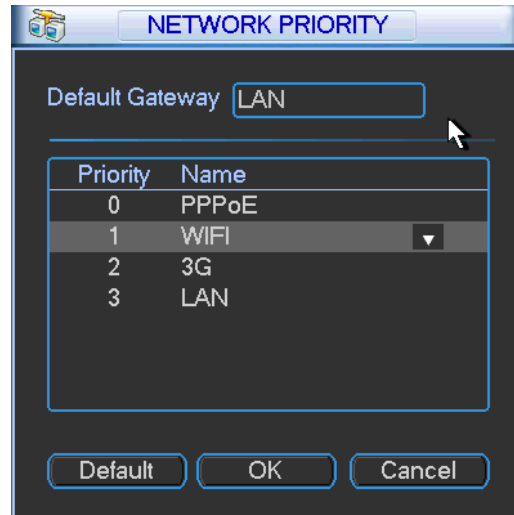

Figure 3-31

Default Gateway. This area displays the current default gateway. It displays PPPoE if the PPPoE dial is successful.

Priority. This value ranges from 0 to 3. The highest priority is 0.

Name. This area displays the network name. Use ▲/▼ to move the priority of the current item up/down.

Note:

- PPPoE always has the highest priority.
- WIFI and 3G are not supported by ADT at this time.

3.3.4.15 Auto Register

This function enables the device to automatically register to the proxy you have specified. In this way you can use the client end to access the DVR via the proxy. In the network service, the device supports a server address of IPv4 protocol.

To use the Auto Register function:

1. Set the proxy server address, port and sub-device name at the device end.
2. Enable the Auto Register function. The device automatically registers to the proxy server.

IMPORTANT: Do not input a network default port such as the TCP port number.

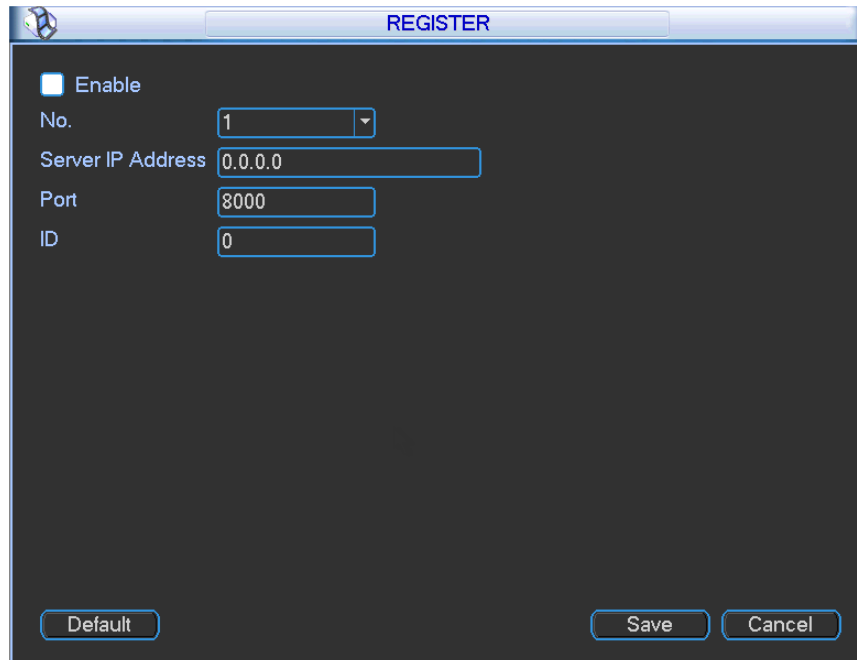

Figure 3-32

3. The proxy server software is developed from the SDK. Open the software and input the global setup. Make sure the auto connection port here is the same as the port you set in the previous step.
4. Now add the device. Do not input default port number such as the TCP port in the mapping port number. The device ID used here must be the same as the ID you input prior.
5. Click the **Add** button to complete the setup.
6. Boot up the proxy server.

When the network status is **Y**, the registration is successful. You can view the proxy server when the device is online.

IMPORTANT: The server IP address can also be the domain but you must register a domain name before you run the proxy device server.

3.3.5 Detect

Refer to section **2.6 Detect** on page 26.

3.3.6 Display

The Display Setup screen is shown in the following figure.

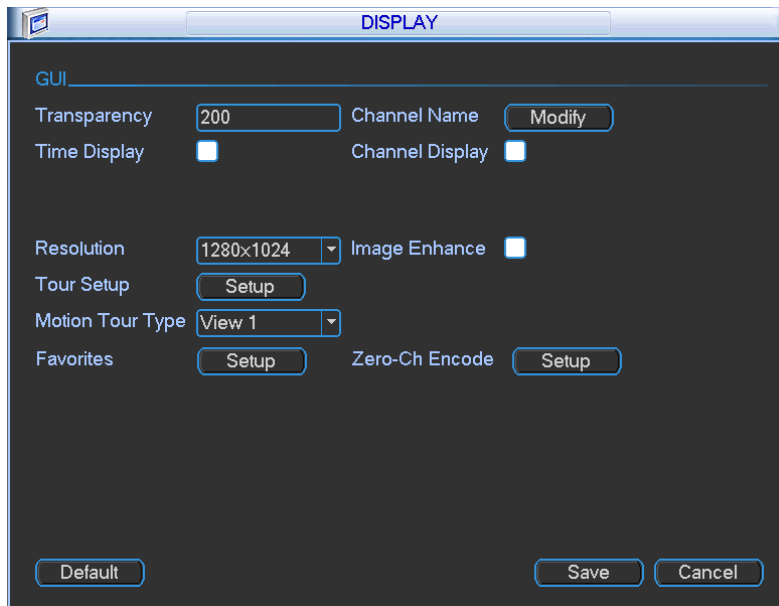

Figure 3-33

Transparency

Enter a value for GUI's transparency over the viewing window, ranging from 128 to 255.

Channel Name

Modify the Channel Name in this field. The system supports a maximum of 25 characters (The value may vary in different series). Note that all your modifications here only apply to the DVR local end. You must open the web or client end to refresh the Channel Name.

Time Display

Select to display the time during playback.

Channel Display

Select to display the channel name during playback.

Resolution

There are four options: 1920 x1080, 1280 x1024 (default), 1280 x720 and 1024 x768. You must reboot to activate the new setup.

Image Enhance

Check the box to optimize the live video image quality.

Motion Tour Type

Select from the dropdown the motion tour combination set up in the Tour Setup screen below.

Tour Setup

Here you can activate the Tour function, which presents an alternating display (much like a slideshow) of the channel(s) you have set to record when a motion detection event occurs. Click the **Setup** button to open the Tour Setup screen.

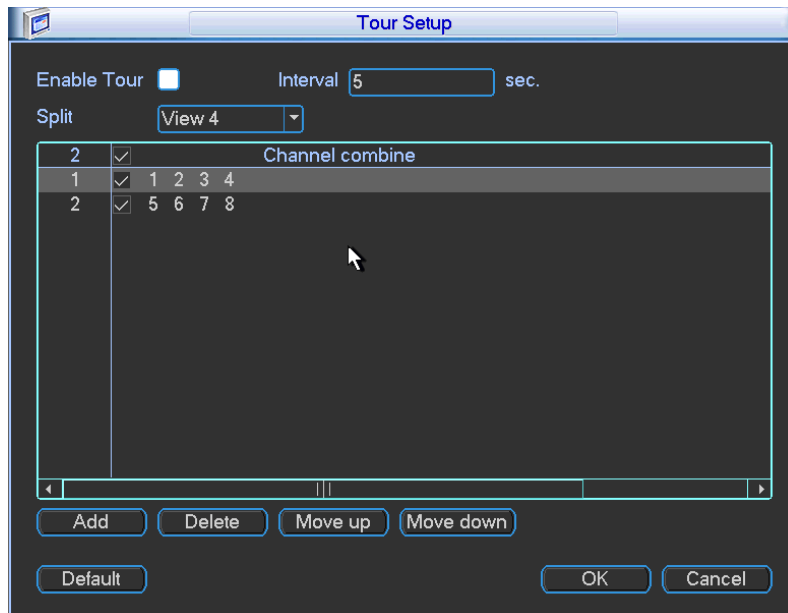

Figure 3-34

- **Enable Tour.** Check the box to enable this function.
- **Interval.** The system supports 1/4/8/9/16-window tour. Input the desired interval value here for the scheduled tour/motion detection tour. The value ranges from 5-120 seconds.
- **Split.** Select the window split mode from the dropdown list.
- **Channel Combination.** This area is for viewing channel names under current window split mode. You can add/delete channels here. Double click an item to edit the channel group. The system supports a maximum of 16 channels.
- **Add.** Under the specified window split mode, click to add a channel group.
- **Delete.** Click to remove the selected channel group.
- **Move up.** Click to move the currently selected channel up.
- **Move down.** Click to move the currently selected channel down.
- **Default.** Click to restore the default setup.

After completing the settings, click the **OK** button. The system returns to the previous menu.

Click the **Modify** button, to the right of the Channel Name. The Channel Name dialog opens, as shown in Figure 3-35. Note that all your modifications here apply to the local end only. You will need to refresh web or client end to get the latest Channel Name. The system supports a maximum of 25 characters for Channel Name.

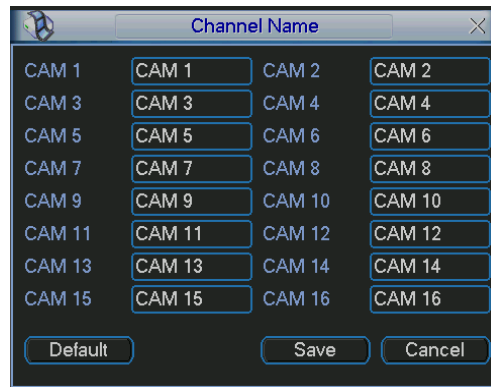

Figure 3-35

3.3.7 Default

Click the **Default** button. The Default dialog box opens. Check the box for the corresponding item that you want to restore to the default factory setup.

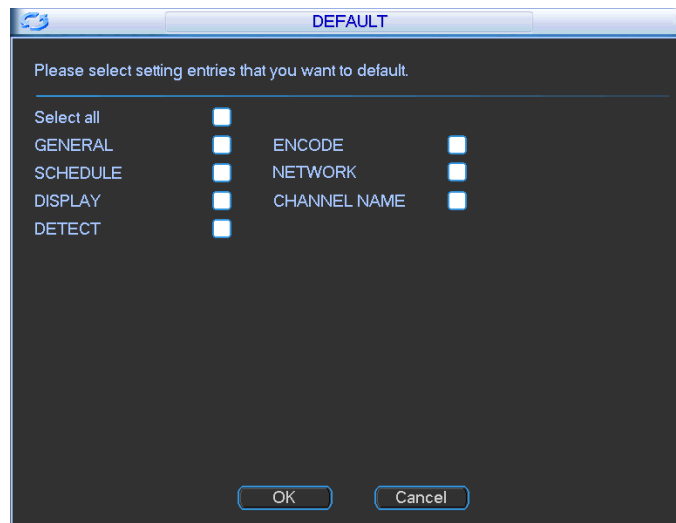

Figure 3-36

After completing the setup, click the **OK** button. The system reverts to the previous menu.

3.4 Search

Refer section **2.4 Search and Playback** on page 12.

3.5 Advanced

Click the **Advanced** icon in the main window. The Advanced screen appears. There are eight function keys: HDD Management, Abnormality, Manual Record, Account, Auto Maintenance, TV Adjust, Text Overlay and Config Backup.



Figure 3-37

3.5.1 HDD Management

The HDD Management section is used to view and edit settings for the hard disk drive. Click the **HD Manage** icon to open the HDD Manage screen.

Here you can view the current HDD type, status, capacity and record time:

- 0—HDD is working properly
- X—HDD error

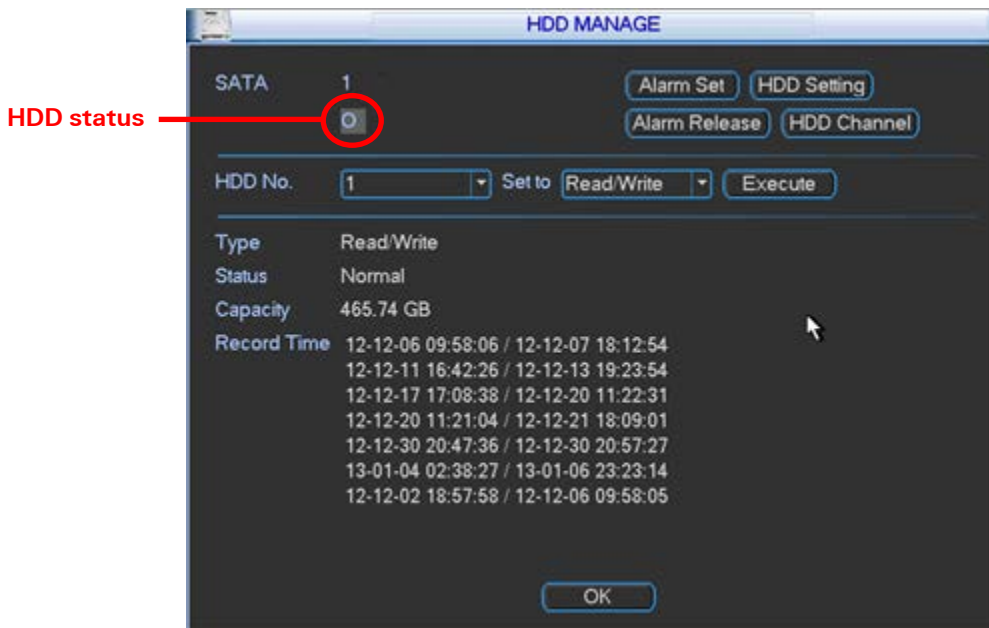

Figure 3-38

Note:

- Each channel's recordings can be stored in the specified HDD Group.
- Each HDD Group corresponds to several hard disks, while each hard disk is only included in only one HDD Group.
- Each channel corresponds with only one HDD Group, while one HDD Group can store recordings from several channels.
- The HDD Group is only available for read-write hard drives and self-defined disks. Other types of hard disks cannot be set as an HDD Group.
- The current software version can only set the HDD group operation for read-write HDDs.

3.5.1.1 HDD Setting

Click the **HDD Setting** button on the **HDD Manage** screen (see Figure 3-38). The **HDD Setting** screen appears.

HDD. Here you can view the hard disk size that the device can support. If there is a mark in the box in front of the number, the current position has a HDD installed.

HDD Group. This lists the HDD Group number of the current hard disk.

To set the HDD Group:

1. Check the box of the hard disk.
2. Select the corresponding HDD Group number
3. Click **Save**.

Note: Each HDD has its own group—the HDD group number corresponds with the HDD port. If you change the HDD, the corresponding HDD group may change.

3.5.1.2 Channel Settings

Click the button labeled **HDD Channel** at the top right corner of The HDD Manage dialog (Figure 3-38). The HDD Channel dialog appears.



Figure 3-39

Channel

This field displays the HDD channel number.

HDD Group

Use the dropdown to select a group number for the particular hard drive. HDD group has only two options: group 1 or group 2.

After selecting the HDD group number, click the **Save** button to complete the setup.

As an example, you may want to set odd channels 1–15 on the left of Figure to group 1 and assign even channels 2–16 to HDD group 2. In this setup, the recordings from channel 1 and channel 3 are both saved in the HDD for group 1 and the recordings from channel 2 and channel 4 are saved in the HDD of group 2.

IMPORTANT: After you change the HDD Group settings, the system will pack the recordings and then reboot.

Note: There is an easy way for you to test whether the recordings from the corresponding channel are being saved in the specified HDD. Remove the HDD and then check whether the channel can record. You are able to verify that the channel does not record and that you cannot search for the previous recording.

3.5.2 Abnormality

The Abnormality screen enables you to set how you would like to be notified when specified events occur. Click the **Abnormality** icon in the Advanced screen (See Figure 3-37 on page 71). The Abnormality screen appears.

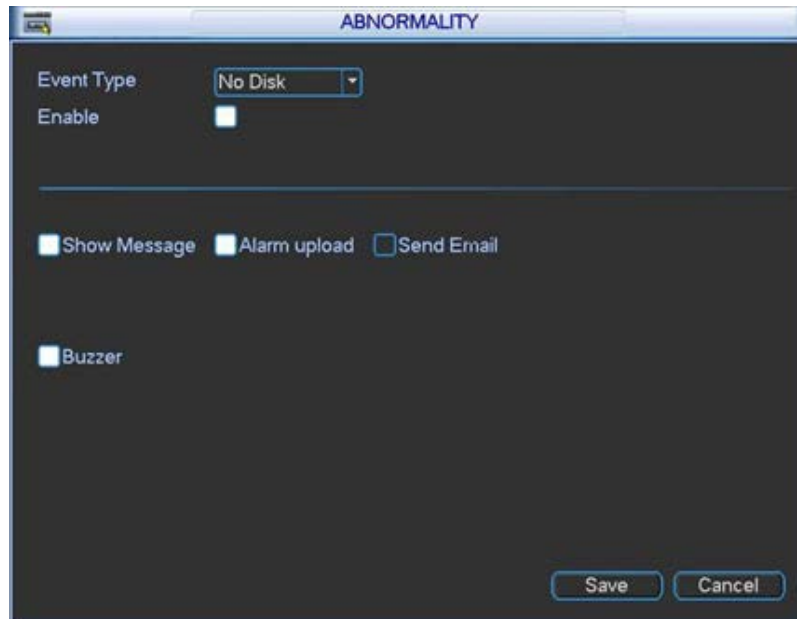

Figure 3-40

Select the desired event from the Event Type field and then indicate the way(s) you would like to be notified that the event has occurred. Click **Save** after making your selections.

Event Type

Use the drop-down menu to select the event that triggers the Abnormality. Select from No Disk, Disk Error, No Disk Space, Network Disconnection, IP Conflict and MAC Conflict.

Enable

Check this box to enable an alert for the item selected in **Event Type**.

Show Message

If this box is checked, a pop up message appears in the local screen to alert you that the event has occurred.

Alarm Upload

This option uploads an alarm signal to the network if your enabled event occurs.

Send Email

If the event occurs, the system sends out an email to the designated account.

Buzzer

If this box is checked, an audible alert tone within the DVR sounds when the designated event occurs.

3.5.3 Record

Refer to section **2.3 Recording** on page 8.

3.5.4 Account

The Account screen provides account management access. Here you can:

- Add new user
- Modify a user
- Add a group
- Modify a group
- Modify your password.

You can assign different rights to different groups and thereby apply the same rights to all users assigned to that group.

Note:

- The system account uses two-level management: group and user.
- The system supports a maximum of 20 user groups and 64 users.
- There are two levels for group or user management: admin and user.
- Each user should only belong to one group.
- User rights cannot exceed group rights.
- The system allows multiple users use the same account to login.

After all the settings have been made, click the **Save** button. The system returns to the previous menu.

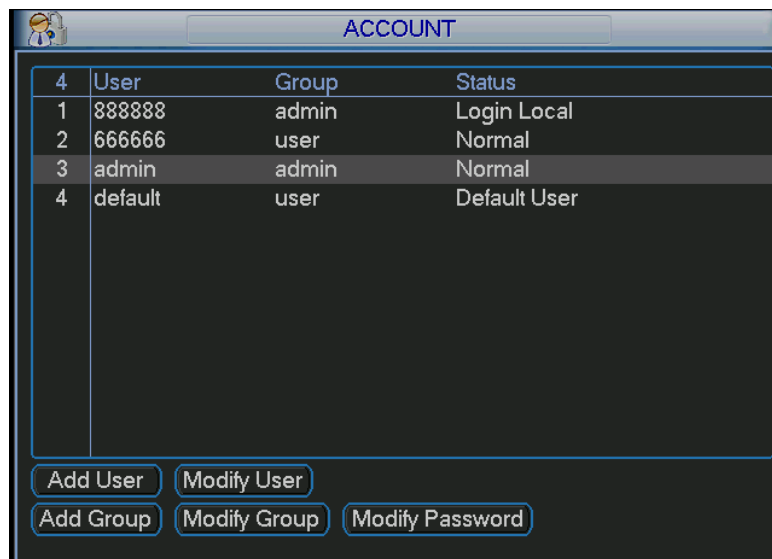

Figure 3-41

3.5.4.1 Modify Password

To modify the account password:

1. Click the **Modify Password** button. The Modify Password dialog appears as shown in Figure 3-42.
2. Select the account from the dropdown list,
3. Input the **Old Password**.
4. Enter the new password in the designated field, as well as in the **Confirm** field.
5. Click the **Save** button to confirm the change.

Note: If you have user account rights, you can also modify the passwords of other users.

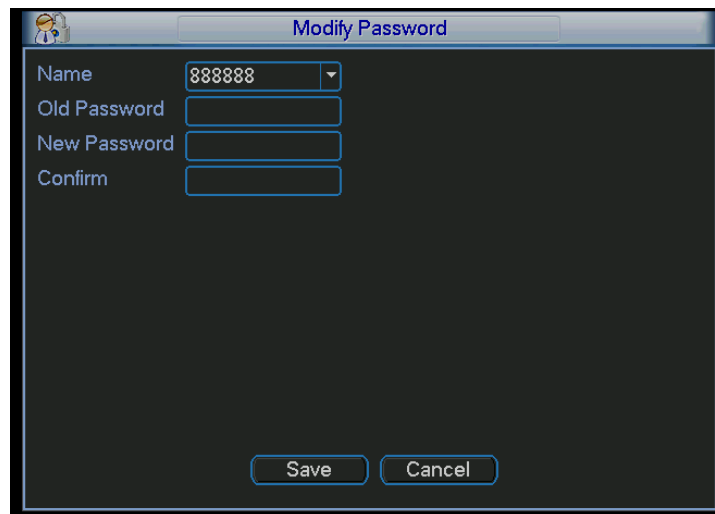

Figure 3-42

3.5.4.2 Add/Modify Group

A group is a convenient method for assigning a set of rights to multiple users. Usually a user would be assigned to a single group.

To add a new group:

1. Click the **Add Group** button in the **Account** screen. The **Add Group** dialog appears.

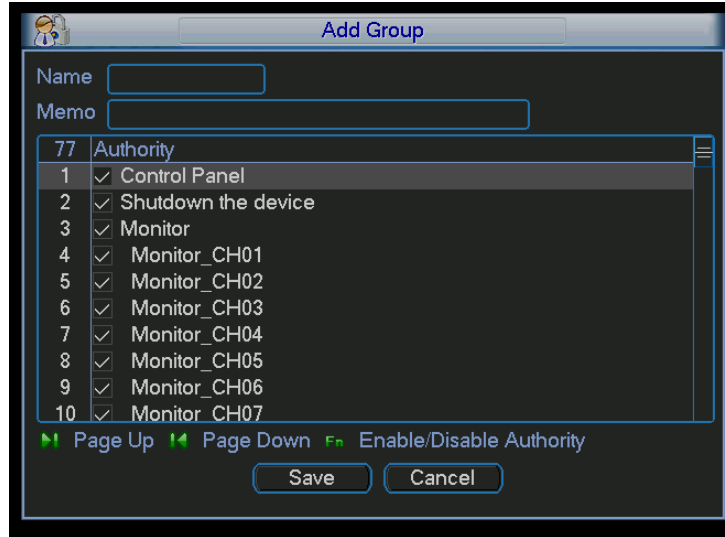

Figure 3-43

2. Enter a **Name** for the Group.

Note:

- For the user group name, the maximum string length is 6-bytes.
- The string can include letters, numbers, underscore, minus sign and period.
- The underscore must be in the middle of the string, not at the front or end of the string.

3. Optionally, enter a descriptive **Memo** for the Group.
4. Place a check in the box of the rights that you would like to assign to this group.
There are 60 different rights, such as control panel, shut down, real-time monitor, playback, record and user account.
5. Click **Save**.

To modify a group:

1. Click the **Modify Group** button in the **Account** screen. The **Modify Group** dialog appears.
2. Make the desired changes.
3. Click **Save**.

3.5.4.3 Add/Modify User

To add a new user:

1. Click the **Add User** button in the **Account** screen. The **Add User** dialog appears.

Figure 3-44

2. Enter the **User** name

Note:

- The maximum length for the user name string is 6-bytes.
- The string can include letters, numbers, underscore, minus sign and period.
- The underscore must be in the middle of the string, not at the front or end of the string.

3. Enter the user password in the **Password** and **Confirm** fields.

4. If desired, enter an optional **Memo** describing this user.

5. Enter the user MAC address, in 2-digit 0-f format. The system only saves lower case characters even you input the capitalized one (*f* instead of *F*).

When you add a new user, input the MAC address of the current user. Only the user of the same MAC address can access the device remotely. (MAC address is for the device of the same LAN.) If you leave the MAC address item blank when you add a new user, the user of any MAC address can access the device remotely. You can set or change the MAC address when you add or modify a user. The MAC address function is also valid for PSS login.

6. Select the Group this user belongs to from the dropdown list.

7. Select the corresponding rights for the current user.

8. Click **Save**.

It is recommended that the user rights are set lower than the administrative rights.

To modify a user:

1. Click the **Modify User** button in the **Account** screen. The **Modify User** dialog appears.
2. Make the desired changes.
3. Click **Save**.

3.5.5 Auto Maintenance

This screen enables automatic system reboot and deletion of old files at prescribed times.

To set or edit automatic maintenance:

1. Click the **Auto Maintain** icon in the **Advanced** screen (see Figure 3-37 on page 71). The Auto Maintenance dialog appears.
2. To Auto-Reboot the system, select from dropdown list the day and time you would like the reboot to occur.
3. To Auto-Delete Old Files, select from dropdown list the type of files to be deleted and the number of days-old that these files must be before being deleted.
4. After completing the setup, click the **OK** button. The system reverts to the previous menu.

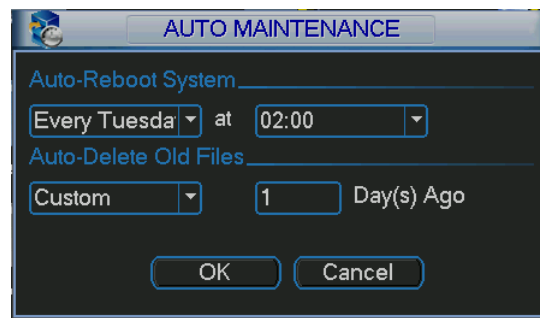

Figure 3-45

3.5.6 TV Adjust

The TV Adjust dialog enables you to make adjustments to the monitor screen.

To set or edit TV Adjust:

1. Click the **TV Adjust** icon in the **Advanced** screen (see Figure 3-37 on page 71). The **TV Adjust** dialog appears.
2. Drag the slide bar to adjust each item to the desired setting.
3. After completing the setup, click the **OK** button. The system reverts to the previous menu.

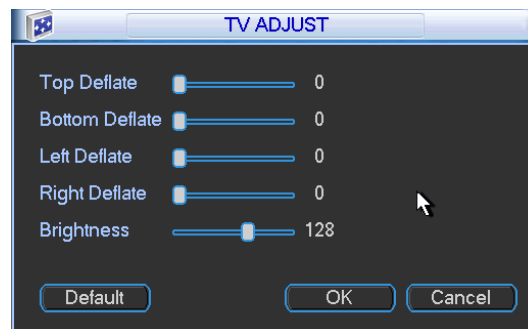

Figure 3-46

3.5.7 Text Overlay

The Text Overlay feature, which is intended for financial applications, overlays credit card information over the video image. The following describes the Text Overlay dialog, which varies depending on whether the protocol used.

Sniffer Mode

For the DVR5 1xxC Series, NET is the only selection from the drop-down menu.

Protocol

Select ATM/POS or POS. The dialog changes depending on the selection you make here.

Setting

Click this button to open the Setup dialog. Available options depend upon the selection made in Protocol. See details in the following sections.

Overlay Channel

If POS is selected for Protocol, this parameter appears to select the channels on which to apply the overlay.

Overlay Mode

Check the box for the option(s) you want to enable: Preview or Encode. Preview means the card number is overlaid in the live video. Encode means the card number is overlaid in the recorded file.

Overlay Position

From the dropdown list, select the position where you want the overlay to appear: Top Left, Top Right, Bottom Left or Bottom Right.

3.5.7.1 With the ATM/POS Protocol

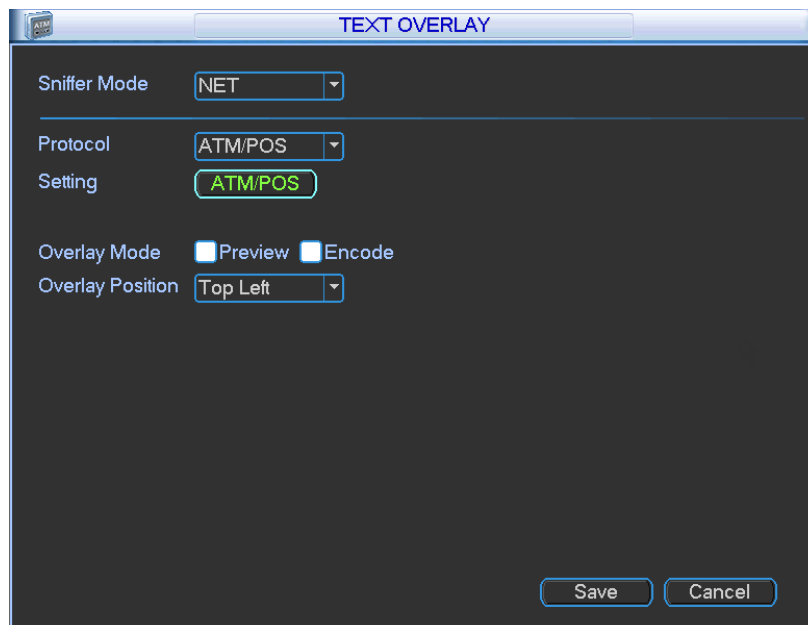

Figure 3-47

1. For Sniffer Mode, **NET** is the only selection from the drop-down menu.
2. For Protocol, select **ATM/POS** from the dropdown menu.
3. For Setting, click the **ATM/POS** button. The following setup dialog appears:

	StartPosition	Length	Key	
Frame ID1	1	1	bank	Data
Frame ID2	1	0		Data
Frame ID3	1	0		Data
Frame ID4	1	0		Data
Frame ID5	1	0		Data
Frame ID6	1	0		Data

Figure 3-48

4. Set the Source IP, Destination IP and Record Channels.
Source IP refers to host IP address that sends out information, which is usually the device host. The Destination IP refers to other systems that receive the information.

Note:

- Usually you will not need to set the source port and target port.
- There are four IP groups. The Record Channel applies only to one group (optional).

5. For the Frame ID groups, click the **Data** button to open the dialog shown in Figure 3-49.

Field	StartPosition	Length	Title
Field1	5	10	card
Field2	1	0	
Field3	1	0	
Field4	1	0	

Figure 3-49

- Here you can set offset value, length and title according to your communication protocol and data package.

Note: Having six Frame ID groups can help ensure validity of the information.

- Click **Save**.
- Select the Overlay Mode: Preview or Encode.
- Select the Overlay Position: Top Left, Top Right, Bottom Left or Bottom Right.
- Click **Save**.

3.5.7.2 Without the Protocol

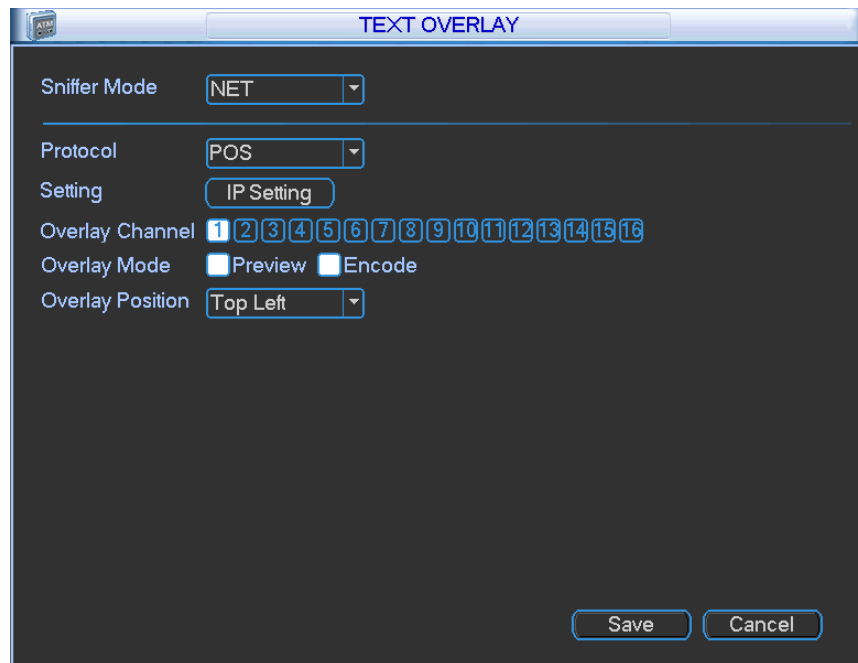

Figure 3-50

- For Sniffer Mode, **NET** is the only selection from the drop-down menu.
- For Protocol, select **POS** from the dropdown menu.
- For Setting, click the **IP Setting** button. The following dialog appears:

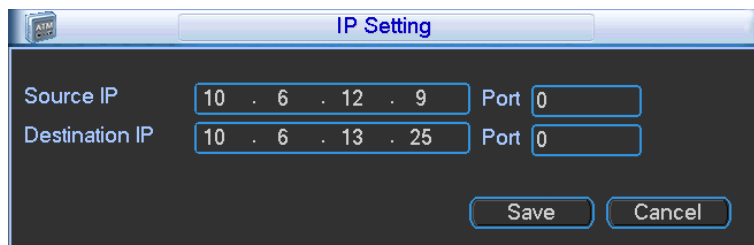

Figure 3-51

- Set the Source IP and Destination IP and click **Save**.

Source IP refers to host IP address that sends out information, which is usually the device host. The Destination IP refers to other systems that receive the information.

5. Select the Overlay Channels.
6. Select the Overlay Mode: Preview or Encode.
7. Select the Overlay Position: Top Left, Top Right, Bottom Left or Bottom Right.
8. Click **Save**.

3.5.8 Config Backup

The configuration file backup dialog enables you to import/export the system configuration. You can use this function when there are several devices that require the same setup.

Click the **Config Backup** icon in the Advanced screen (see Figure 3-37 on page 71). The Config Backup dialog appears.

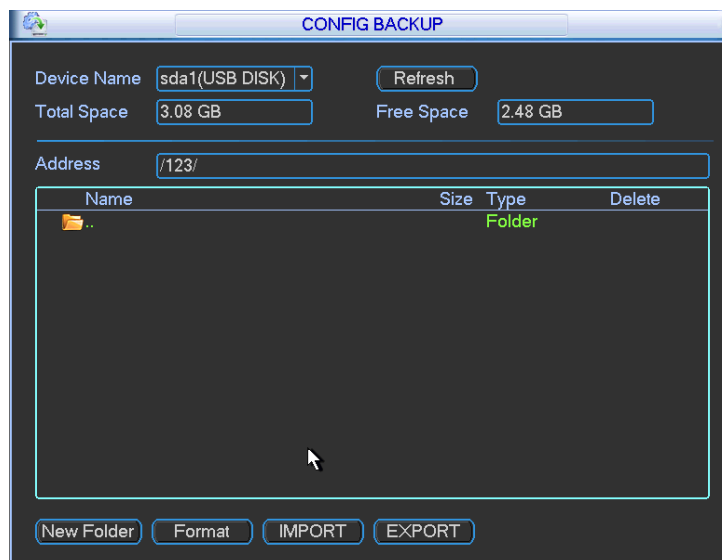

Figure 3-52

Export

1. Connect the peripheral device.
2. Initiate Config Backup.
3. Click the **Export** button. A corresponding **Config_Time** folder appears
4. Double click the **Config_Time** folder. Backup files are visible.

Import

Here you can import the configuration files from the peripheral device to current device. You must select a folder first. A dialog box asks you to select a folder if you are selecting a file. A dialog box pops up if there is no configuration file under current folder. After a successful import, the system needs to reboot to activate new setup.

Format

Click the **Format** button. A dialog box appears for you to confirm the current operation. The format process begins after you click the **OK** button.

Note:

- The system cannot open the Config Backup screen again if the backup operation is in progress.
- The system refreshes the device each time you use the Config Backup and sets the current directory as the root directory of the peripheral device.
- If you go to the configuration backup screen first and then insert the peripheral device, you must click the Refresh button to see the newly added device.

3.6 Information (Info)

Click the **Info** icon on the Main Menu to view system information. There are six items: HDD (hard disk drive information), BPS (data stream statistics), Log, Version, Online Users and Network Information.

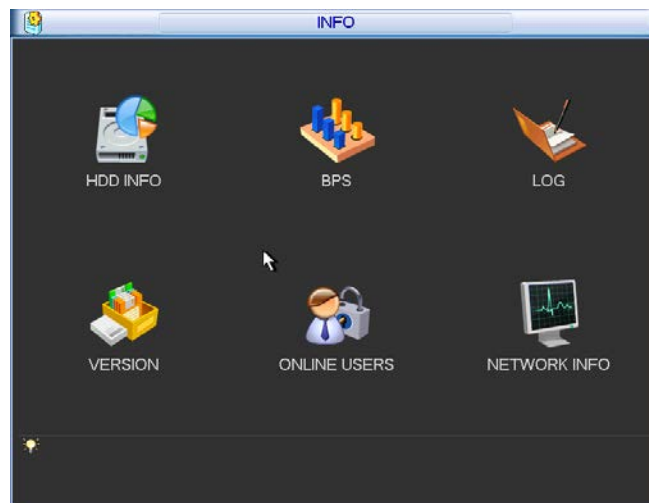

Figure 3-53

3.6.1 HDD Information

HDD Info lists the hard disk type, total space, free space, video start time and status. See Figure 3-54.

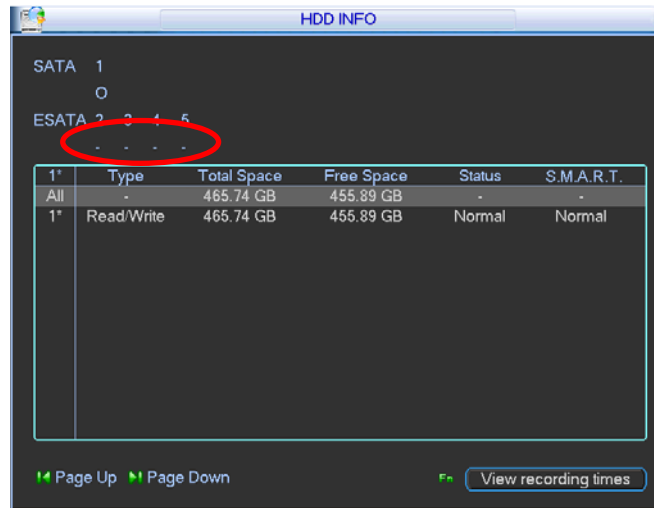

Figure 3-54

Status

- HDD is working normally
- X HDD error
- No HDD detected
- ? HDD is damaged and must be replaced

When a HDD conflict occurs, you can check whether the system time and HDD time are the same. If they are not identical, go to *Setting > General* (see section **3.3.1 General** on page 42) to adjust the system time or go to **3.5.1 HDD Management** (page 71) to format the HDD, and then reboot the DVR.

After the system has booted up, if there is any conflict, the system goes to the HDD Information dialog directly, although the system does not require that you deal with the conflict.

TIP: Left click the mouse to view HDD record time and HDD type and time.

Double click an item in the list to display the HDD Smart information screen for that HDD.

3.6.2 BPS

The BPS screen enables you to view current video data stream (KB/s) and occupied hard disk storage (MB/h) information. Click the BPS icon on the Info screen.

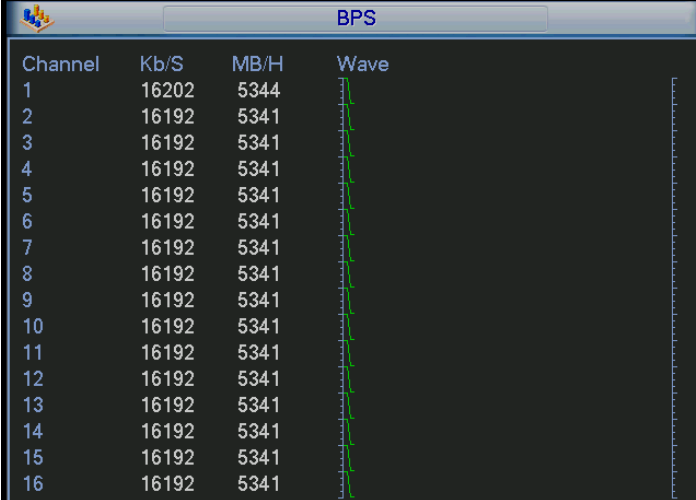

Channel	Kb/S	MB/H	Wave
1	16202	5344	
2	16192	5341	
3	16192	5341	
4	16192	5341	
5	16192	5341	
6	16192	5341	
7	16192	5341	
8	16192	5341	
9	16192	5341	
10	16192	5341	
11	16192	5341	
12	16192	5341	
13	16192	5341	
14	16192	5341	
15	16192	5341	
16	16192	5341	

Figure 3-55

3.6.3 Log

The Log screen enables you to view system log files. Log types include system operation, system configuration, data management, alarm event, record operation, log clear, file operation, etc. Click the **Log** icon on the **Info** screen (see Figure 3-53 on page 84) to open.

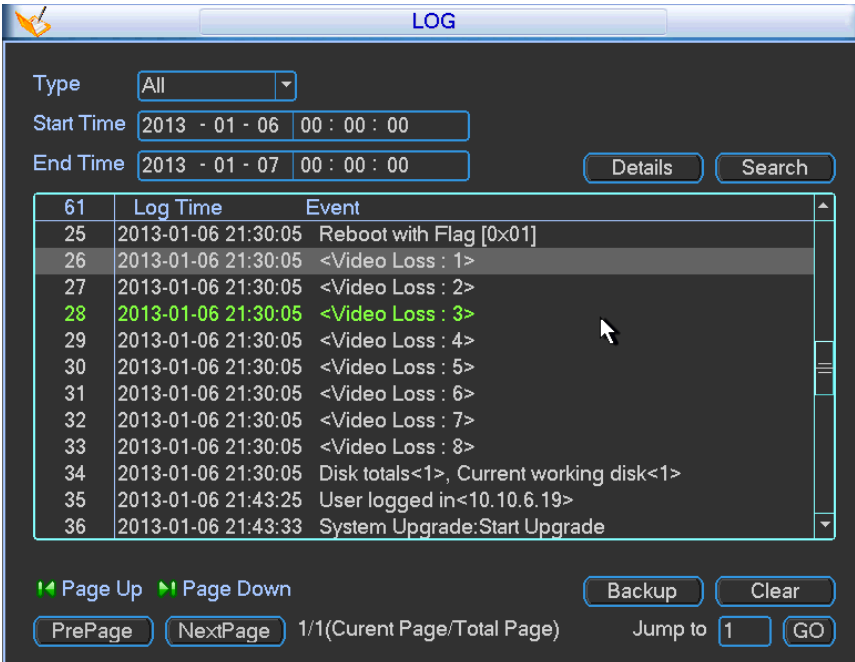

61	Log Time	Event
25	2013-01-06 21:30:05	Reboot with Flag [0x01]
26	2013-01-06 21:30:05	<Video Loss : 1>
27	2013-01-06 21:30:05	<Video Loss : 2>
28	2013-01-06 21:30:05	<Video Loss : 3>
29	2013-01-06 21:30:05	<Video Loss : 4>
30	2013-01-06 21:30:05	<Video Loss : 5>
31	2013-01-06 21:30:05	<Video Loss : 6>
32	2013-01-06 21:30:05	<Video Loss : 7>
33	2013-01-06 21:30:05	<Video Loss : 8>
34	2013-01-06 21:30:05	Disk totals<1>, Current working disk<1>
35	2013-01-06 21:43:25	User logged in<10.10.6.19>
36	2013-01-06 21:43:33	System Upgrade:Start Upgrade

Figure 3-56

Start Time/End Time

Select the start time and end time, and then click **Search** button. The log files are displayed in a list. The system displays a maximum of 100 logs in one page and can save a maximum of 1024 log files. Use the page up/down button in the dialog to view more.

Backup

Select the log files you want to save and click the **Backup** button to save. After the backup, a folder named **Log_time** appears in the backup path. Double click the folder to view the log file.

Details

Click the **Details** button or double click the log item to view detailed information. Use the slider or Page up/Page down to view other log information. To playback the alarm event log such as video loss, click the **Playback** button at the bottom right corner.

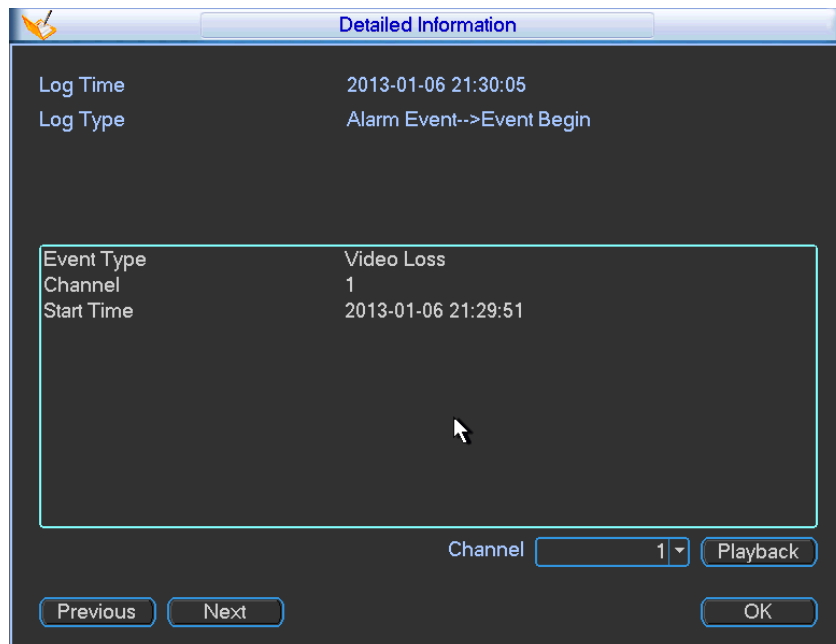

Figure 3-57

3.6.4 Version

Version enables you to view hardware features, software version, built date, release SN information, etc. You can also update system here. See Figure 3-58. Click the **Version** icon on the **Info** screen (see Figure 3-53 on page 84) to open the screen.

To initiate an update, insert the USB device that has the update file to the device, and then click the **Start** button to begin.

IMPORTANT: Make sure the upgrade file is named *update.bin*.



Figure 3-58

3.6.5 Online Users

This screen enables you to manage the Online Users. You can disconnect one user or block one user if you have proper system rights. The maximum disconnection setup time is 65535 seconds. Click the **Online Users** icon on the **Info** screen (see Figure 3-53 on page 84) to open the screen.

The system refreshes every five seconds to detect whether a user has been added or deleted.

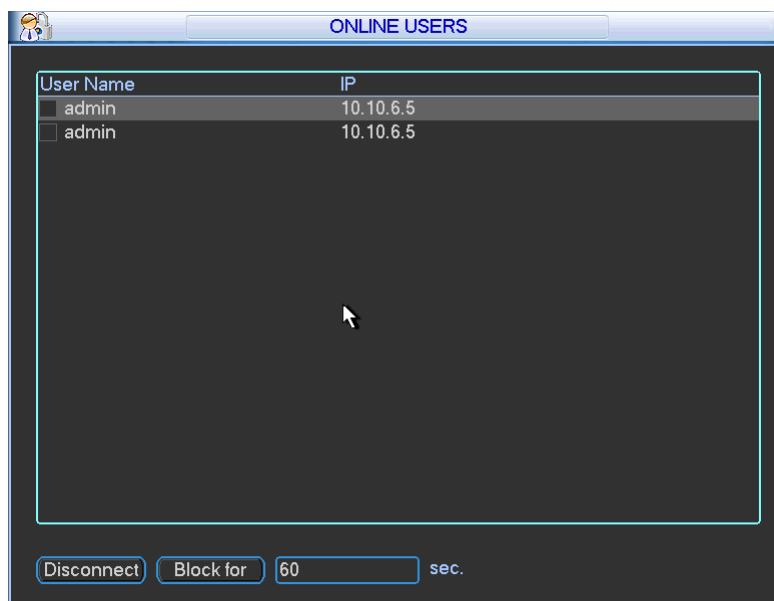

Figure 3-59

3.6.6 Network Information

In this screen, you can see the Network Test and Network Load information. Click the **Network Info** icon on the **Info** screen (see Figure 3-53 on page 84) to open the dialog.

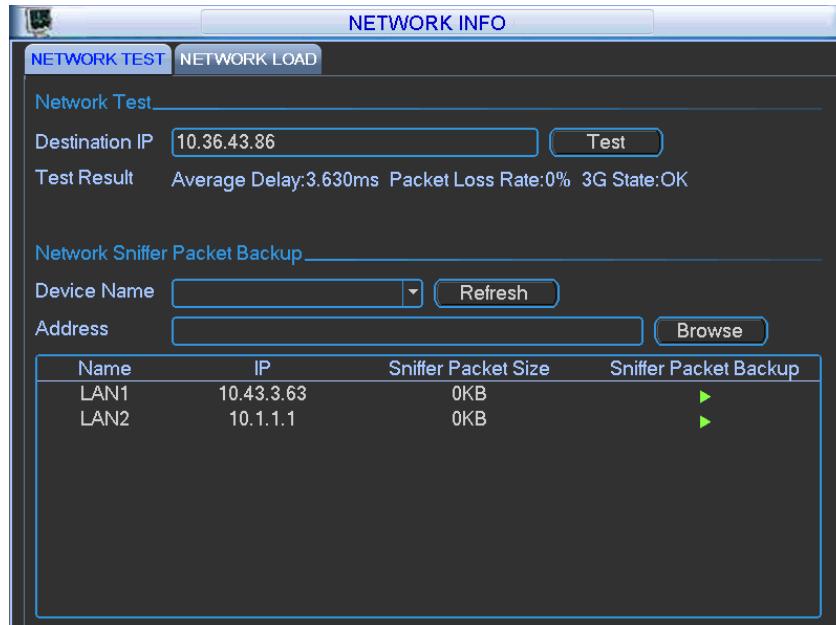

Figure 3-60

3.6.6.1 Network Test

The Network Test tab is displayed in Figure 3-60.

Destination IP

Input a valid IPV4 address and domain name.

Test

Click to test the connection with the destination IP address. The test results display the average delay and packet loss rate. You can view the network status as OK, bad, no connection, etc.

Network Sniffer Backup

1. Insert a USB2.0 device and click **Refresh**. View the device in the following column.
2. Use the dropdown list to select the peripheral device.
3. Click the **Browse** button to select the snap path. The steps here are the same as for the backup operation. You can view all connected network adapter names, including Ethernet and PPPoE. (WIFI and 3G are not supported by ADT at this time.)
4. Click the ▶ button on the right panel to begin the Sniffer.
5. Click the gray **Stop** button to stop. Note that the system cannot Sniffer multiple network adapters at the same time.
6. After Sniffer begins, you can exit to implement corresponding network operations such as login WEB, or monitor.

7. Return to the Sniffer dialog and click  to stop the Sniffer.

The system can save the packets to the specified path. The file is named with the format "Network adapter name + time". You can use software such as Wireshark to open the packets on the PC to solve complicated problems.

3.6.6.2 Network Load

Click the **Network Load** tab to view the follow statistics of the device network adapter.

Here you can view information of all connected network adapters. The connection status is shown as offline if the connection is disconnected. Click a network adapter to view the flow statistics, such as send rate and receive rate in the top panel.

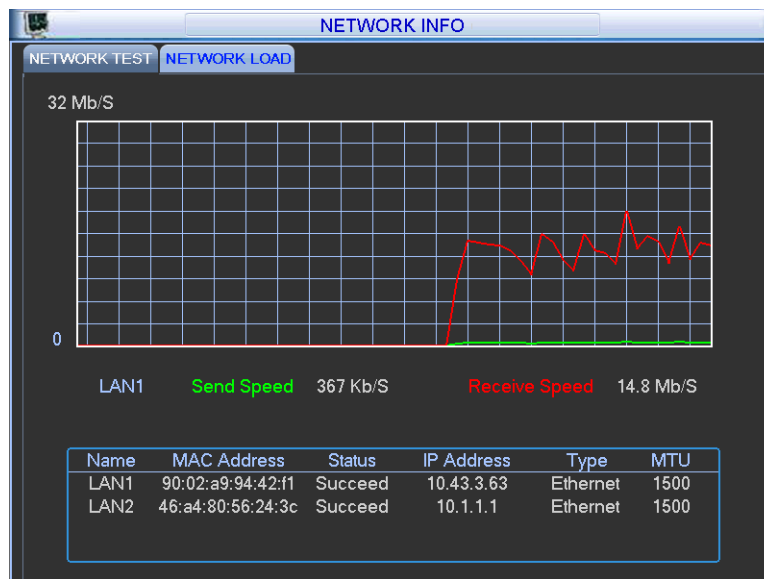

Figure 3-61

3.7 Shutdown

Double click the **Shutdown** icon in the Main Menu. The following dialog appears.



Figure 3-62

Make your selection from the drop down menu.

Logout Menu User

Click this to log out. You must enter your password when you log in the next time.

Restart Application

Select to reboot the DVR.

Shutdown

The system shuts down and power is turned off.

Restart System

Initiates a system reboot.

Switch User

Select to switch to another user account to log into.

4 Web Service

The web service contains the same functions as are available in local operation.

Note: There might be a slight difference in the screen depending on the model. The following examples are for the 8-channel product.

4.1 Network Connection

Before web operation, check the following items:

1. Verify that you have a valid network connection.
2. Verify that the DVR and PC network setup is correct. Refer to network setup (*Setup > Network*).
3. Ping the DVR IP address (**.*.*.*.*) to verify that the connection is good. The return TTL value is usually less than 255.
4. Open a browser window and input the DVR IP address.

The system automatically downloads the latest web control and overwrites the previous one if necessary.

5. To uninstall the web control, run *uninstall webrec3.0.bat*. Alternatively, you can go to *C:\Program Files\webrec* to remove a single folder. Before you un-install, be sure close all web pages to avoid errors.

Note: The DVR5 1xxC Series supports most web browsers, such as Internet Explorer, Safari, Firefox and Chrome. The device only supports 1-channel monitor on the Apple PC.

4.2 Login

To log in:

1. Open the browser and input the DVR IP address. For example, if your DVR IP is 10.10.3.16, then input <http://10.10.3.16>.

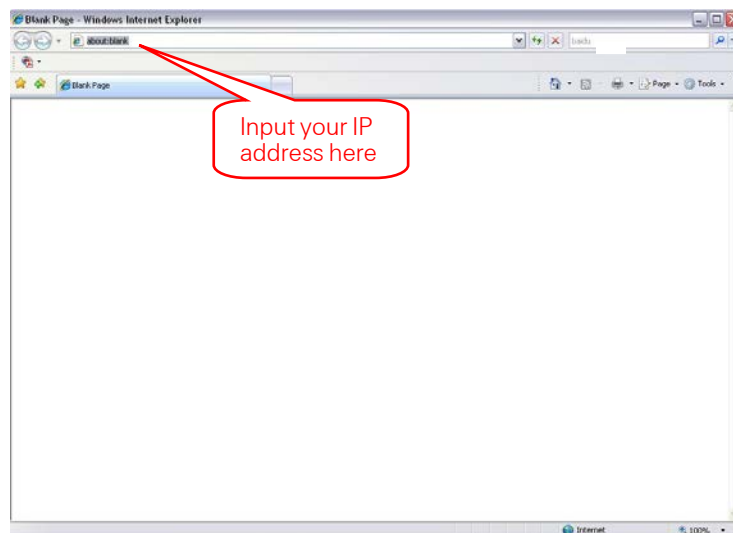

Figure 4-1

A pop up window appears asking you whether to install the *webrec.cab* control.

2. Click **Yes** to install *webrec.cab*.
3. If you can't download the ActiveX file, modify your browser settings as follows. (See Figure 4-2.)
 - a. Select **Internet Options** from the **Tools** menu. The Internet Options dialog appears.
 - b. Click the **Security** tab and click **Custom level**. The Security Settings dialog appears.
 - c. Scroll down the list and Enable the following options:
 - Download signed ActiveX controls
 - Download unsigned ActiveX controls
 - Initialize and script ActiveX controls

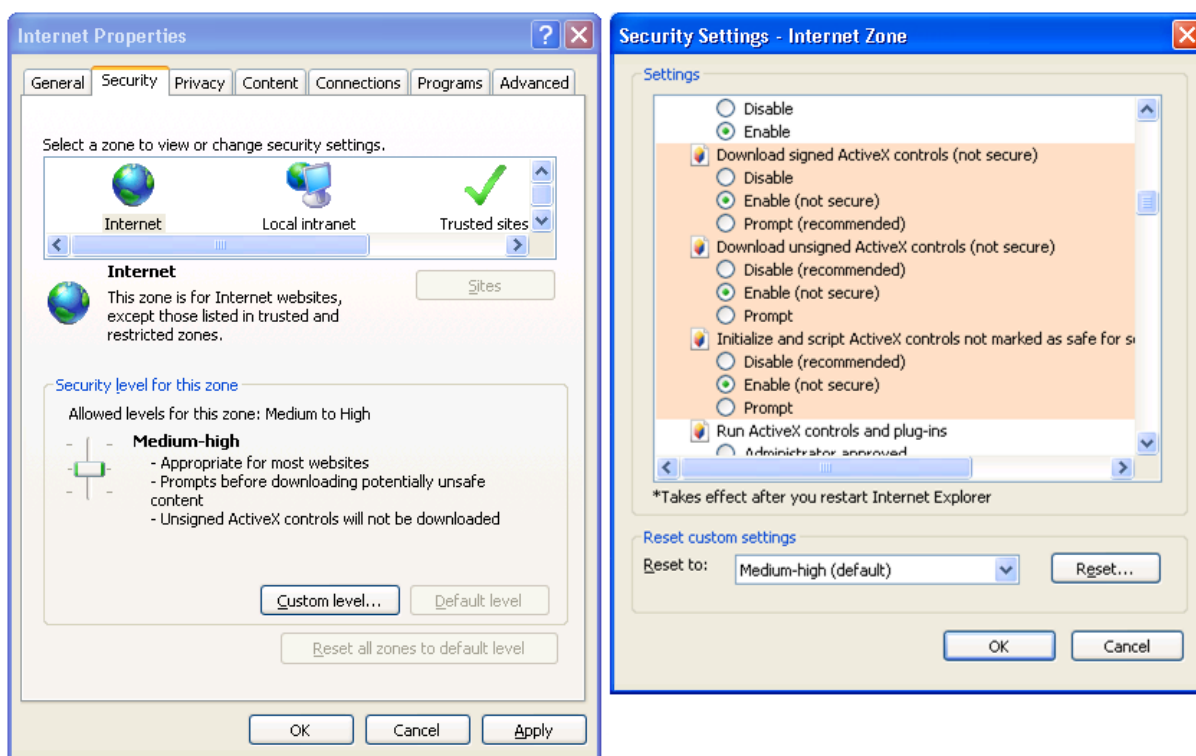

Figure 4-2

4. Click **OK** in both dialogs.
5. After installation, the Web Service page appears.

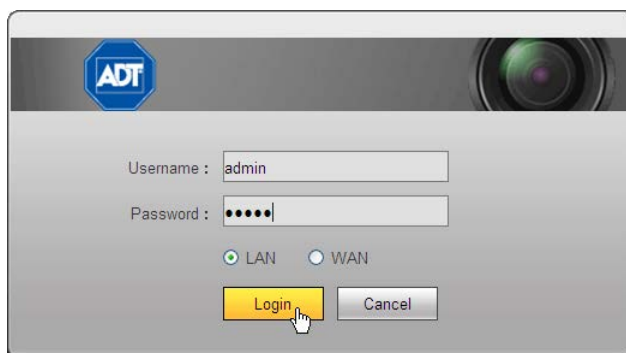

Figure 4-3

6. Input your **Username** and **Password**.
7. The default factory name is **admin** and password is **admin**.
8. Select the login mode: **LAN** or **WAN**.

Note: For security reasons, modify your password after you first login.

The Main web service window opens in the Live Tab.

4.3 Live Tab

The Live tab displays the real-time output of the video channels in the system. The window is laid out slightly differently, depending on whether you selected LAN or WAN Mode at log in. The WAN screen is essentially the same as for LAN, with the following exceptions:

In the LAN mode:

1. The Web Service opens with four channel windows by default. No video is displayed.
2. The Open/Close and CAM buttons in the left pane are used to open the video stream.

In the WAN mode:

1. The Web Service opens the Main Stream of the first channel only.
2. The Open/Close button in the left pane is removed.
3. You select different channel and different monitor modes at the bottom of the screen:

The other tabs on the web service operate the same regardless of whether you selected LAN or WAN Mode. There are five function tabs:

- **Live**, described in **4.3.3 Real-time Monitor** on page 100
- **Playback**, described on page 100
- **Alarm**, described on page 105
- **Setup**, described on page 105
- **Logout**, described on page 162

IMPORTANT:

- For multiple-channel monitor mode, the system displays in Sub Stream by default. You cannot modify this manually. All channels are trying to synchronize. The synchronization effect depends on your network environment.
- For bandwidth considerations, the system cannot support live viewing and playback at the same time. The system automatically closes the monitor or playback screen when you are conducting a search, in order to enhance search speed.

To skip to the discussion of LAN Mode and move on to WAN Mode, go to page 98.

4.3.1 LAN Mode

After logging into the LAN mode, the main window appears.

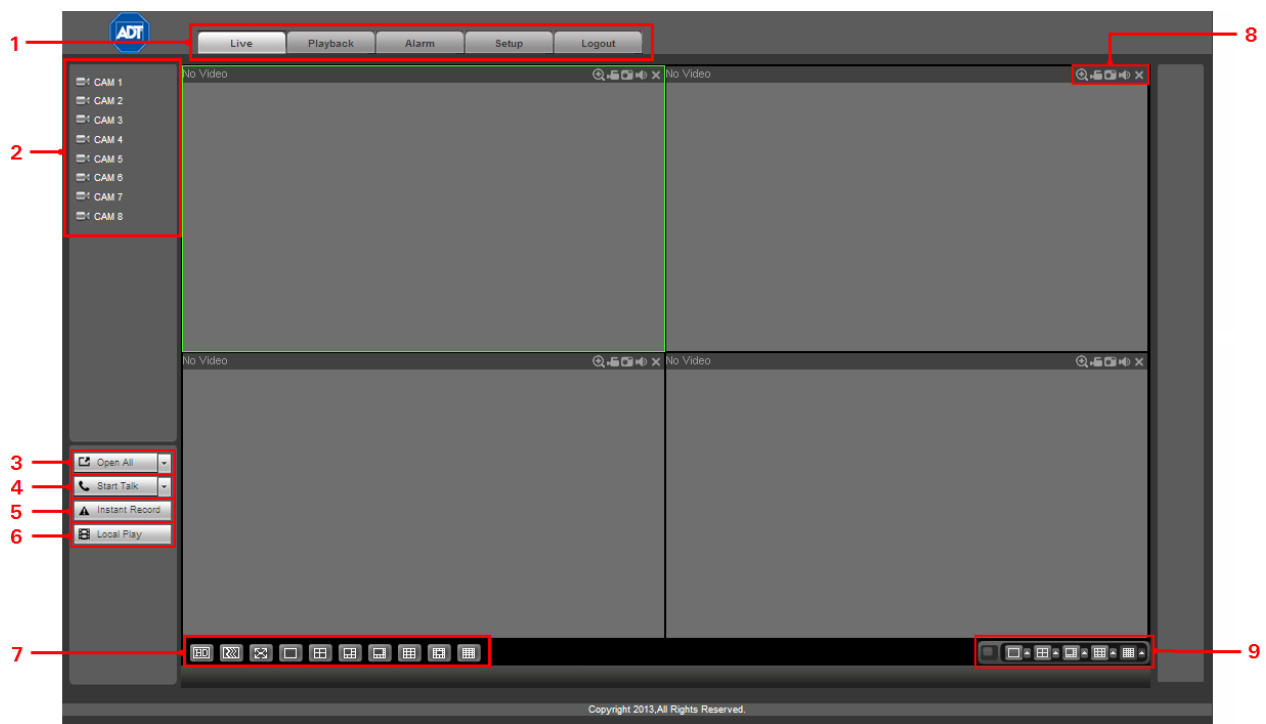

Figure 4-4

Section 1

Click the tab of the function you want to switch to: Playback, Alarm, Setup or Logout.

Section 2

This section displays the available individual camera channels that you can select. To initiate a specific camera, click the CAM icon for that camera. For sample, click on CAM 1 and select either Main Stream for full HD or Sub Stream for lower bandwidth display.

In the sample screens that follow, CAM 1, CAM 2, CAM 3 and CAM 6 have all been selected to output sub stream. The icon for each selected camera becomes yellow and the **S** designation (for Sub Stream) appears to the right of each. **M** would appear for HD Main Stream.

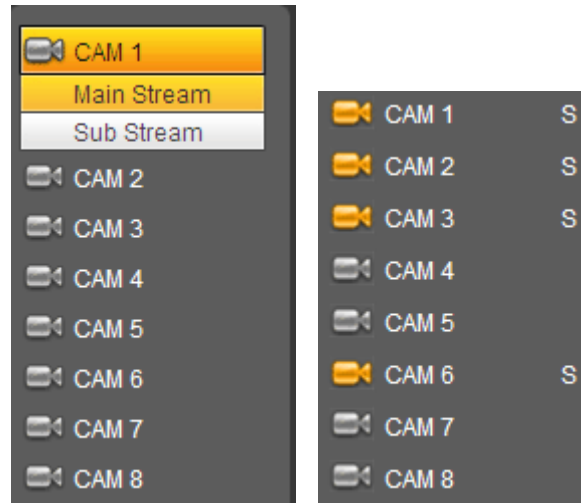

Section 3

Alternatively, you can use the **Open All/Close All** button to enable/disable all-channels at once. When you click the button, it becomes yellow.



Section 4

Start Talk button. Click this button to enable audio talk.

Note: ADT does not support Audio functions at this time.

Section 5

Instant Record button. When you click this button, it becomes yellow and the system begins manual record mode. Click it again to restore the system to the previous record mode.

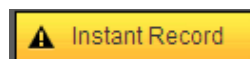

Section 6

Local Play button. The Web Service can playback recorded files that you have saved locally on your PC. Click the Local Play button and a popup screen appears for you to select local play files. Saved files have the extension name of **.dav.**) Navigate for the desired files and click **Open.**

Section 7

Video Display Parameters. From the left to the right are buttons that control screen display parameters, as described below.

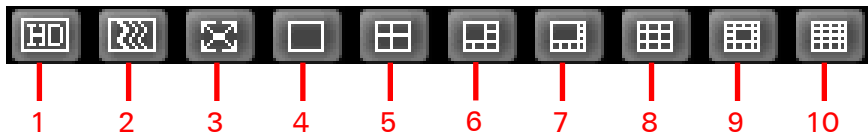

- | | | |
|--------------------|-------------------|---------------------|
| 1–Video quality | 5–4-window screen | 8–9-window screen |
| 2–Video fluency | 6–6-window screen | 9–13-window screen |
| 3–Full screen mode | 7–8-window screen | 10–16-window screen |
| 4–1-window screen | | |

Section 8

Function Buttons. On the top right corner are located six function buttons, which provide instant access to the following features: digital zoom, local record, snapshot picture and close video.

Section 9

Multiple Channel View. The system allows you to view several channels on one channel. This function determines the group of channels that are displayed, depending on the number of windows being displayed 1, 4, 8, 9 or 16.

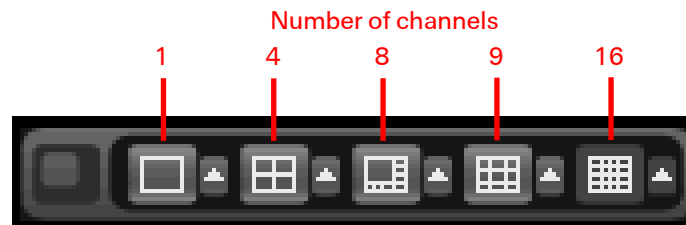

4.3.2 WAN Mode

After logging into the WAN mode, the main window appears.



Figure 4-5

Section 1

Click the tab of the function you want to switch to: Playback, Alarm, Setup or Logout.

Section 2

This section displays the available cameras. To initiate a specific camera, click the CAM icon for that camera on the left side of the screen. For sample, click on CAM 1 and select either Main Stream for full HD or Sub Stream for lower bandwidth display.

In the sample screens that follow, CAM 1, CAM 2, CAM 3 and CAM 6 have all been selected to output sub stream. The icon for each selected camera becomes yellow and the **S** designation (for Sub Stream) appears to the right of each. **M** would appear for HD Main Stream.

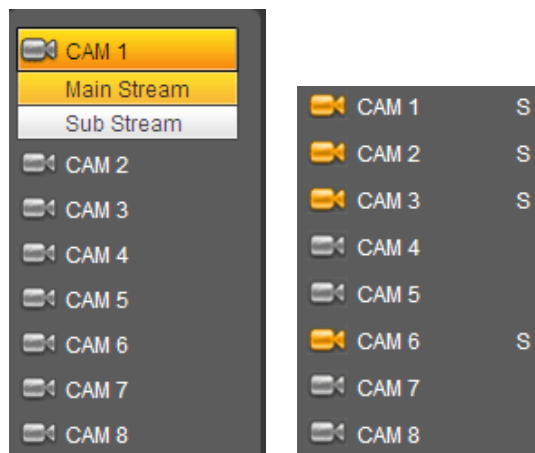

Section 3

Start Talk button. Click this button to enable audio talk.

Note: ADT does not support Audio functions at this time.

Section 4

Instant Record button. When you click this button, it becomes yellow and the system begins manual record mode. Click it again to restore the system to the previous record mode.



Section 5

Video Display Parameters. From the left to the right appear 7 buttons that control screen display parameters, as described below.

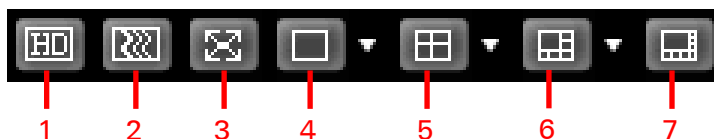

- 1-Video quality
- 2-Video fluency
- 3-Full screen mode
- 4-1-window screen mode
Click drop-down to select which channel is displayed: 1, 2, 3, 4, 5, 6, 7 or 8.
- 5-4-window screen mode
Click drop-down to select which channels are displayed: 1-4 or 5-8.
- 6-6-window screen mode
Click drop-down to select which channels are displayed: 1-6 or 3-8
- 7-8-window screen mode: 1-8

Section 6

Function Buttons. On the top right corner are located six function buttons, which provide instant access to the following features: digital zoom, local record, snapshot picture and close video.

4.3.3 Real-time Monitor

On the left side of the window, left click the channel name you want to view and the corresponding video appears in the current window.

On the top left corner, you can view the device IP, the channel number and the network monitor bit rate.

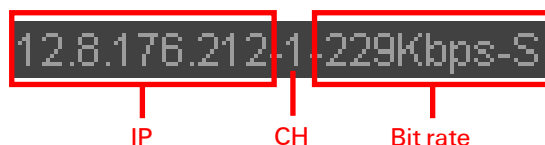

On the top right corner, there are six function buttons, which are described below.

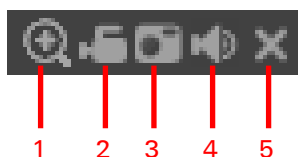

1-Digital zoom. Click this button and then left drag the mouse in the zone to zoom in. Right-click the mouse to restore the screen to its original status.

2-Local record. When you click Local Record button, the system begins recording immediately. The button becomes highlighted when selected. View the recorded file in the system folder named **RecordDownload**.

3-Snapshot picture. Click to take a still image of what is currently appearing on the screen. By default, all snapshot images are stored in the system client folder named **PictureDownload**.

4-Audio. Turn audio on or off.

Note: ADT does not support Audio functions at this time.

5-Close video. Turn off the video.

4.4 Playback Tab (Search)

This section describes how to search for a recorded file and then view it.

1. Click the **Playback Tab** button. The screen shown in Figure 4-6 appears.
2. Set the record type, record date, window display mode and channel name.
3. Click the date on the right pane to select the date.

The green highlighted date is system current date and the blue highlighted date means it has recorded files.

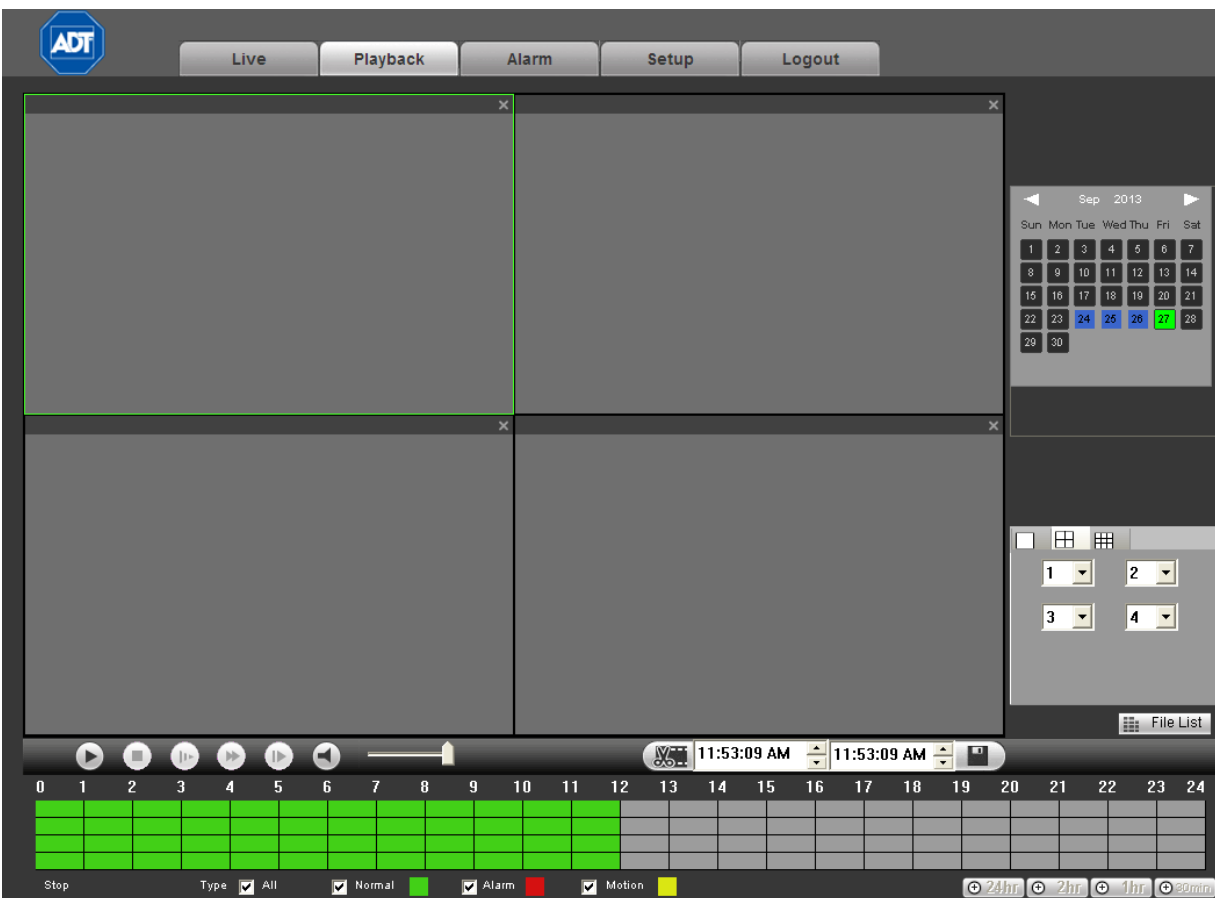

Figure 4-6

4. Click the **Search** button. The corresponding files in the list appear, as shown in Figure 4-7.

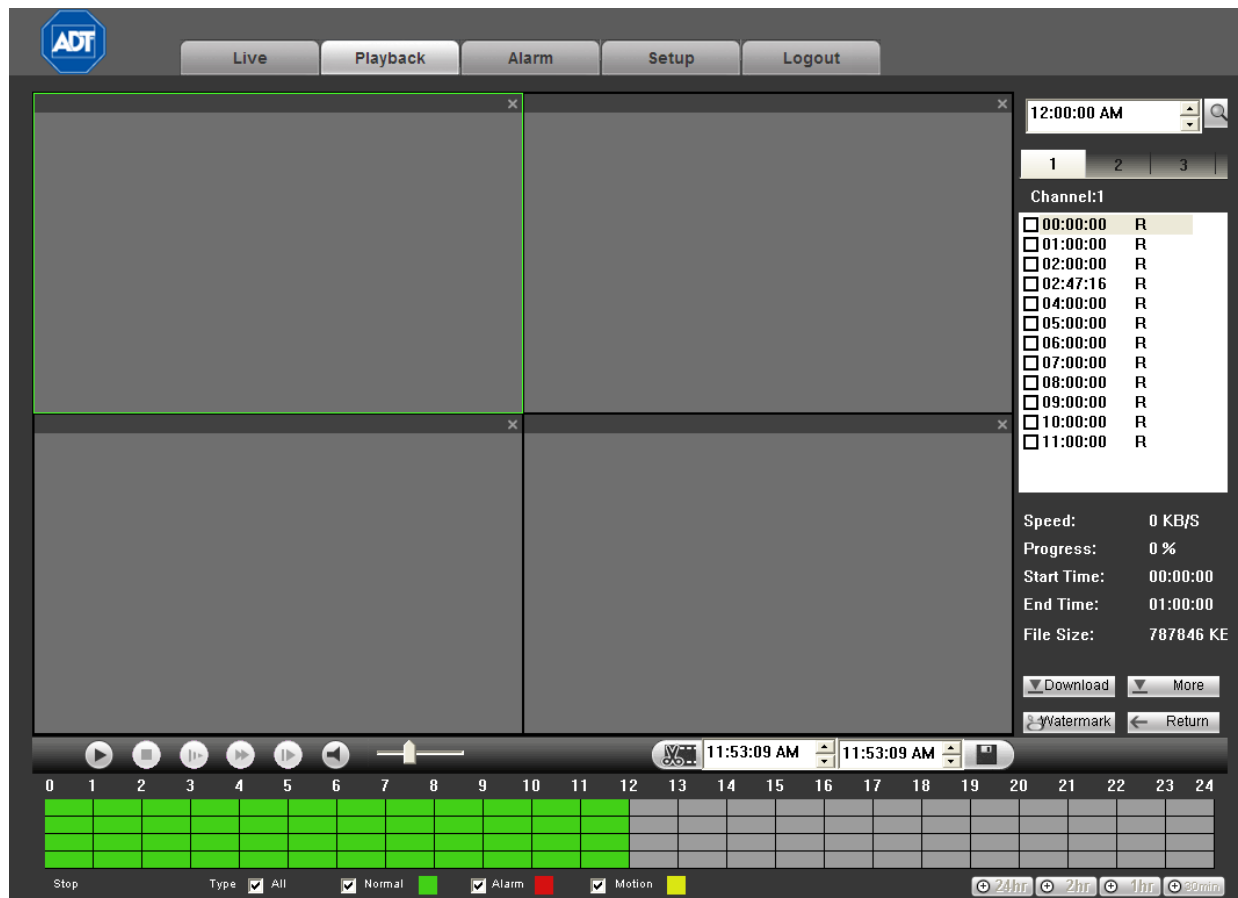

Figure 4-7

5. Select the file you want to play and then click the Play button ▶.

The system begins playback. You can select to playback in full-screen. Note that for one channel, the system cannot playback and download at the same time. The recording is automatically saved at the Download folder of the installation directory or you can download it to a specified directory.

6. Use the Playback Control Bar to implement various operations such as Play, Pause, Stop, Slow Play, and Fast Play. During playback you can view playback channel and device IP.
7. Select the file(s) you want to download and then click **Download** button. A dialog as shown in Figure 4-8 pops up where you can specify file name and path to download the file(s) to your local PC.
8. Navigate to the desired location and click **Save**.

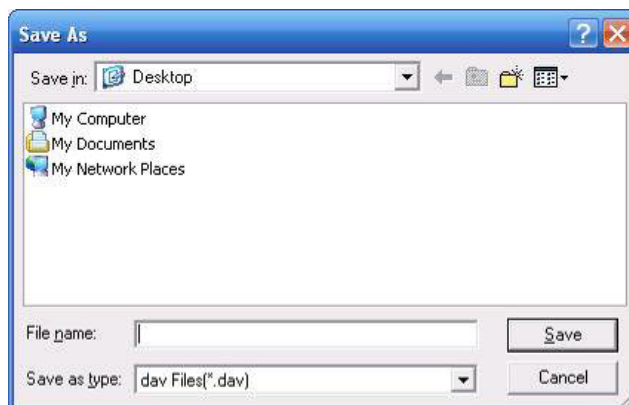

Figure 4-8

More

This interface is for searching for recordings or pictures. You can select Record Channel, Record Type and Record Time to Download. See Figure 4-9.

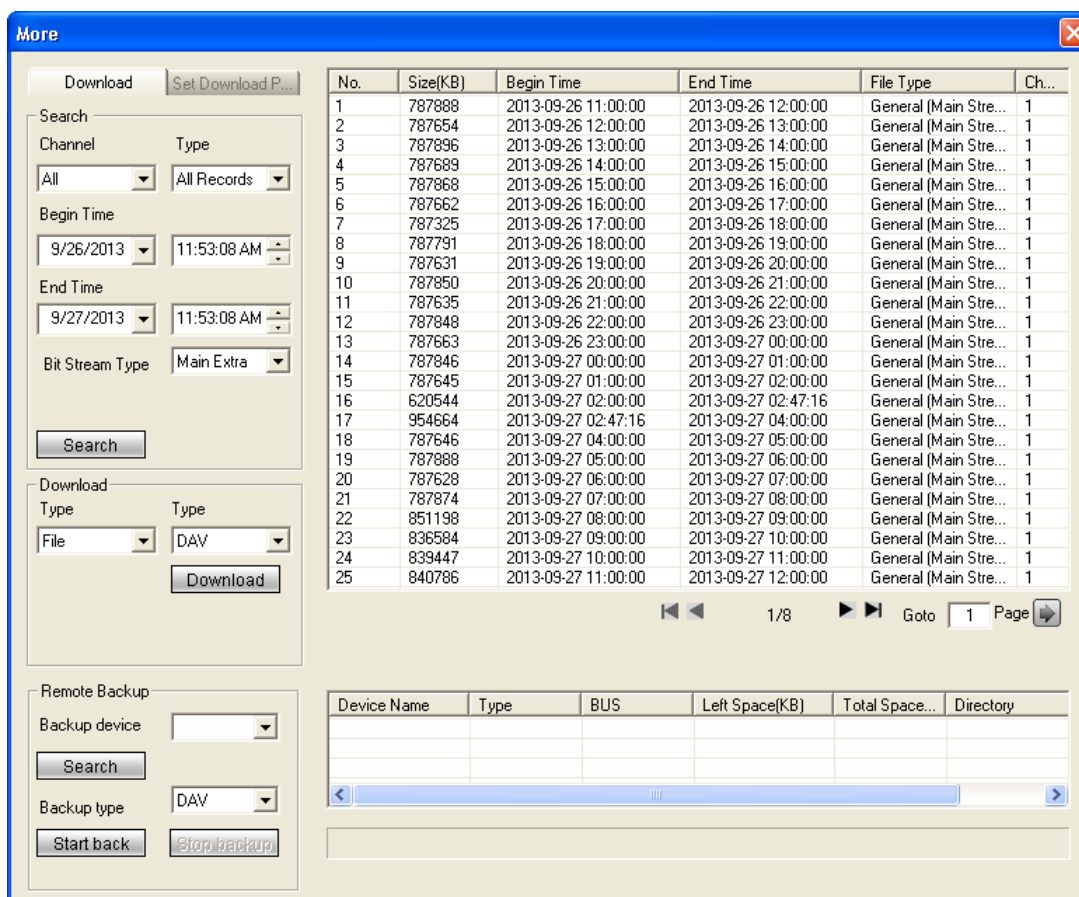

Figure 4-9

Remote Backup

The Remote Backup pane at the left bottom of the pane enables you to backup the recording or picture to your local USB storage media via the Web remotely. Click the **Search** button. The available storage device appears in the window. See Figure 4-10. Select file(s) from the list and then click the **Start backup** button. Refer to the **Path** section on page 111 to set device download path.

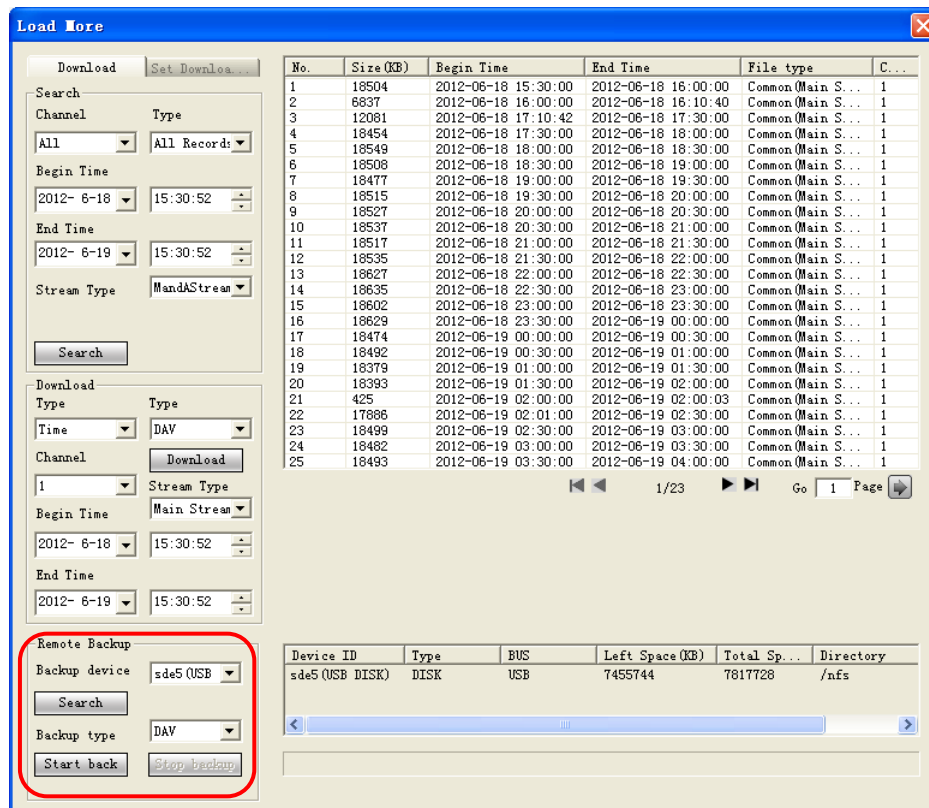

Figure 4-10

The system begins the backup and the **Stop backup** button becomes valid. Click it to terminate the current operation.

A progress bar appears at the bottom of the interface.

4.5 Alarm

The Alarm tab enables you to set the device alarm type and alarm sound setup.

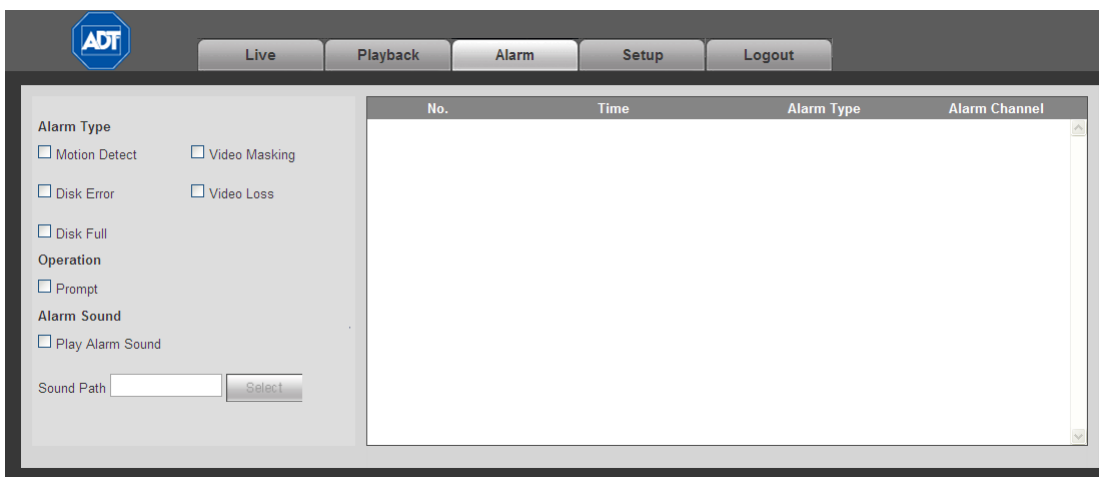

Figure 4-11

Refer to the following for detailed information.

4.5.1 Alarm Type

- Video Loss.** The system alarms when video loss occurs.
- Motion Detect.** The system alarms when a motion detection alarm occurs.
- Video Masking.** The system alarms when the camera is maliciously covered.
- Disk Full.** The system alarms when the hard disk is full.
- Disk Error.** The system alarms when a disk error occurs.

4.5.2 Operation

- Prompt.** An alarm icon pops up on the Alarm button on the main screen when there is an alarm.

4.5.3 Alarm Sound

- Play Alarm Sound.** The system sends out an audible alarm when an alarm occurs.
- Sound Path.** Specify the alarm sound file.

4.6 Setup

The setup page provides a location for setting parameters for Channel, Network, Event, Storage, System, Advanced and Information.

4.6.1 Channel

The Channel section provides a location for setting parameters for Conditions, Video & Audio and Channel Name.

4.6.1.1 Conditions

The Conditions area enables you to set property information. The settings become valid immediately after you save them.

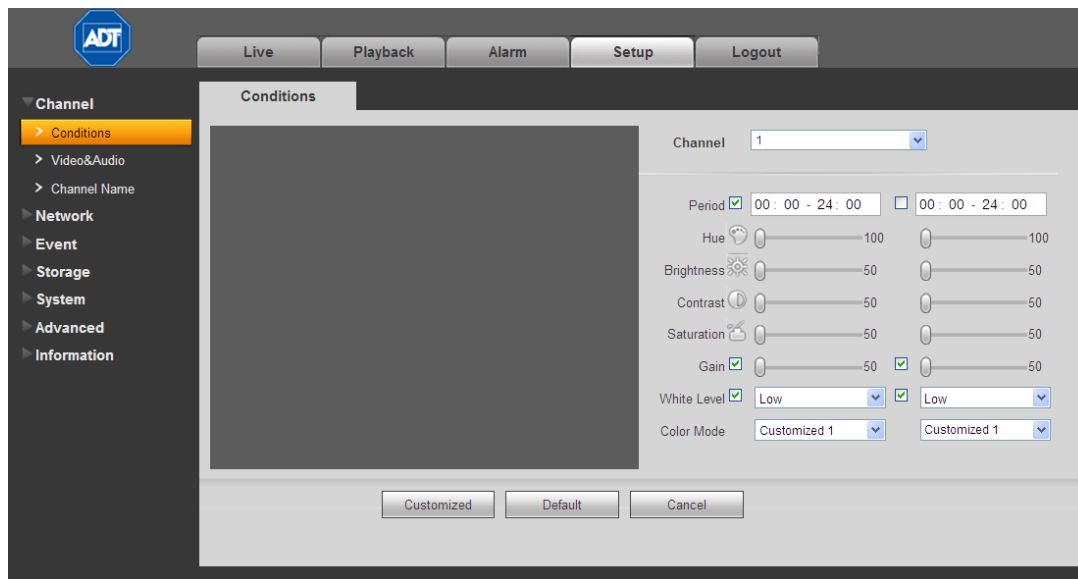

Figure 4-12

Refer to the following for detailed information.

Channel

Select a channel number from the drop-down list.

Period

This setting divides one day (24 hours) into two time periods. You can set different hue, brightness, and contrast for day or night.

Hue

This setting adjusts monitor video brightness and darkness level. The default value is 50. The greater the value is, the greater the contrast between the bright and dark sections.

Brightness

This setting adjusts monitor window brightness. The default value is 50. The greater the number is, the brighter the video. When you input the value here, the bright section and the dark section of the video will be adjusted accordingly. You can use this function when the whole video is too dark or too bright. Note that the video may become hazy if the value is too high. The value ranges from 0 to 100. The recommended value ranges from 40 to 60.

Contrast

This setting adjusts the monitor window contrast. The value ranges from 0 to 100. The default value is 50. The greater the number, the greater the contrast. Use this function when the overall video brightness is OK but the contrast is poor. Note that that the video may become hazy if the value is set

too low. If this value is too high, darker sections may lack brightness while the brighter section may appear over exposed. The recommended value ranges from 40 to 60.

Saturation

This setting is for adjusting monitor window saturation. The value ranges from 0 to 100. The default value is 50. The greater the number, the more intense the color. This value has no effect on the general brightness of the video as a whole. The video color may become too intense if the value is set too high. For the gray part of the video, distortion may occur if the white balance is not accurate. Note that video quality may appear poor if the value is set too low. The recommended value ranges from 40 to 60.

Gain

This function sets the gain value. The smaller the value, the lower the noise. (However, lower gain may result in a brightness setting too low in the dark environments.) A higher gain value can enhance the video brightness but video noise may increase.

White Level

The setting enhances video effects. Select from Low, Middle or High.

Color Mode

This includes several preset color modes for adjusting the hue, brightness, contrast, etc. Selections include: Standard, Soft, Bright, Colorful, Bank or Custom.

4.6.1.2 Video and Audio

Encode

Video compression settings are made in the Encode screen.

The screenshot displays the ADT web interface for video and audio encoding settings. The interface is divided into several sections:

- Navigation:** A top bar with tabs for Live, Playback, Alarm, Setup (selected), and Logout. A left sidebar menu includes Channel, Video & Audio (selected), Network, Event, Storage, System, Advanced, and Information.
- Encode Settings:**
 - Channel:** A dropdown menu set to '1'.
 - Main Stream:**
 - Code-Stream Type: Regular
 - Compression: H.264
 - Resolution: D1
 - Frame Rate(FPS): 30
 - Bit Rate Type: CBR
 - Bit Rate: 2048 Kb/S
 - Reference Bit Rate: 896-5120Kb/S
 - Sub Stream:**
 - Video Enable:
 - Compression: H.264
 - Resolution: CIF
 - Frame Rate(FPS): 7
 - Bit Rate Type: CBR
 - Bit Rate: 160 Kb/S
 - Reference Bit Rate: 48-320Kb/S
 - Audio Settings:**
 - Audio Enable:
 - Audio Encode: G711a
 - Watermark Settings:**
 - Watermark Enable:
 - Watermark String: (empty field)
- Buttons:** Copy, Save, Refresh, and Default.

Figure 4-13

Refer to the following for detailed information. After making your selections, click **Save**.

Channel

Select a single channel number or **All** from the dropdown list.

Video Enable

Check the box to enable Sub Stream (lower bandwidth) video. This item is enabled by default.

Code Stream Type

This includes main stream and motion stream. Select different encode frame rates from different recorded events. The system supports Active Control Frame function (ACF), which enables you to record in different frame rates. For example, you can use a high frame rate to record important events, record scheduled events at a lower frame rate and set different frame rates for motion detection recording.

Compression

Main Stream video supports H.264. The Sub Stream supports H.264, MJPG.

Resolution

The system supports various resolutions. Make your selection from the dropdown list. Main Stream supports D1/HD1/2CIF/CIF/QCIF and Sub Stream supports CIF/QCIF.

Frame Rate

Select a value in frames per second. (PAL: 1–25 f/s; NTSC: 1–30 f/s)

Bit Rate Type

Select CBR for Constant Bit Rate or VBR for Variable Bit Rate.

Bit Rate

Main Stream Video: Set the bit rate to change the video quality. The larger the bit rate, the better the quality. Refer to the Reference Bit Rate below.

Sub Stream Video: In CBR mode, the bit rate here is the maximum value. In dynamic video, the system needs to lower the frame rate or video quality to ensure this value.

Reference Bit Rate.

This lists the recommended bit rate range according to the resolution and frame rate you have set.

Audio Enable*

Check the box to enable audio recording.

*** Note: ADT does not support Audio functions at this time.**

Audio Encode*

If enabled, make your selection from the dropdown: G711a, PCM or G711u.

*** Note: ADT does not support Audio functions at this time.**

Watermark Enable

Check the box to enable a watermark on the video to verify whether the video has been tampered with.

Watermark String

If enabled above, enter the string you want to appear in the watermark. The default is Digital CCTV. The maximum length is 85 characters (alpha-numeric and the underline symbol).

Buttons

- Copy.** Click this button to copy the current channel's setup to other channels.
- Save.** Click to save the changes you have made.
- Refresh.** Click to refresh the web connection.
- Default.** Click to return settings on this page to their default values.

Snapshot

You can use the Snapshot screen for setting parameters for taking still images.

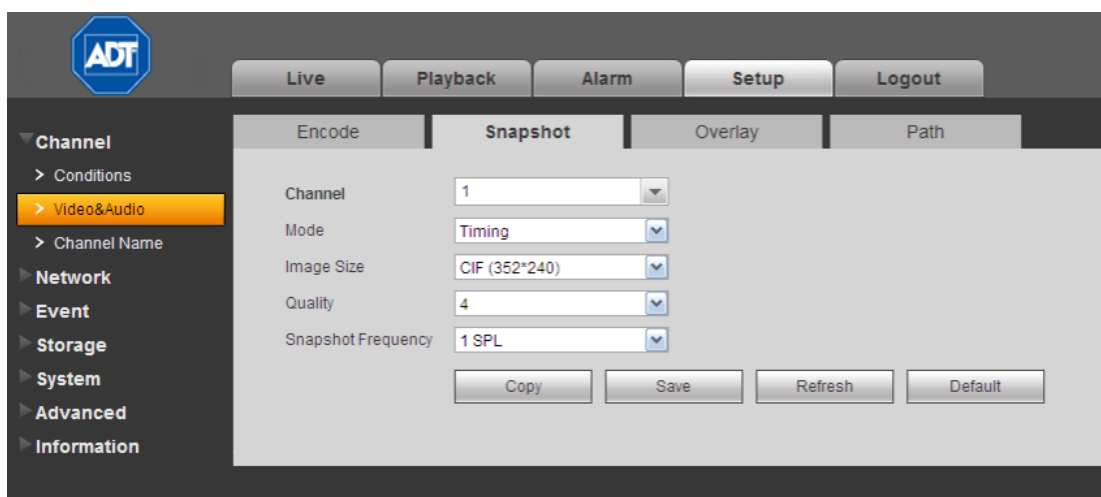

Figure 4-14

Refer to the following for detailed information. After making your selections, click **Save**.

Channel

Select a single channel number or **All** from the dropdown list.

Mode

Select **Timing** (schedule) or **Event** (activation). Timing snapshot is valid during the specified period you set. Activation snapshot is only valid for a motion detection alarm or a camera masking alarm.

Image Size

This is the same as the resolution of the Main Stream. Select from D1, HD1, 2CIF, CIF or QCIF.

Quality

Set the image quality. Select from 1–6, with 6 being the highest.

Frequency

This sets snapshot frequency, ranging from 1s to 7s.

Buttons

- Copy.** Click this button to copy the current channel's setup to other channels.
- Save.** Click to save the changes you have made.
- Refresh.** Click to refresh the web connection.
- Default.** Click to return settings on this page to their default values.

Video Overlay

The Overlay screen provides options to be displayed over the video screen.

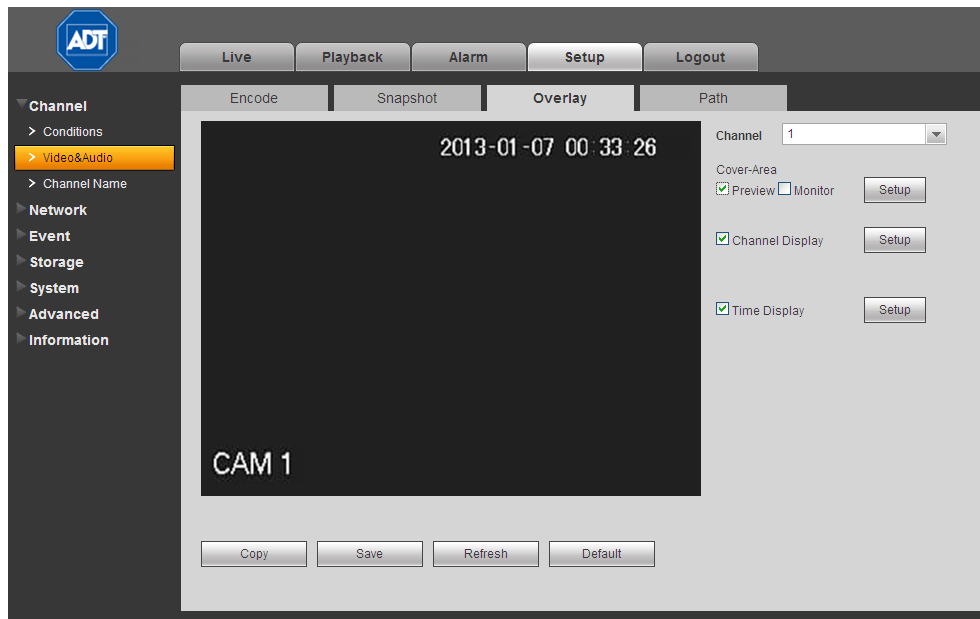

Figure 4-15

Refer to the following for detailed information. After making your selections, click **Save**.

Channel

Select a single channel number from the dropdown list.

Cover-Area (Privacy Mask)

This setting enables a privacy mask for the specified video in the Preview (live) or Monitor (playback) video. The system supports a maximum of 4 privacy mask zones

To enable this feature in live mode, check the Preview box; or to enable in the recorded file for playback, check the Monitor box, and then click the **Setup** button.

Channel Display

Enable this function to overlay the channel name in the video window. The name appears in the live video or the playback video.

Click the **Setup** button. A field appears for you to enter the desired name. Use the mouse to drag the Channel Name to the desired position.

Time Display

Enable this function to overlay the time stamp in the video window. The name appears in the live video or the playback video.



Click the **Setup** button. Use the mouse to drag the Time icon to the desired position.

Buttons

- Copy.** Click this button to copy the current channel's setup to other channels.
- Save.** Click to save the changes you have made.
- Refresh.** Click to refresh the web connection.
- Default.** Click to return settings on this page to their default values.

Path

Use the Path screen to set the location if where snapshot images and video recording files are stored.

1. Click the **Browse** button to set the saved path for the snapshot image ( on the Live screen) and the recording storage path ( on the Live screen).
The default path is *C:\PictureDownload* and *C:\RecordDownload*.
2. Click the **Save** button to save the current setup.

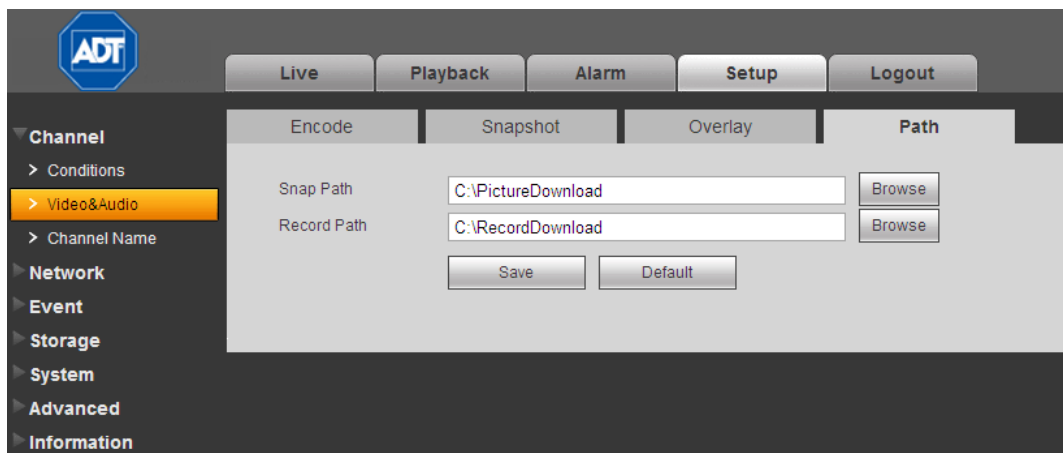

Figure 4-16

4.6.1.3 Channel Name

Use this screen to set a name for the camera on each channel. Click the **Save** button to store your settings.

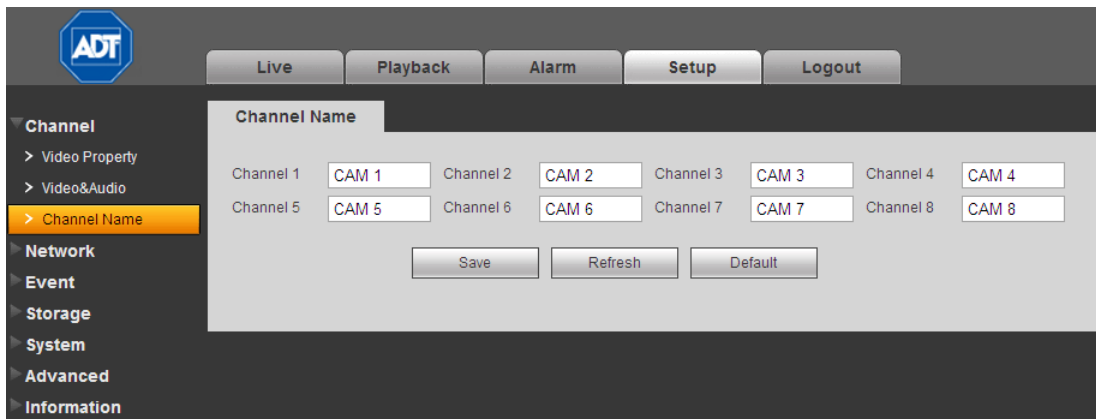

Figure 4-17

4.6.2 Network

4.6.2.1 TCP/IP

The TCP/IP screen is for setting up network parameters.

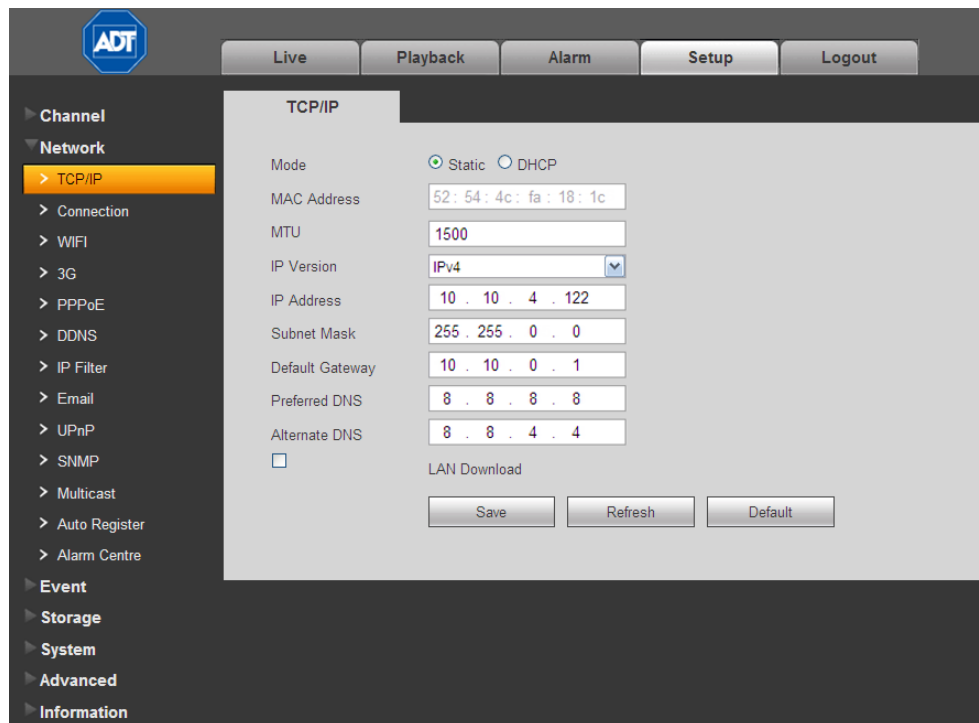

Figure 4-18

Refer to the following for detailed information.

Mode

Select between two modes: **Static** or **DHCP**.

MAC Address

Displays the host MAC address.

MTU

Displays the Maximum Transmission Unit (MTU) value of the network adapter. The value ranges from 1280-7200 bytes. The default setup is 1500 bytes.

MTU modification can affect current network service and may result in a reboot of the network adapter. When you change the MTU setup, a pop up dialog box appears for you to confirm the setup. Click the OK button to confirm the reboot or click Cancel to terminate the modification. Before the modification, check the MTU of the gateway. The MTU of the DVR must be the same as or lower than the MTU of the gateway. In this way, you can reduce packets and enhance network transmission efficiency.

The following MTU values are for reference only.

- **1500:** This is the Ethernet information packet maximum value and the default. It is the typical setup when there is no PPPoE or VPN. It is also the default setup of some routers, switches and network adapters.
- **1492:** Recommended value for PPPoE.
- **1468:** Recommended value for DHCP.

IP Version

Select the IP version: Only IPV4 is valid at his time.

IP Address

Use the keyboard to input the IP address and then set the corresponding Subnet Mask and the Default Gateway.

Preferred DNS

Displays the DNS IP address.

Alternate DNS

Displays the alternate DNS IP address.

LAN Download

If enabled. The system can process the downloaded data, resulting in increased download speeds of 1.5X to 2.0X.

Note:

- When you select the DHCP mode to auto search, the IP Address, Subnet Mask and Gateway fields are removed.
- If you select **Static** mode, you manually set the IP Address, Subnet Mask and Gateway.
- If you select **DHCP** mode, you can view the IP Address, Subnet Mask and Gateway from the DHCP.
- If you switch from the **DHCP** mode to the **Static** mode, you must reset the IP parameters.
- IP Address, Subnet Mask, Gateway and DHCP are read-only when the PPPoE dial is OK.

4.6.2.2 Connection

The connection screen is shown below in Figure 4-19.

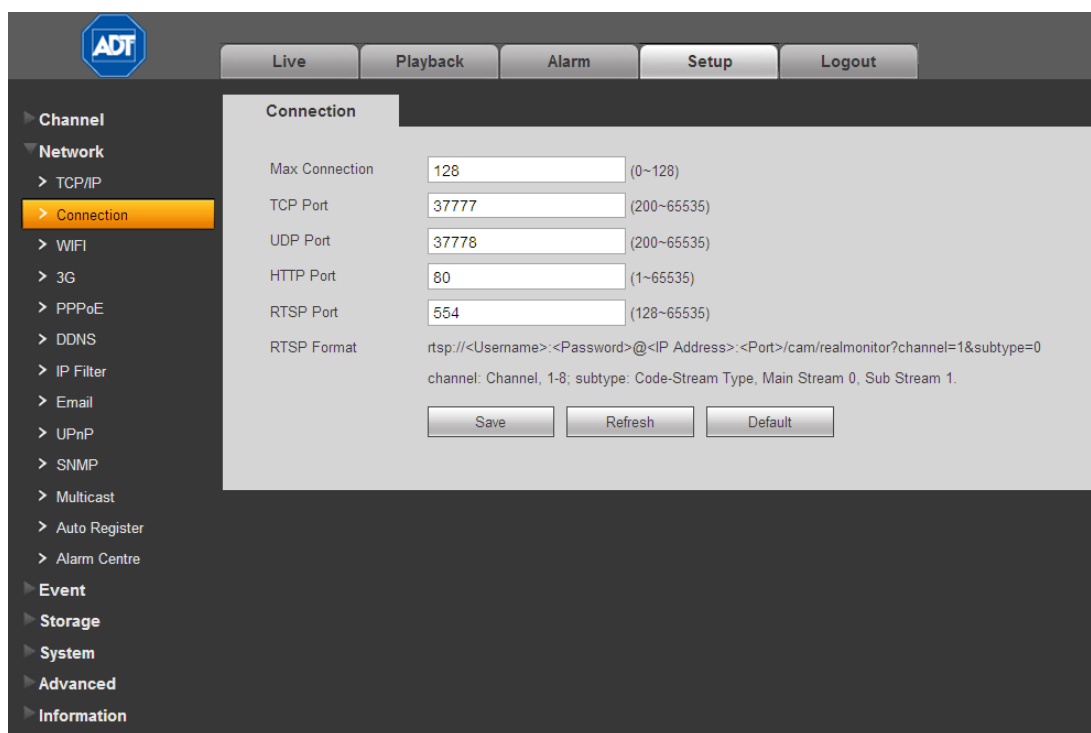

Figure 4-19

Refer to the following for detailed information.

Max connection. This setting is the maximum allowed web connections for one device. The value ranges from 1 to 20. The default setup is 10.

TCP Port. The default value is 37777. You can input the actual port number.

UDP Port. The default value is 37778. You can input the actual port number.

HTTP Port. The default value is 80. You can input the actual port number.

RTSP Port. The default value is 554.

4.6.2.3 WIFI

This feature is not supported by ADT at this time.

4.6.2.4 3G

This feature is not supported by ADT at this time.

4.6.2.5 PPPoE

To set up PPPoE:

1. Check the **Enable** box to enable the PPPoE feature.
2. Input the PPPoE User Name and Password you get from the Internet Service Provider.
3. Click **Save**.
4. Reboot the device.

The DVR connects to the internet via PPPoE after reboot. You can get the IP address from the WAN in the IP address column.

Note: You must use the previous IP address in the LAN to login the device. Go to the IP address item to see the current device information. You can access the client end via this new address.

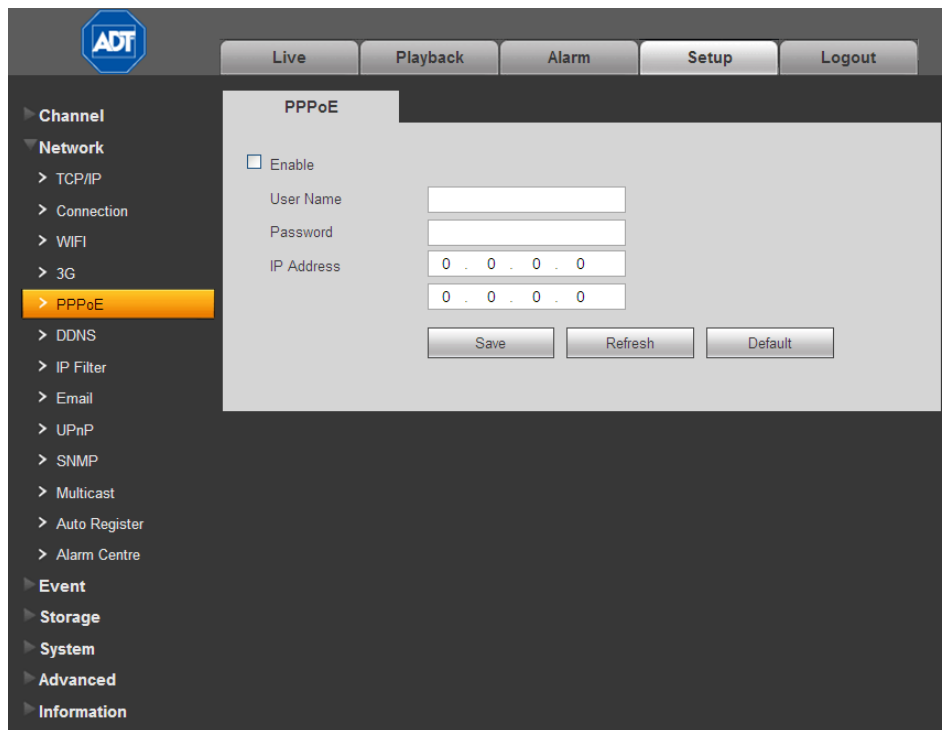

Figure 4-20

4.6.2.6 DDNS

The DDNS page is used to connect various servers so that you can access the DVR system via the server.

Requirements: You must have a PC with a fixed IP and DDNS software running. In other words, this PC is a DNS (domain name server).

To set up DDNS:

1. Go to the corresponding service website to apply for a domain name.
2. Access the system via the domain. It works even if your IP address has changed.
3. Select **DDNS** from the dropdown list.

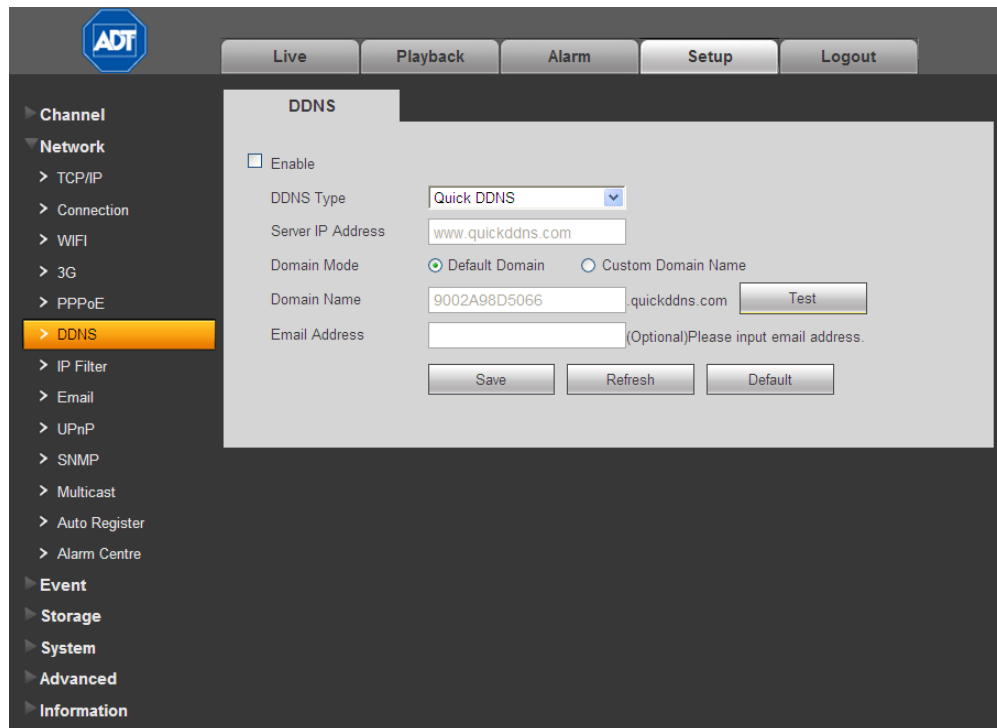
**Figure 4-21**

Refer to the following for detailed information.

Enable. Check the box to enable this function.

Server Type. Select the DDNS protocol from the dropdown list and then enable DDNS function

Server IP. DDNS server IP address

Server Port. DDNS server port.

Domain Name. Your self-defined domain name.

User. The user name you input to log in the server.

Password. The password you input to log in the server.

Update period. The device sends out a live signal to the server regularly. This parameter sets the interval value between the device and DDNS server.

Quick DDNS and Client End Introduction

1. Background Introduction

The device IP is not fixed if you use ADSL to log into the network. The DDNS function enables you to access the DVR via the registered domain name. Besides the general DDNS, the quick DDNS works with the device from the manufacturer to add the extension function.

2. Function Introduction

The quick DDNS client has the same function as other DDNS client end. It initiates the bonding of the domain name and the IP address. Right now, current DDNS server is for our own devices only. You must refresh the bonding relationship of the domain and the IP regularly. There is no user name, password or the ID registration on the server. At the same time, each device has a default domain name (Generated by MAC address) for your option. You can also use customized valid domain name (has not registered).

3. Operation

Before you use Quick DDNS, you must enable this service and set proper server address, port value and domain name.

- Server address: www.quickddns.com
- Port number: 80
- Domain name: There are two modes: Default domain name and customized domain name.

Except default domain name registration, you can also use customized domain name (You can input your self-defined domain name.) After successful registration, you can use domain name to login installed of the device IP.

User Name. This item is optional. You can input your commonly used email address.

IMPORTANT:

- Do not register frequently. The interval between two registrations must be more than 60 seconds.
- The system may take back the domain name that is idle for one year. You can get a notification email before the cancel operation if your email address setup is OK.

4.6.2.7 IP Filter

After you enabled trusted sites function, only the IP listed below can access current DVR. If you enable blocked sites function, the following listed IP addresses cannot access current DVR.

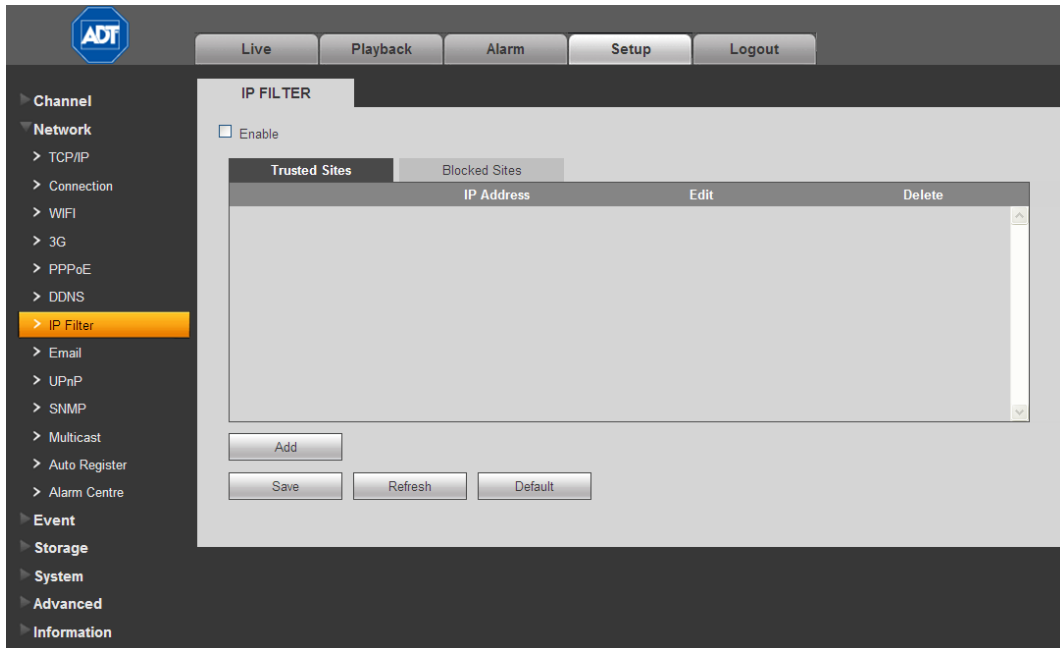

Figure 4-22

4.6.2.8 Email

The Email screen is used to set up email alerts, if you have set them up for sending out an alert in the event of a triggered alarm.

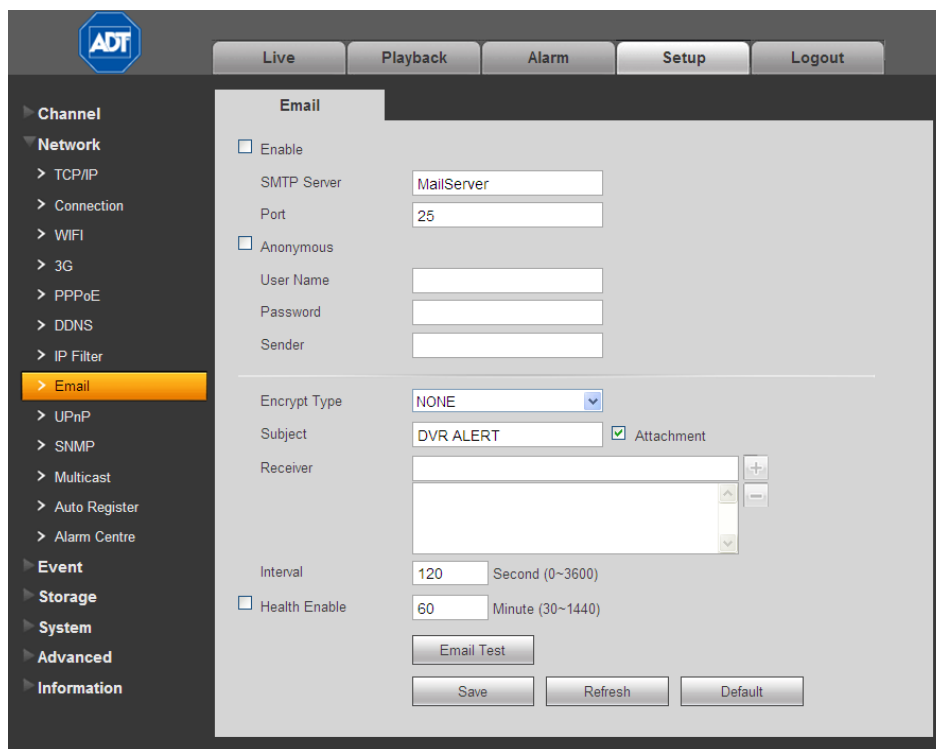

Figure 4-23

Refer to the following for detailed information.

Enable

Check this box to enable email function.

SMTP Server

Input the server address and then enable this function.

Port

Default value is 25.

Anonymous

Enable for servers that support the anonymity function, which allows you to automatically login anonymously. If enabled, you do not need to input the user name, password or the sender information.

User Name

The user name of the sender email account.

Password

The password of sender email account.

Sender

Sender email address.

Authentication (Encryption mode)

Select SSL, TLS or NONE.

Subject

Input email subject here.

Attachment

Check the box to send out the email of the snapshot picture.

Receiver

Enter the destination (receiver's) email address (maximum of three addresses. This supports SSL and TLS email boxes.

Interval

The send interval ranges from 0 to 3600 seconds. 0 means there is no interval.

The system will not send out the email immediately when the alarm occurs. When the Motion Detection or the Abnormality event activates the email, the system sends out the email according to the interval you have specified here. This function is very useful when there are too many emails activated by the Abnormality events, which may result in heavy load for the email server.

Health Mail Enable

Check the box to enable this function.

Update Period (Interval)

This function enables the system to send out a test email for checking the connection. Check the box to enable this function and then set the corresponding interval. The system can send out the email regularly as you set here.

Email Test

The system will automatically send out an email once to verify that the connection is OK. Save the email setup information before performing the email test.

4.6.2.9 UPnP

This feature enables you to establish the mapping relationship between the LAN and the public network. Here you can also add, modify or remove UPnP item. See Figure 4-24.

1. In Windows, navigate to *Start > Control Panel > Add or remove programs*.
2. Click Add/Remove Windows Components and then select Network Services from the Windows Components Wizard.
3. Click the **Details** button and then check **Internet Gateway Device Discovery and Control client** and **UPnP User Interface**.
4. Click **OK** to begin installation.
5. Enable UPnP from the Web. If your UPnP is enabled in the Windows OS, the DVR can auto detect it via My Network Places.

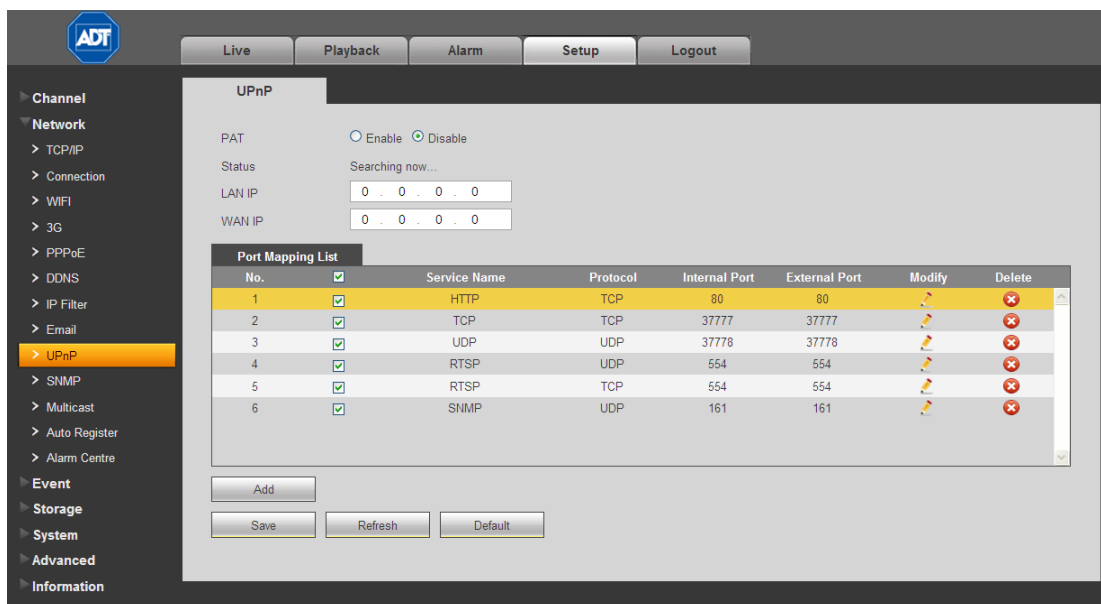

Figure 4-24

4.6.2.10 SNMP

The SNMP screen enables the communication between the network management work station software and the proxy of the managed device.

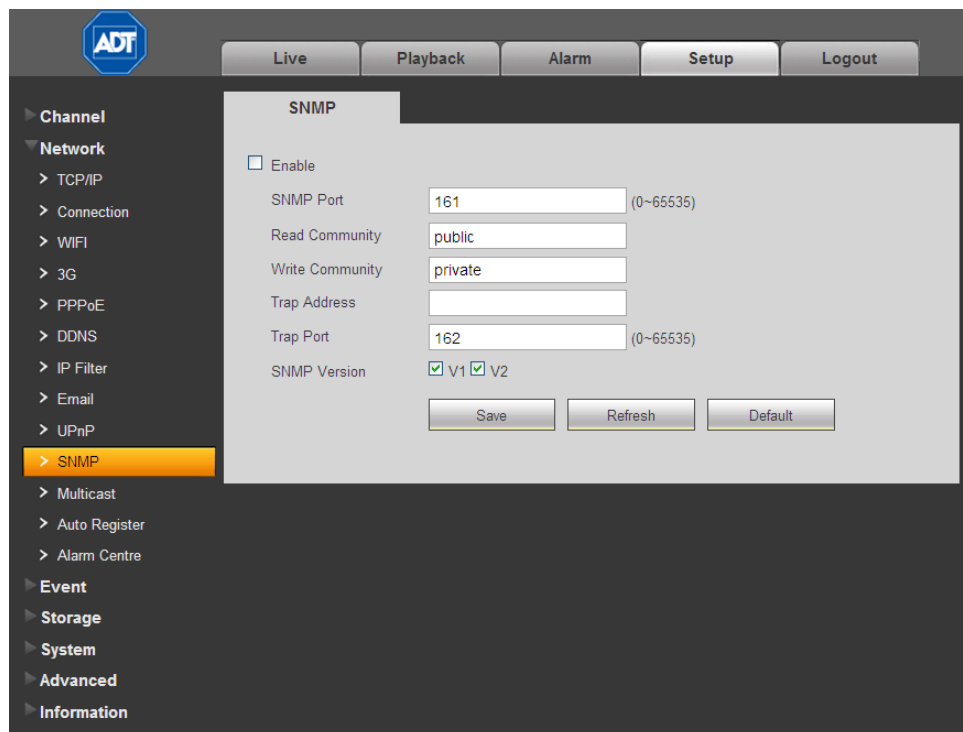

Figure 4-25

Refer to the following for detailed information.

SNMP Port

The listening port of the proxy program of the device. It is a UDP port not a TCP port. The value ranges from 1 to 65535. The default value is 161.

Read Community

This is a string. It is a command between the manage process and the proxy process. It defines the authentication, access control and the management relationship between one proxy and one group of the managers. Make sure that the device and the proxy are the same.

The read community will read all the objects the SNMP supported in the specified name. The default setup is public.

Write Community

This is a string. It is a command between the manage process and the proxy process. It defined the authentication, access control and the management relationship between one proxy and one group of the managers. Make sure that the device and the proxy are the same.

The read community will read/write/access all the objects the SNMP supported in the specified name. The default setup is **write**.

Trap Address

The destination address of the Trap information from the proxy program of the device.

Trap Port

The destination port of the Trap information from the proxy program of the device. It is for the gateway device and the client end PC in the LAN to exchange the information. It is a non-protocol connection port. It has no effect on the network applications. It is a UDP port not TCP port. The value ranges from 1 to 165535. The default value is 162.

SNMP Version

If you check V1, the system only processes the information of V1.

If you check V2, the system only processes the information of V2.

SNMP V3 requires account security verification for the server to connect to the device. If you select V3, the user name and password fields appear and the V1 and V2 are not selectable.

4.6.2.11 Multicast

Multicast is a transmission mode for data packets. Multicast sends IP datagrams to a group of receivers in a single transmission. When there are multiple hosts to receive the same data packet, multicast is the best option to reduce the bandwidth and the CPU load. The source host can send out just one data packet. This function also depends on the relationship of the group member and the group.

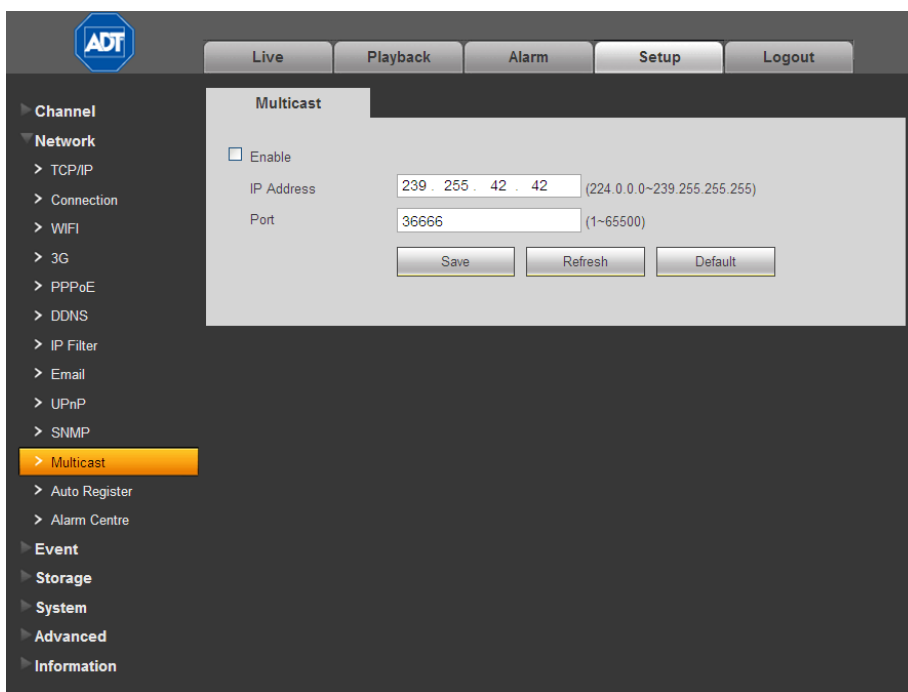

Figure 4-26

4.6.2.12 Auto Register

The Auto Register page is shown below.

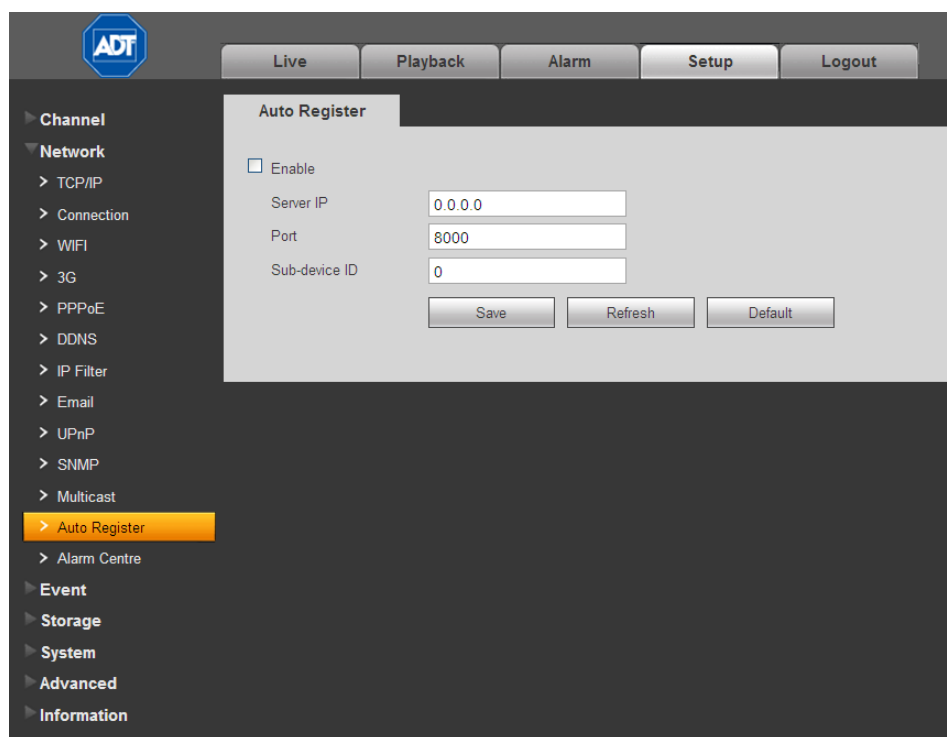

Figure 4-27

This function enables the device to automatically register to the proxy you have specified. In this way you can use the client end to access the DVR via the proxy. In the network service, the device supports a server address of IPv4 protocol.

To use the Auto Register function:

1. Set the proxy server address, port and sub-device name at the device end.
2. Enable the Auto Register function. The device automatically registers to the proxy server.

IMPORTANT: Do not input a network default port such as the TCP port number.

The proxy server software is developed from the SDK. Open the software and input the global setup. Make sure the auto connection port here is the same as the port you set in the previous step.

3. Now add the device. Do not input default port number such as the TCP port in the mapping port number. The device ID used here must be the same as the ID you input in Figure 3-24.
4. Click the **Add** button to complete the setup.
5. Boot up the proxy server.

When you the network status is **Y**, the registration is OK. You can view the proxy server when the device is online.

IMPORTANT: The server IP address can also be the domain but you must register a domain name before you run the proxy device server.

4.6.3 Event

4.6.3.1 Video Detect

The Video Detect section is used for setting up the type of events for which you want to trigger a response, such as triggering an alarm, sending an email or taking a snapshot. There are three detection types that you can set as an event:

- Motion Detect
- Video Loss
- Camera Masking

Motion Detect

Use the Motion Detect screen for setting up a Motion Detection event to trigger an alarm and initiate recording.

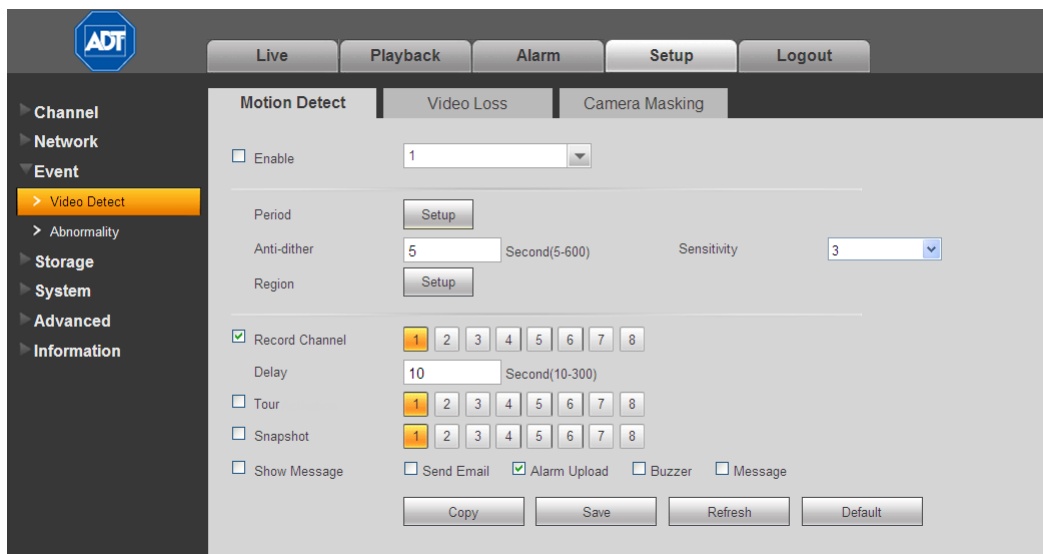

Figure 4-28

The following describes the Detect window:

Enable

Check the box to enable the motion detection function. Then select a channel to be enabled from the dropdown list.

Period

This feature activates the Motion Detection function in the specified time periods.

To set the Motion Detect period:

1. Click the **Setup** button.
2. In the resulting setup dialog (see Figure 4-29), select a day of the week from the drop-down menu.
3. For the selected day, check the box for one of the six 24-hour time periods and set the corresponding recording range.
4. Repeat for other time periods if desired.
5. Click **Save**. The system reverts to the Motion Detect page.

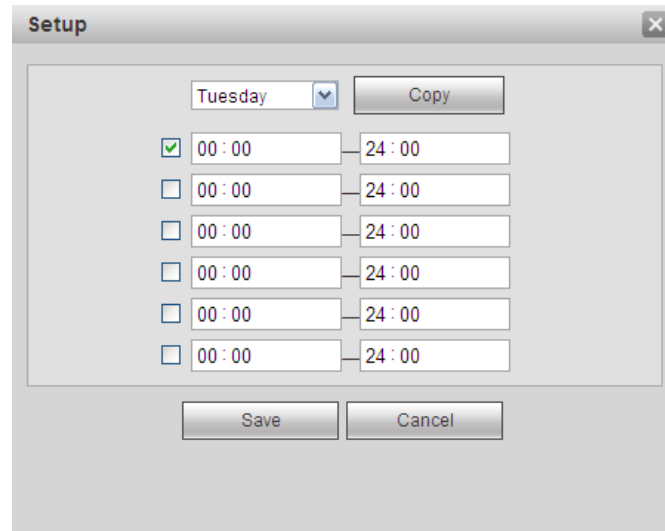
**Figure 4-29****Note:**

- Set the Motion Detect record period.
- Navigate to *Storage > Schedule* to set the current channel as a scheduled recording.

Anti-dither

This feature sets a delay period before triggering the next Motion Detection event, to avoid re-triggering on the same event. The delay period begins when the current motion detection event has ended. The system only stores one event during the anti-dither period. The value ranges from 5s to 600s.

Sensitivity

There are six levels. The sixth level has the highest sensitivity.

Region

Click the **Select** button to set Motion Detection zone. There are 396(PAL)/330(NTSC) small zones. The blue zone is the motion detection zone; the clear zone is the disarmed zone. The system can only detect motion detect signal from the armed region.

To set the Motion Detection Region:

1. Click the **Setup** button. A single screen display appears with a grid and semi-transparent overlay.
The blue zone is the armed (motion detection) zone; the clear zone is the disarmed zone. The system only detects motion in the blue armed region. The default setup is the entire screen (all blue).
2. Drag the mouse to set the motion detection zone. The selected area no longer shows the overlay.
3. Click **Save**.

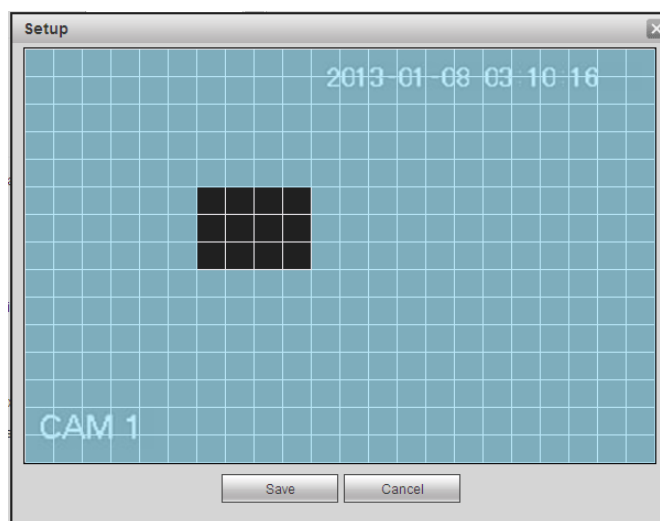
**Figure 4-30** **Record Channel**

Check the box to enable, and then click the buttons for the channels that you want recorded when the event is triggered. The selected channels are highlighted.

Delay

To avoid rerecording the same event, enter the number of seconds to wait after the event has ended before a new recording can begin. This value ranges from 10s to 300s.

 Tour

When an alarm occurs, this feature presents an alternating display (much like a slideshow) of the channel(s) you set to record.

Check the box to enable, and then click the buttons for the channels that you want included in the tour. The selected channels are highlighted.

 Snapshot

When an alarm occurs, this feature takes a still image of the channel(s) you set to record.

Check the box to enable, and then click the buttons for the channels that you want included in the snapshot. The selected channels are highlighted.

Checkboxes

- Show Message.** If enabled, a pop up alarm message appears in the local host screen.
- Send Email.** If enabled, an email alert is sent to you when an alarm occurs.
- Alarm Upload.** If enabled, the alarm signal is uploaded to the network.
- Buzzer.** If enabled, a buzzer sounds when an alarm occurs.
- Message.** If a 3G network is connected, a message is sent when a motion detection event occurs. *Note: This feature is not supported by ADT at this time.*

Video Loss

Use the Video Loss screen for triggering up alarms when no video signal is detected.

Note: Video Loss does not support anti-dither, sensitivity, or region setup.

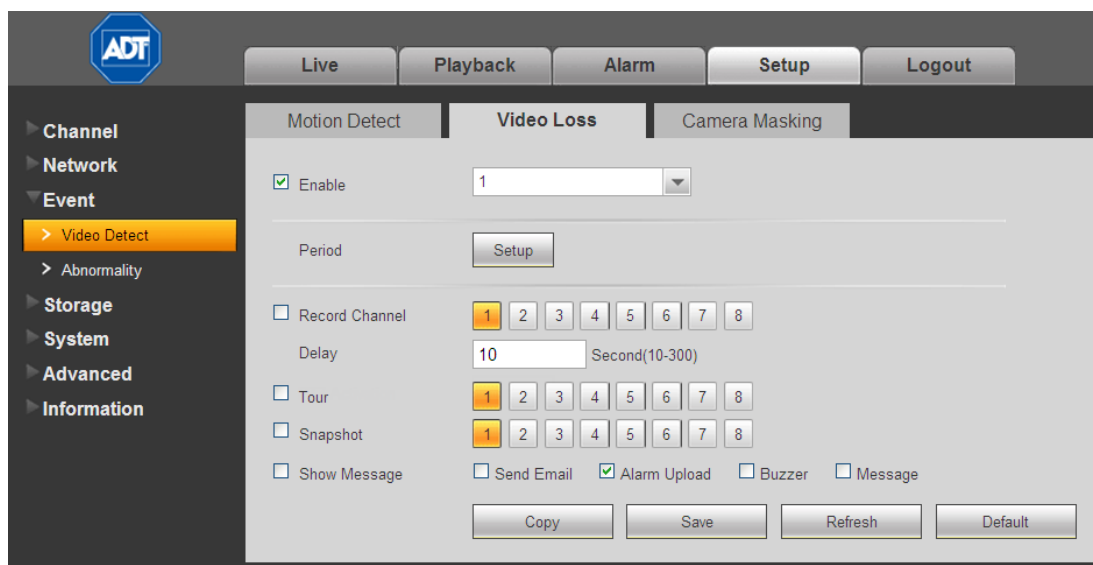

Figure 4-31

The following describes the Video Loss window:

Enable

Check the box to enable the Video Loss function. Then select a channel to be enabled from the dropdown list.

Period

This feature activates the Video Loss function in the specified time periods.

To set the Video Loss period:

1. Click the Setup button.
2. In the resulting setup dialog, select a day of the week from the drop-down menu.
3. For the selected day, check the box for one of the six 24-hour time periods and set the corresponding recording range.

4. Repeat for other time periods if desired.
5. Click **Save**. The system reverts to the Video Loss page.

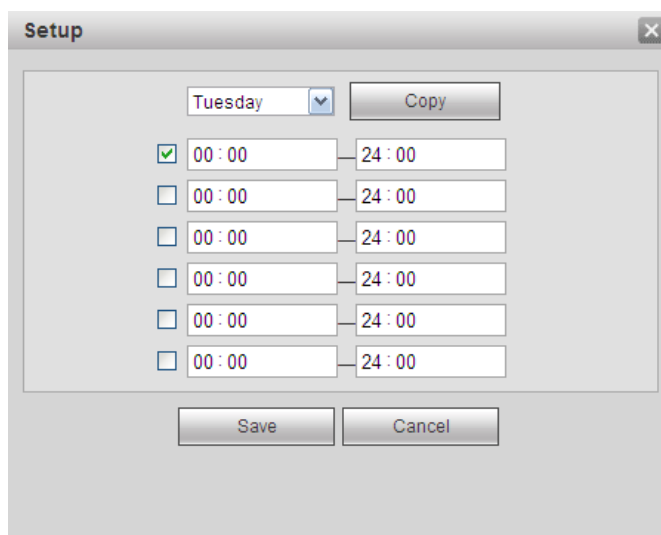

Figure 4-32

Record Channel

Check the box to enable, and then click the buttons for the channels that you want recorded when the event is triggered. The selected channels are highlighted.

Delay

To avoid rerecording the same event, enter the number of seconds to wait after the event has ended before a new recording can begin. This value ranges from 10s to 300s.

Tour

When an alarm occurs, this feature presents an alternating display (much like a slideshow) of the channel(s) you set to record.

Check the box to enable, and then click the buttons for the channels that you want included in the tour. The selected channels are highlighted.

Snapshot

When an alarm occurs, this feature takes a still image of the channel(s) you set to record.

Check the box to enable, and then click the buttons for the channels that you want included in the snapshot. The selected channels are highlighted.

Checkboxes

- Show Message.** If enabled, a pop up alarm message appears in the local host screen.
- Send Email.** If enabled, an email alert is sent to you when an alarm occurs.
- Alarm Upload.** If enabled, the alarm signal is uploaded to the network.
- Buzzer.** If enabled, a buzzer sounds when an alarm occurs.
- Message.** If a 3G network is connected, a message is sent when a motion detection event occurs. *Note: This feature is not supported by ADT at this time.*

Camera Masking

The Camera Masking feature alerts you when someone maliciously masks the lens, or the output video is in monochrome due to a change in ambient light.

Note: Camera masking does not support anti-dither, sensitivity, or region setup.

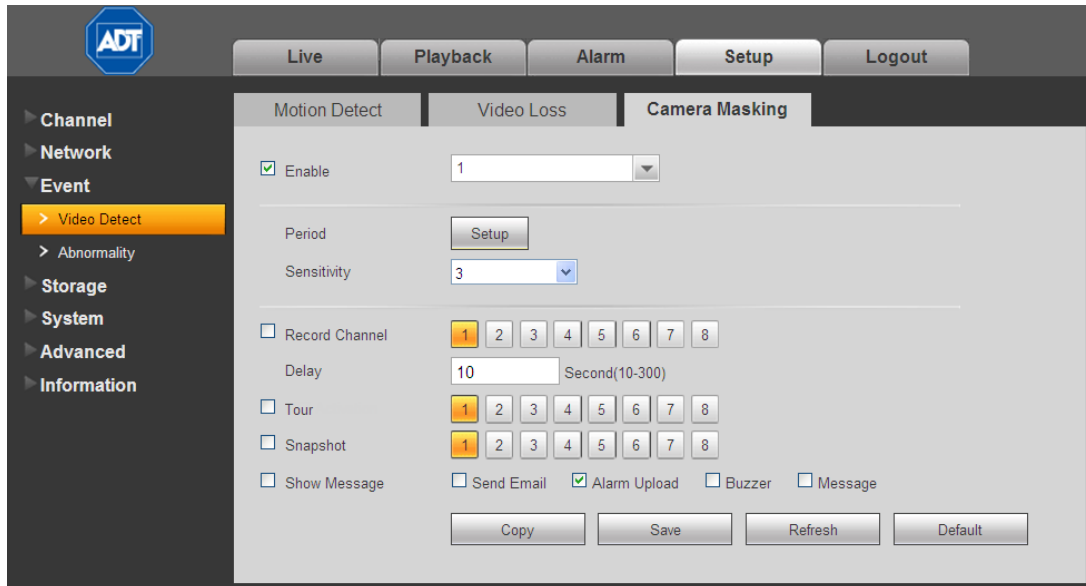

Figure 4-33

Enable

Check the box to enable the Camera masking function. Then select a channel from the dropdown list.

Period

This feature activates the Camera Masking function for the specified periods.

To set the Camera Masking period:

1. Click the **Setup** button.
2. In the resulting setup dialog, select a day of the week from the drop-down menu.
3. For the selected day, check the box for one of the six 24-hour time periods and set the corresponding recording range.
4. Repeat for other time periods if desired.
5. Click **Save**. The system reverts to the Camera Masking page.

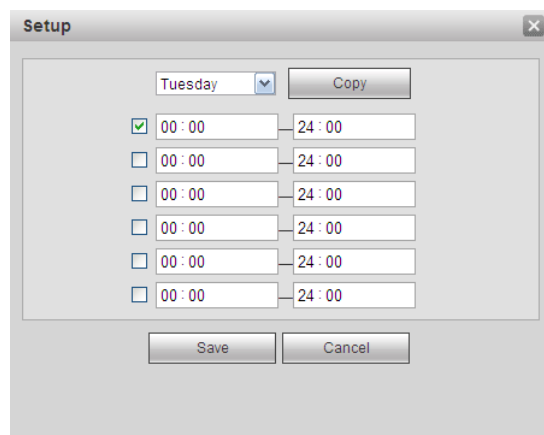

Figure 4-34

Sensitivity

There are six levels. The sixth level has the highest sensitivity.

Record Channel

The system automatically activates to record selected channels once a motion detection alarm occurs. Check the box to enable, and then click the buttons for the channels that you want recorded. The selected channels are highlighted.

Delay

To avoid rerecording the same event, enter the number of seconds to wait after the event has ended before a new recording can begin. This value ranges from 10s to 300s.

Tour

When an alarm occurs, this feature presents an alternating display (much like a slideshow) of the channel(s) you set to record.

Check the box to enable, and then click the buttons for the channels that you want included in the tour. The selected channels are highlighted.

Snapshot

When an alarm occurs, this feature takes a still image of the channel(s) you set to record.

Check the box to enable, and then click the buttons for the channels that you want included in the snapshot. The selected channels are highlighted.

Checkboxes

- Show Message.** If enabled, a pop up alarm message appears in the local host screen.
- Send Email.** If enabled, an email alert is sent to you when an alarm occurs.
- Alarm Upload.** If enabled, the alarm signal is uploaded to the network.
- Buzzer.** If enabled, a buzzer sounds when an alarm occurs.
- Message.** If a 3G network is connected, a message is sent when a camera masking event occurs. *Note: This feature is not supported by ADT at this time.*

4.6.3.2 Abnormality

This area provides you with the opportunity to set notifications for six possible anomalous status conditions: No Disk, Disk Error, No Disk Space, Network Disconnection, IP Conflict and MAC Conflict.

No Disk

To enable notification(s) when no disk drive is detected:

1. Check the **Enable** box.
2. Check the box associated with the desired notifications:
 - Show Message.** If enabled, a pop up alarm message appears in the local host screen.
 - Send Email.** If enabled, an email alert is sent to you when an alarm occurs.
 - Alarm Upload.** If enabled, the alarm signal is uploaded to the network.
 - Buzzer.** If enabled, a buzzer sounds when an alarm occurs.
 - Message.** If a 3G network is connected, a message is sent when the anomalous occurs.

Note: This feature is not supported by ADT at this time.

3. Click **Save**.

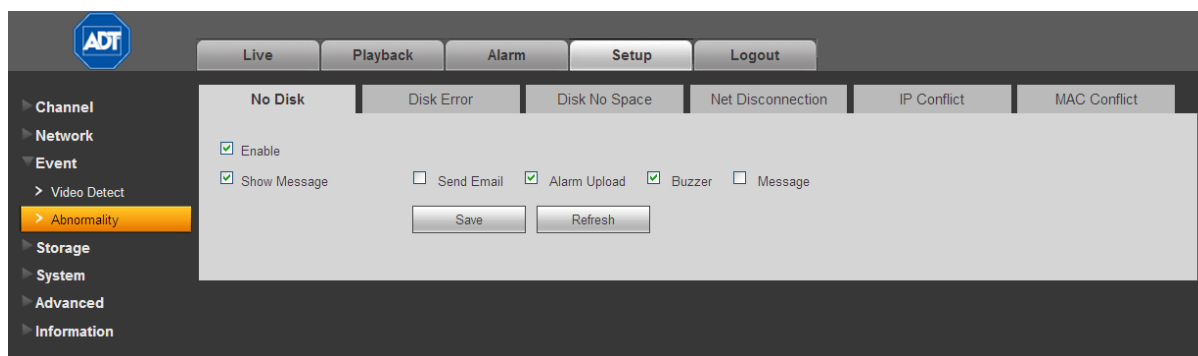

Figure 4-35

Disk Error

To enable notification(s) when a disk error is detected:

1. Check the **Enable** box.
2. Check the box associated with the desired notifications:
 - Show Message.** If enabled, a pop up alarm message appears in the local host screen.
 - Send Email.** If enabled, an email alert is sent to you when an alarm occurs.
 - Alarm Upload.** If enabled, the alarm signal is uploaded to the network.
 - Buzzer.** If enabled, a buzzer sounds when an alarm occurs.
 - Message.** If a 3G network is connected, a message is sent when the anomalous event occurs. *Note: This feature is not supported by ADT at this time.*
3. Click **Save**.

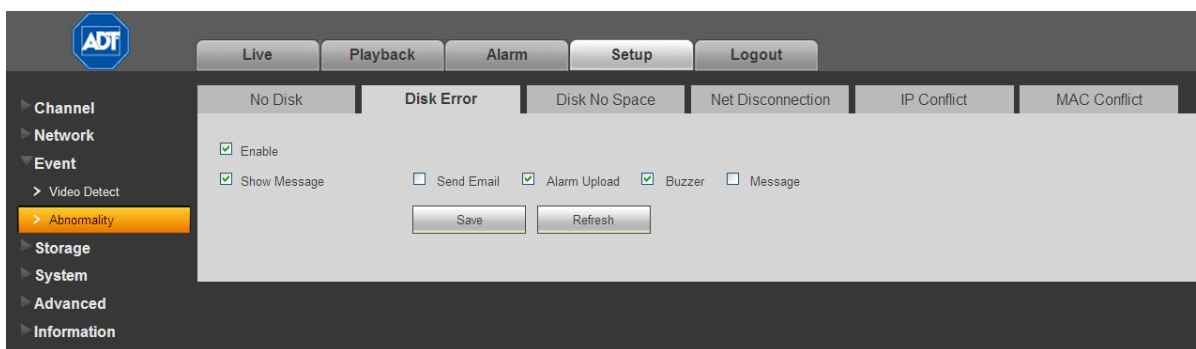

Figure 4-36

No Disk Space

To enable notification(s) when no disk space is detected:

1. Check the **Enable** box.
2. Enter the percentage of available disk space to be remaining for the alarm to be triggered.
3. Check the box associated with the desired notifications:
 - Show Message.** If enabled, a pop up alarm message appears in the local host screen.
 - Send Email.** If enabled, an email alert is sent to you when an alarm occurs.
 - Alarm Upload.** If enabled, the alarm signal is uploaded to the network.
 - Buzzer.** If enabled, a buzzer sounds when an alarm occurs.
 - Message.** If a 3G network is connected, a message is sent when the anomalous event occurs. *Note: This feature is not supported by ADT at this time.*
4. Click **Save**.

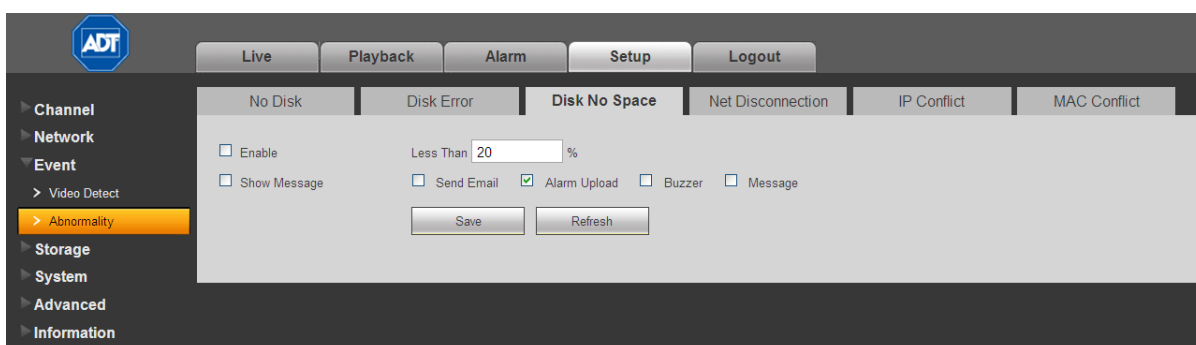

Figure 4-37

Network Disconnection

To enable notification(s) when the system becomes disconnected from the network:

1. Check the **Enable** box.
2. Check the box associated with the desired notifications:
 - Show Message.** If enabled, a pop up alarm message appears in the local host screen.
 - Send Email.** If enabled, an email alert is sent to you when an alarm occurs.

- Buzzer.** If enabled, a buzzer sounds when an alarm occurs.
 - Message.** If a 3G network is connected, a message is sent when the anomalous event occurs. *Note: This feature is not supported by ADT at this time.*
3. If desired, set up channels to record if this event occurs:
 - **Record Channel.** The system automatically activates to record selected channels once the error occurs. Check the box to enable, and the click the buttons for the channels that you want recorded. The selected channels are highlighted.
 - **Delay.** To avoid rerecording the same event, enter the number of seconds to wait after the event has ended before a new recording can begin. This value ranges from 10s to 300s.
 4. Click **Save**.

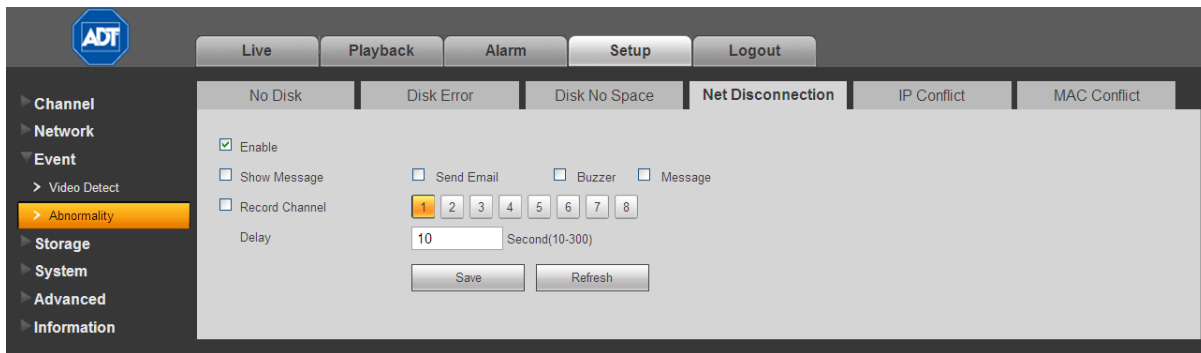

Figure 4-38

IP Conflict

To enable notification(s) when an IP conflict is detected:

1. Check the **Enable** box.
2. Check the box associated with the desired notifications:
 - Show Message.** If enabled, a pop up alarm message appears in the local host screen.
 - Send Email.** If enabled, an email alert is sent to you when an alarm occurs.
 - Buzzer.** If enabled, a buzzer sounds when an alarm occurs.
 - Message.** If a 3G network is connected, a message is sent when the anomalous event occurs. *Note: This feature is not supported by ADT at this time.*
3. Click **Save**.

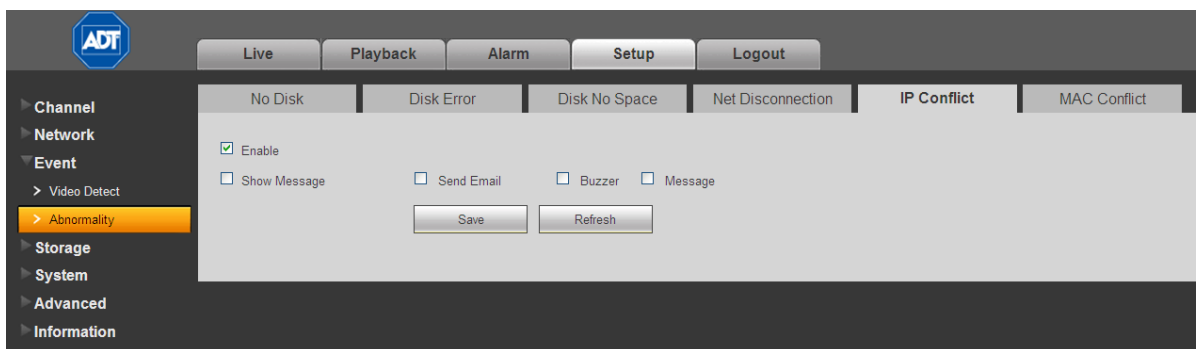

Figure 4-39

MAC Conflict

To enable notification(s) when a MAC conflict is detected:

1. Check the **Enable** box.
2. Check the box associated with the desired notifications:
 - Show Message**. If enabled, a pop up alarm message appears in the local host screen.
 - Send Email**. If enabled, an email alert is sent to you when an alarm occurs.
 - Buzzer**. If enabled, a buzzer sounds when an alarm occurs.
 - Message**. If a 3G network is connected, a message is sent when the anomalous event occurs. *Note: This feature is not supported by ADT at this time.*
3. Click **Save**.

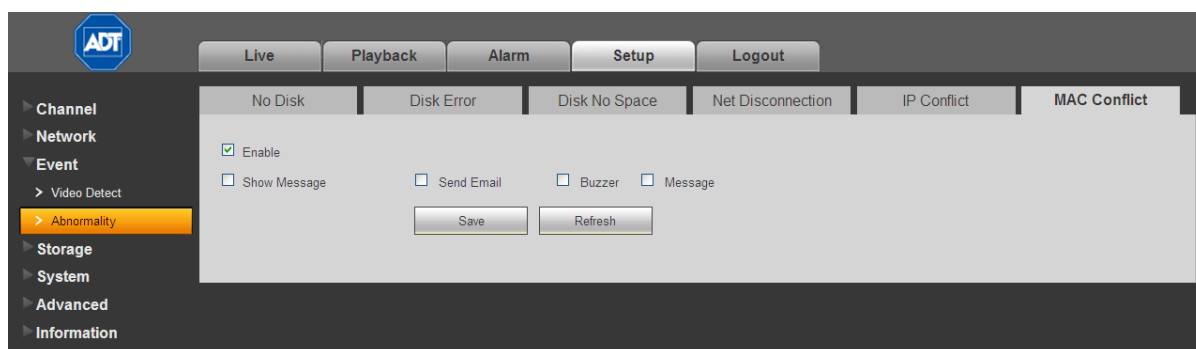

Figure 4-40

4.6.4 Storage

4.6.4.1 Schedule

In the Schedule screen you can add or remove scheduled recordings. See Figure 4-41.

There are four recording modes: Regular (auto), Motion Detect, Alarm and Motion Detect with Alarm. Make sure you have enabled the corresponding record mode in the *Setup > Storage > Conditions*.

You can view the current time period setup from the color bar.

- Green represents general recordings and snapshots
- Yellow represents motion detect recordings and snapshots
- Red represents alarm recordings and snapshots
- Blue represents motion detect with alarm recordings and snapshots

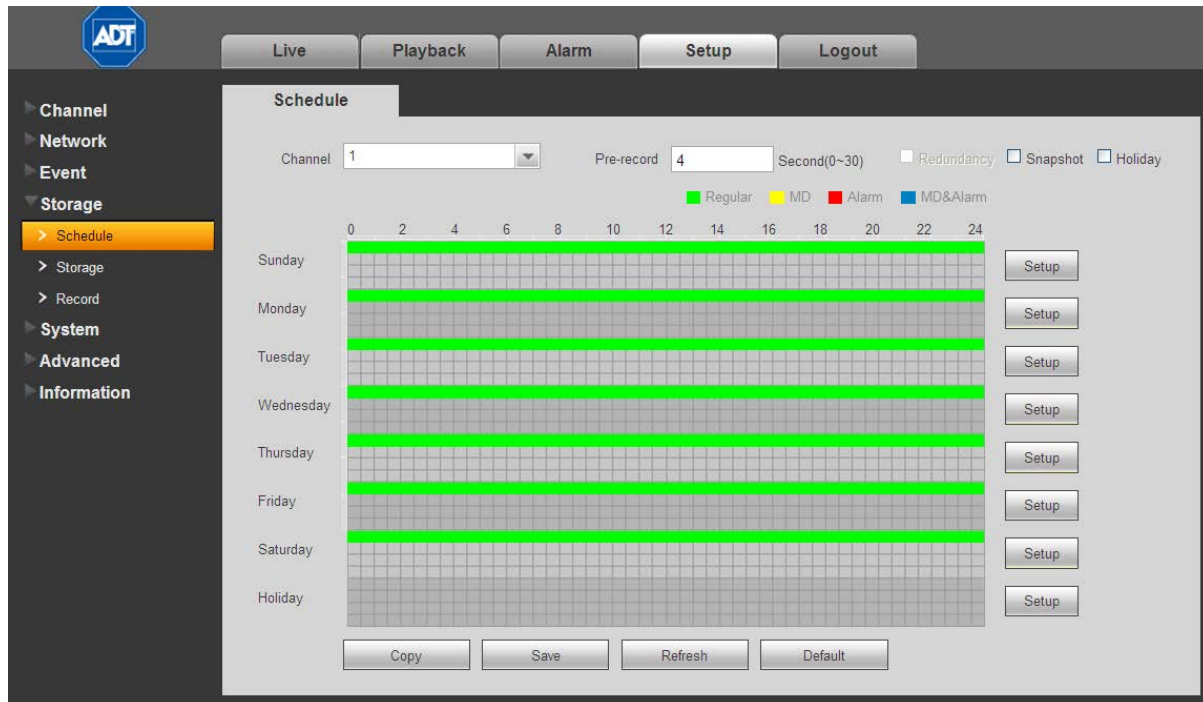

Figure 4-41

Options

- Channel.** Select the desired channel number. Select **All** if you want to set for all channels.
- Pre-record.** The system can pre-record the video before the event occurs into the file. The value ranges from 1 to 30 seconds depending on the bit stream.
- Redundancy.** Because it only supports one HDD, the redundancy function is not available for the DVR5 1xxC Series.
- Snapshot.** Check this box to enable the snapshot function.
- Holiday.** Click this box to enable holiday dates.

Buttons

Copy. Use this button to copy the current channel's setup to other channels.

To copy one channel's setup features to others:

1. After making all your selections in the Schedule page, click the **Copy** button. The channel selection dialog appears. The current channel name is grayed out.
2. Select the channel(s) to which you want to paste the same setup as for the current channel.
3. Click the **OK** button.

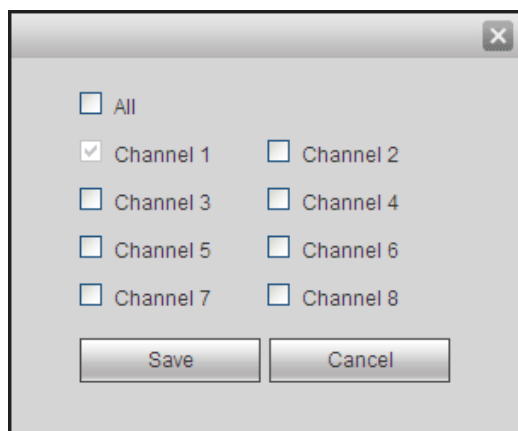

Figure 4-42

Save. Click to save the changes you have made.

Refresh. Click to refresh the web connection.

Default. Click to return settings on this page to their default values.

To use the Schedule feature:

1. Select the channel number you want to set up in the **Channel** dropdown menu.
2. Make selections from options above.
3. Click the **Setup** button for the desired day. In the resulting setup dialog are six 24-hour time periods.

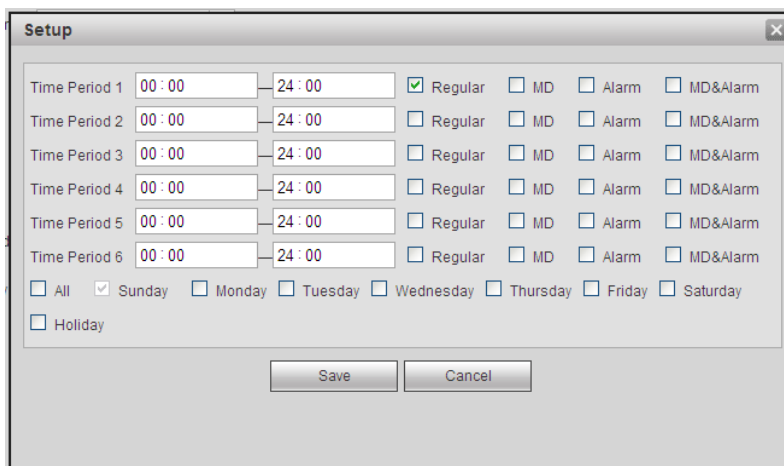

Figure 4-43

4. Set the corresponding recording range for each time period.
5. Repeat for other time periods if desired.
6. Check the box for the desired type of recordings: Regular, Motion Detect, Alarm or Motion Detect with Alarm.

7. If you would like for these same settings to be used for other days of the week, check the box(es) corresponding to those day(s).
8. Click **Save**. The system reverts to the Schedule page.
9. Click **Save**.

4.6.4.2 Storage

Local Storage

The Local Storage screen displays information for each HDD. You can also make changes in the HDD Operation dropdown menu: Set as read and write, read-only, or else format the hard drive.

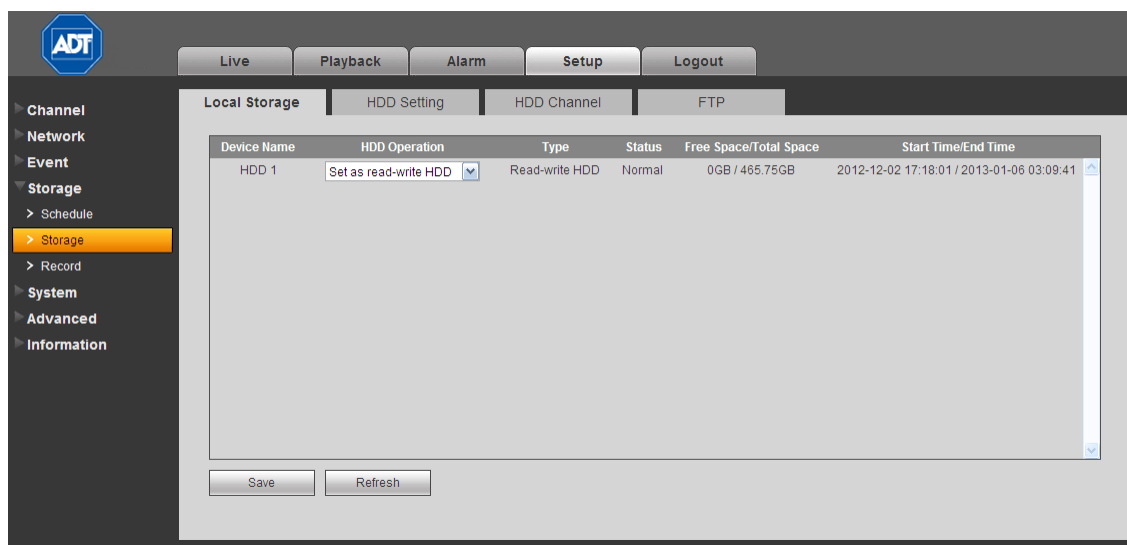

Figure 4-44

HDD Setting

Use the HDD Setting page to assign a hard drive to an HDD Group. See Figure 4-45.

To set the HDD to a Group:

1. In the row of the hard drive in question, use the drop-down to select the corresponding HDD Group number.
2. Click **Save**.

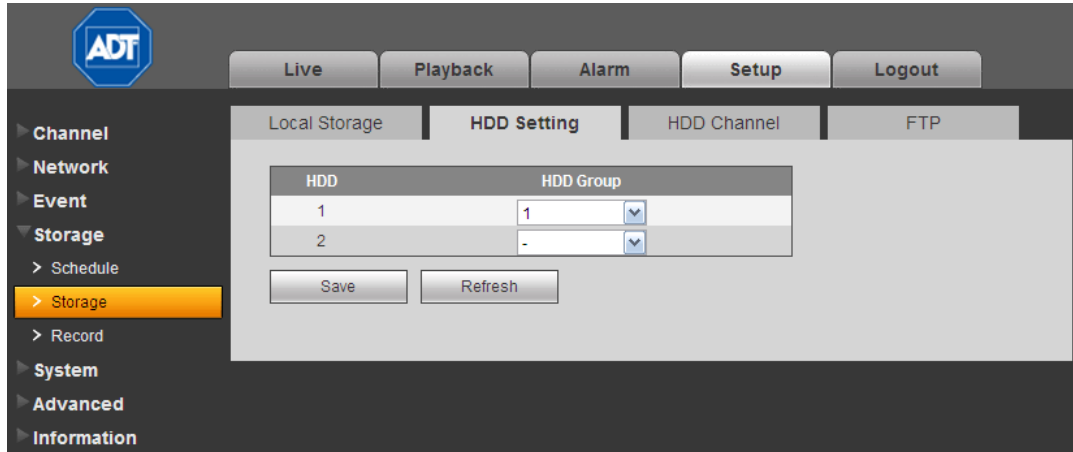

Figure 4-45

HDD Channel

Use the HDD Channel tab to assign a channel number to a channel group.

To assign the HDD Channel to a Group:

1. Locate the Channel number on the screen, and use the drop-down to select the corresponding HDD Group number for that channel.
2. Click **Save**.

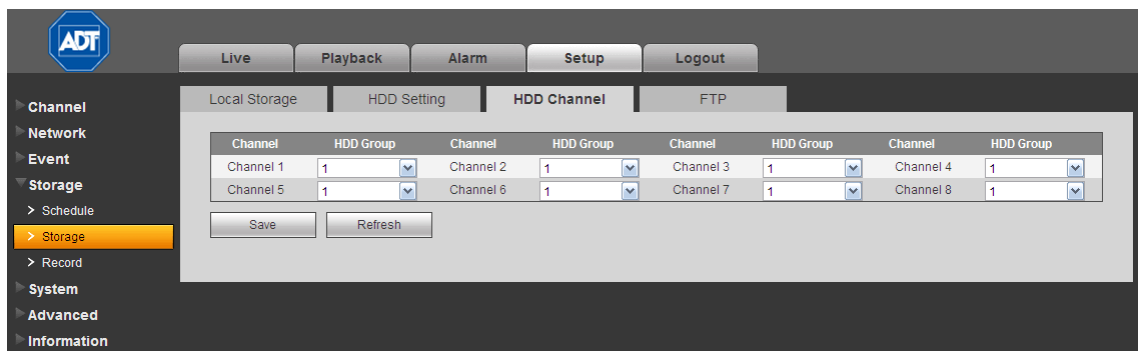

Figure 4-46

FTP

The FTP tab is used to save a recording or picture to HDD when the network is offline or malfunctioning. When the remote directory is not available, the system automatically creates folders according to the IP, time and channel set here.

Figure 4-47

To use the FTP feature:

1. Check the **Enable** box to activate the FTP function.
2. Input the FTP account information:
 - **FTP Server IP** number
 - **Port** number
 - **User Name** and **Password** you use to log into the FTP.
 - Optionally check the **Anonymous** box for servers that support the anonymity function, which allows you to automatically login anonymously. If enabled, you do not need to input the user name, password or the sender information.
3. Enter the **Remote Directory**.
4. Enter the upload **File Length**.
File length is upload file length. When this value is larger than the actual file length, the system uploads the whole file. When this value is smaller than the actual file length, the system only uploads the set length and automatically ignores the left section. When interval value is 0, system uploads all corresponding files.
5. Set the **Image Upload Interval**.

6. Use the drop-down menu to select the upload file **Channel**.
7. Use the drop-down menu to select the day.
8. Set the **Time Period** and type of event: **Alarm**, **MD** (motion detection) or **Regular**.
9. Click **Save**.

4.6.4.3 Recording

This feature enables you to manually override the automatic record settings.

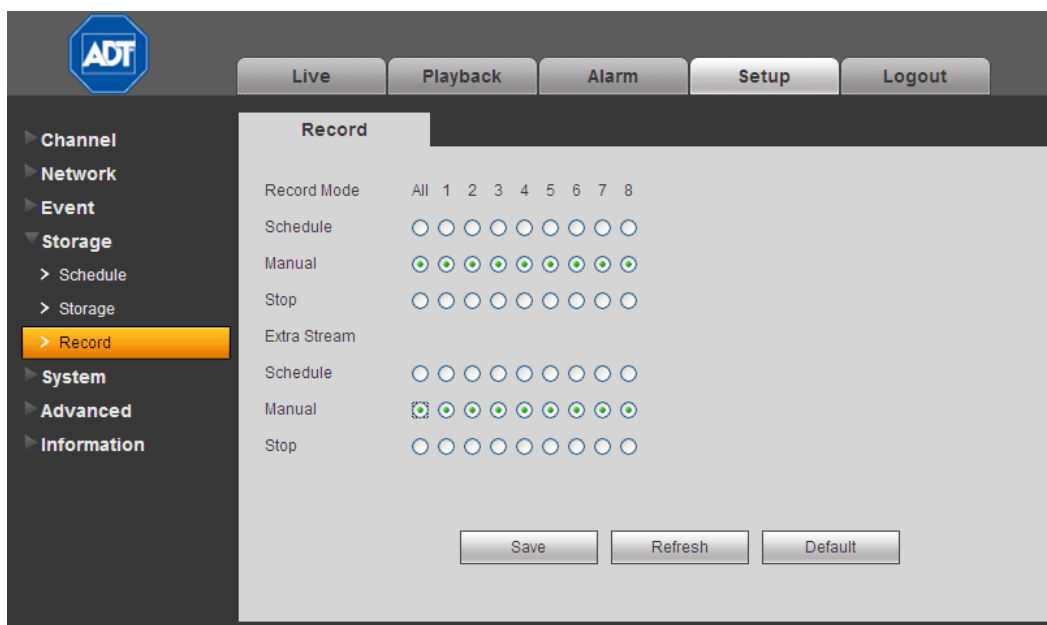

Figure 4-48

There are two modes of operation: Main Stream and Extra Stream; and three status settings for each mode: Schedule, Manual and Stop.

Schedule

Channel records as you have set in recording setup (*Main Menu > Setting > Schedule*)

Manual

Manual recording has highest priority, overriding the automatic recording setup.

Stop

Stop recording, overriding the automatic record setup.

To use the Record page:

1. Locate the channel you wish to control in the Record Mode row. The settings below the channel number correspond to that channel.
2. Click the radio button for the desired recording mode for each channel. Settings in the **All** column are applied to all channels.
3. Click **Save**.

4.6.5 System

4.6.5.1 General

The general screen includes **General**, **Date & Time** and **Holiday Setup** tabs.

General

Available options contained in the **General** tab are as follows. After making your selections, click the **Save** button.

The screenshot displays the ADT web interface. At the top, there are navigation tabs: Live, Playback, Alarm, Setup, and Logout. Below these, there are sub-tabs: General, Date&Time, and Holiday Setup. The General tab is active, showing the following configuration options:

- Device ID: DVR
- Device No.: 8
- Language: ENGLISH (dropdown menu)
- Video Standard: NTSC (dropdown menu)
- HDD Full: OverWrite (dropdown menu)
- Pack Duration: 60 Minute

At the bottom of the configuration area, there are three buttons: Save, Refresh, and Default.

Figure 4-49

Device ID

Enter a device name, such as DVR1, etc.

Device No

Enter the channel number.

Language

Select the desired language from the dropdown list.

Note: The device must reboot in order for a change in the language setting to be activated.

Video Standard

Select the desired video standard from the drop-down list, such as PAL, NTSC, etc.

HDD Full

Select from the drop-down the desired working mode when the hard disk is full:

- **Stop Recording.** If the current HDD becomes full and there is no secondary HDD or else it too has insufficient space, the system stops recording.

- **Overwrite.** If the current HDD becomes full and there is no secondary HDD or else it too has insufficient space, the system overwrites the previous files.

Pack Duration

Specify the recording duration. The value ranges from 1 to 120 minutes; the default value is 60 minutes.

Date and Time

Available options contained in the **Date & Time** tab are as follows. After making your selections, click the **Save** button.

Figure 4-50

Date Format

Use the drop-down list to select a date format

- YYY MM DD
- MM DD YYYY
- DD MM YYYY

Time Format

Select from the drop-down list from one of two options:

- 24-HOUR
- 12-HOUR.

System Time

This field displays the current system time. Click the **Sync PC** button to set your PC's current time as the system time.

DST

Check the box to enable Daylight Savings Time (DST).

DST Type

Set the DST beginning time and ending times, in either a date or week format.

Select the radio button that represents how you want the date displayed:

- Date.** Uses the format selected in the **Date Format** field.
- Day of Week.** Uses the format: Month Week Day Time, as follows.

Nov	▼	The 1st Week	▼	Sunday	▼	01 : 00
-----	---	--------------	---	--------	---	---------

 NTP

Check the box to enable the Network Time Protocol (NTP) function.

Time Zone

Use the drop-down list to select your time zone adjustment from GMT.

Server

Enter the address of the NTP server. Click the **Manual Update** button to force a time-sync with the NTP server.

Port

Set the NTP time server port.

Interval

Set the frequency in minutes at which the device syncs with the time server. You can force a sync using the **Manual Update** button. The range is 0-65535 minutes, with a default of 60.

Holiday Setup

Use this tab to set holiday dates.

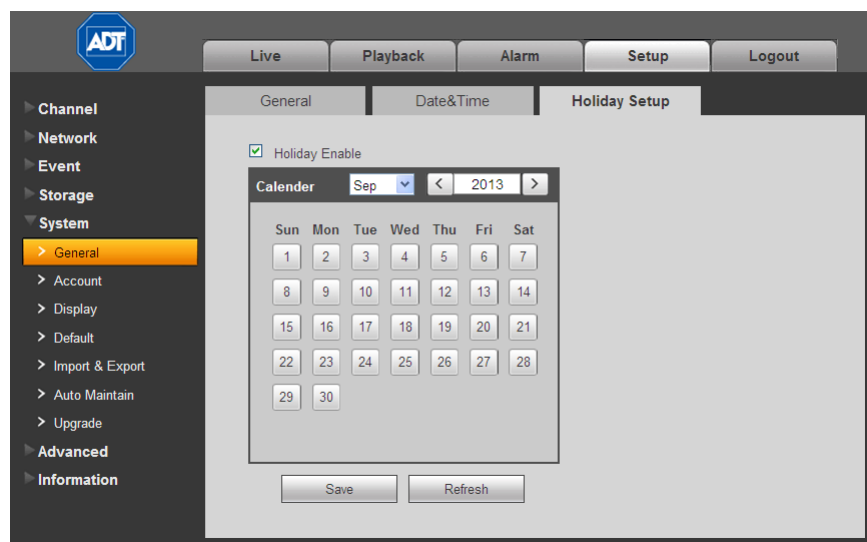

Figure 4-51

1. Check the **Holiday Enable** box.
2. In the calendar, select the date(s) and year you want to set as a holiday for the current channel.
3. Click **Save**.

4.6.5.2 Account

The Account page enables you to add new users or modify the accounts of existing ones. You can assign add or delete accounts, change rights or change passwords or assign users to groups.

Rules:

- User Names and Group Names can be no longer than 6 characters, including: alpha-numeric and the underline character.
- Passwords must be 1 – 6 numeric characters only.
- The factory default setup supports a maximum of 20 User accounts and 8 Group accounts, with two levels: user and admin. You can assign a user to a corresponding group and then set the rights for the respective users within the group.
- The User name and the Group name must be unique.
- One user can only be included in one group.

User

Click the User tab to add/remove users or to modify a user account. There are four default users: *admin*, *888888*, *666666* and a "hidden user" named *default*. User *666666* only has monitor rights; all others have administrators right.

The "hidden user" *default* is for system use only and cannot be deleted. When there is no login user, *default* automatically logs in. Monitor rights are set for this user so that you can view channels without logging in.

SN	User Name	Group Name	User MAC	Memo	Modify	Delete
1	888888	admin		admin(888) 's account		
2	666666	user		666666 user's account		
3	admin	admin		admin 's account		
4	default	user		default account		

Authority			
Control Panel	Shutdown	Real-time Monitor	Real-time MonitorChannel01
Real-time MonitorChannel02	Real-time MonitorChannel03	Real-time MonitorChannel04	Real-time MonitorChannel05
Real-time MonitorChannel06	Real-time MonitorChannel07	Real-time MonitorChannel08	Playback
PlaybackChannel01	PlaybackChannel02	PlaybackChannel03	PlaybackChannel04

Figure 4-52

To add a user:

1. Click the **Add User** button. The Add User dialog appears.
2. Enter the User Name, which can be a maximum of 6 characters, including alpha-numeric characters and the underline.
3. Enter and confirm the user Password, which must be 1 – 6 numeric characters only.
4. Use the drop-down list to select a Group for this user.
5. In the Authority field, check the boxes for the rights you want assigned for this user.
6. Enter the MAC and an optional Memo for the User.
7. Click **Save**.

Note:

- The user rights must not exceed the group rights.
- As a general rule, the general user should have lower rights than the administrator.

Figure 4-53**To delete a user:**



1. Click the **Delete** button . The Delete User dialog opens.
2. Click **Save** to confirm.

Figure 4-54

The *default* user cannot be deleted.

To modify a user:

1. Click the Modify button . The Modify User dialog opens.
2. Make changes to the user's account as necessary.
3. To modify the password:
4. Check the **Modify Password** box. Additional fields appear.
5. Enter the Old Password, Enter the New Password, and then Confirm the new Password.
6. Click **Save**.

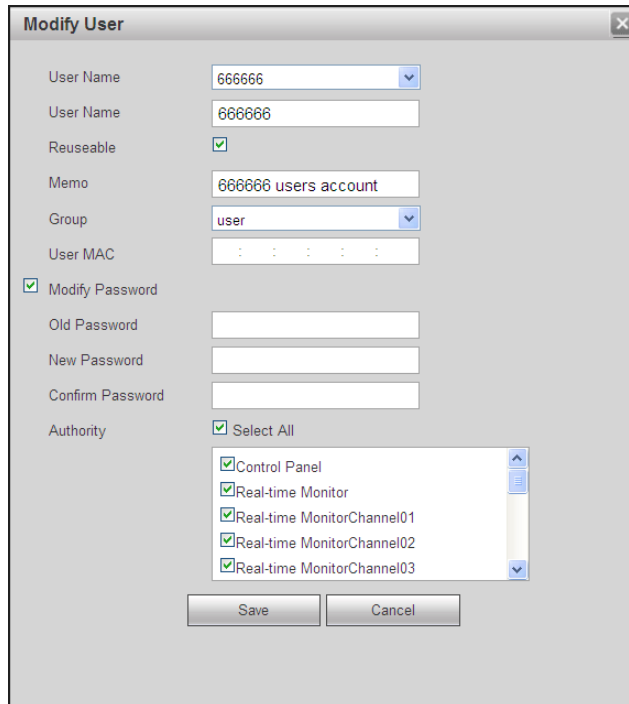

The screenshot shows the 'Modify User' dialog box with the following fields and options:

- User Name: 666666 (dropdown menu)
- User Name: 666666 (text input)
- Reuseable:
- Memo: 666666 users account (text input)
- Group: user (dropdown menu)
- User MAC: : : : : (text input)
- Modify Password:
- Old Password: (text input)
- New Password: (text input)
- Confirm Password: (text input)
- Authority: Select All
- Authority list (all checked):
 - Control Panel
 - Real-time Monitor
 - Real-time MonitorChannel01
 - Real-time MonitorChannel02
 - Real-time MonitorChannel03
- Buttons: Save, Cancel

Figure 4-55

Group

Click the Group tab to add/remove groups or to modify a group account.

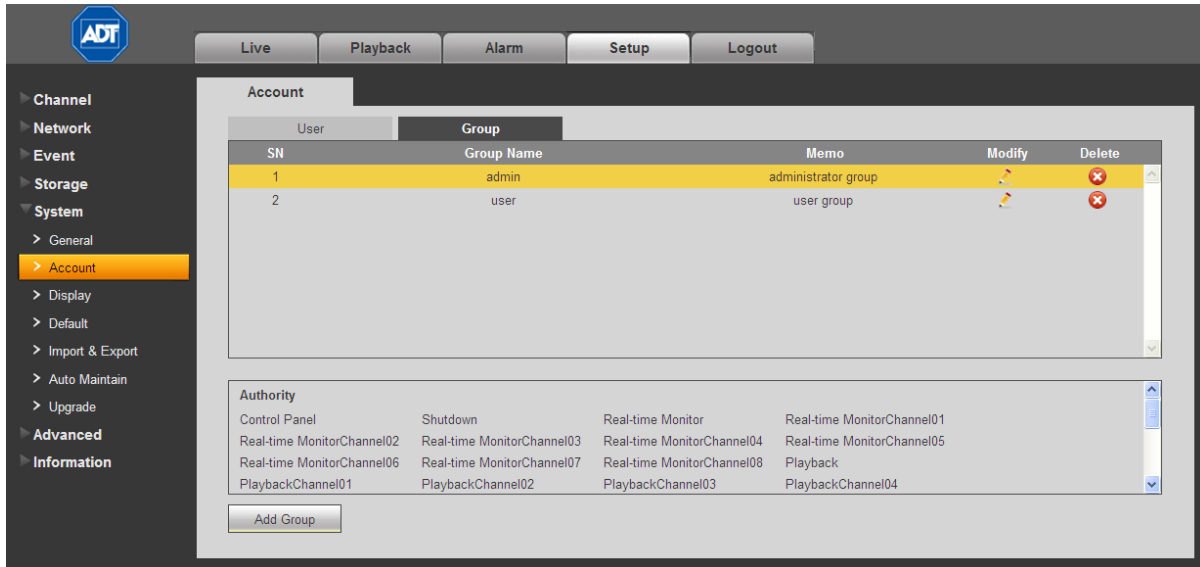

Figure 4-56

To add a group:

1. Click the **Add Group** button. The Add Group dialog opens.
2. Enter the Group Name, which can be a maximum of 6 characters, including alpha-numeric characters and the underline.
3. Add an optional memo.
4. Check the boxes to select the corresponding rights you want to assign to the group.
5. Click **Save**.

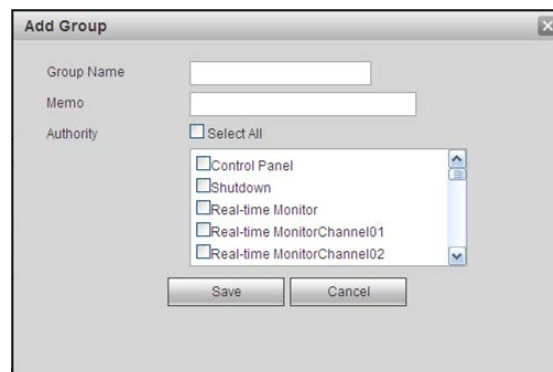

Figure 4-57

To delete a group:

1. Click the **Delete** button . The Delete Group dialog opens.
2. Click **Save** to confirm.

To modify a group:

1. Click the **Modify** button . The Modify Group dialog opens.
2. Make changes to the account as necessary.
3. Click **Save**.

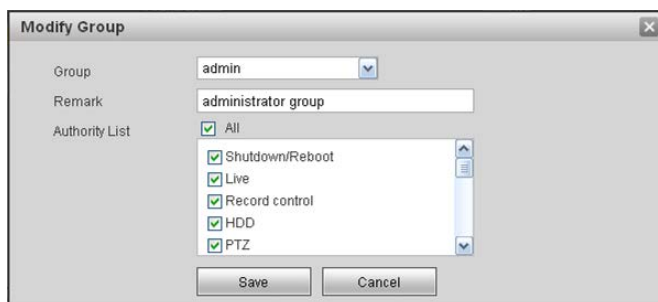

Figure 4-58

4.6.5.3 Display

The Display screen includes tabs for setting the GUI, TV Adjust, and Tour.

GUI

The GUI tab contains settings that affect the appearance of the graphical user interface. Click the Save button when you have completed setting your parameters.

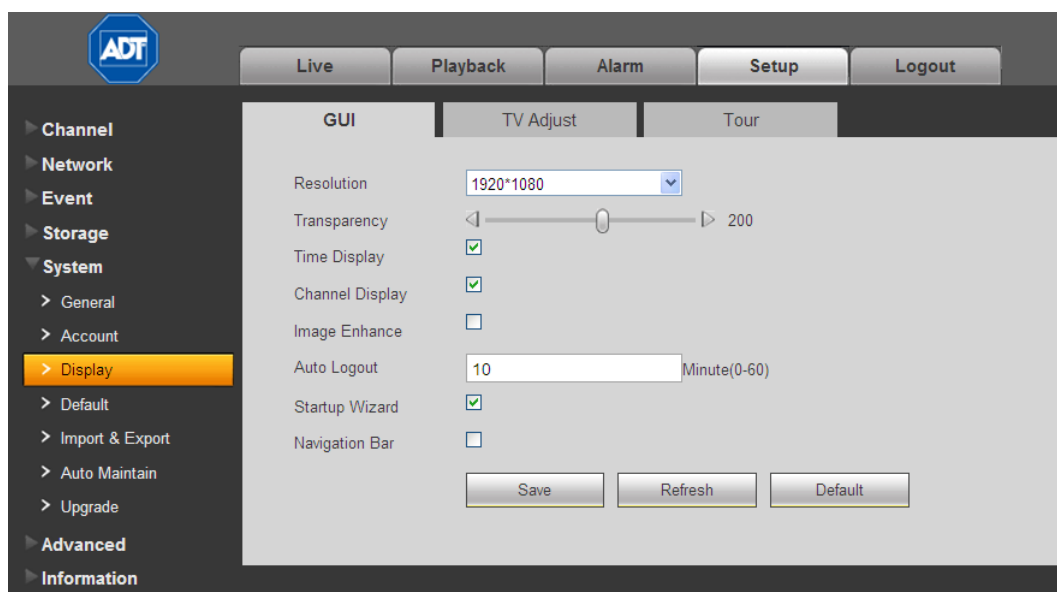

Figure 4-59

Resolution

Use the drop-down list to make your selection:

- 1280x1024 (default)
- 1280x720
- 1024x768
- 800x600

Note: The system must reboot to activate the current setup.

Transparency

Move the slider to adjust transparency. The value ranges from 128 to 255.

Time Display

Check the box to enable the system time to be displayed on the video monitor.

Channel Display

Check the box to enable the channel number to be displayed on the video monitor.

Image Enhance

Check the box to optimize the live video image quality.

Auto Logout

Enter a time in minutes after which the system will automatically logout.

Startup Wizard

Check the box to enable the wizard to appear at system startup.

Navigation Bar

Check the box to enable the navigation bar to be displayed on the video monitor.

TV Adjust

Use this to adjust margins and brightness settings on the video monitor.

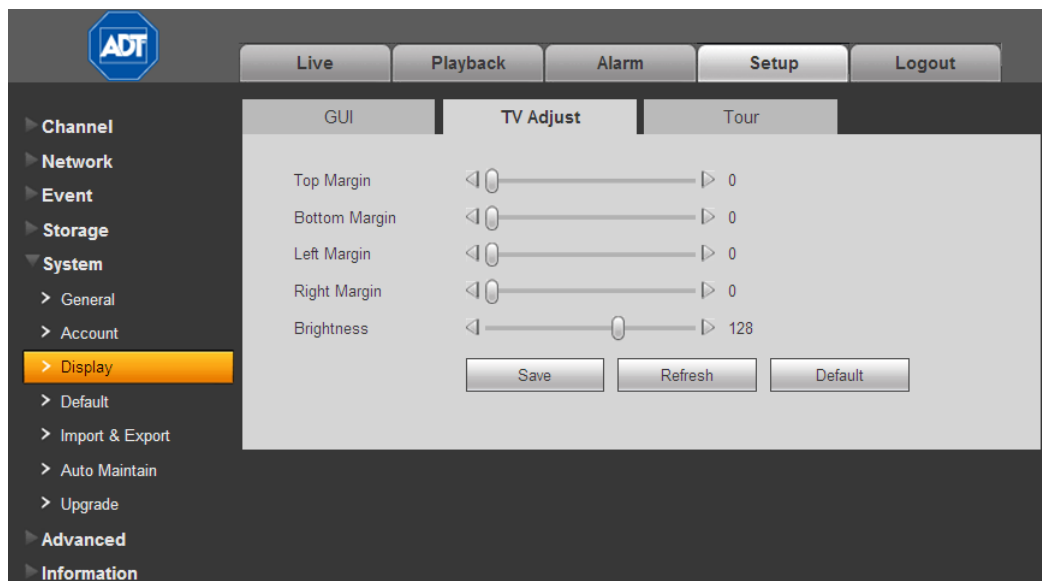

Figure 4-60

To set or edit TV Adjust:

1. Drag the slide bar to adjust each item to the desired setting.
2. After completing the setup, click the **Save** button.

Tour

The Tour feature presents an alternating display (much like a slideshow) of the channel(s) you have set to record. The Tour tab enables you to set the tour interval, split mode, tour type. Make your selections and then click **Save**.

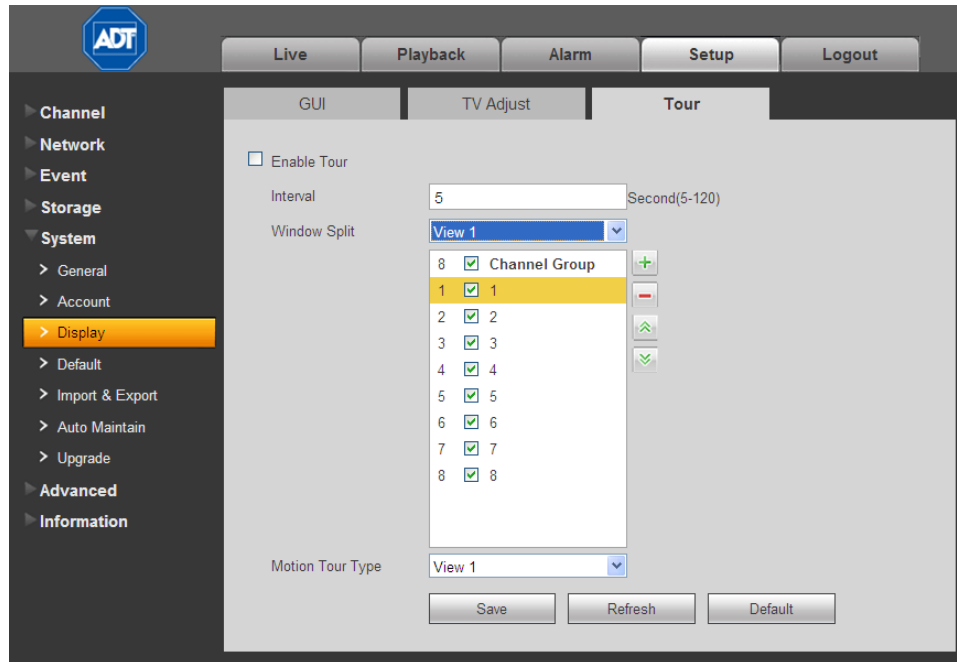

Figure 4-61

Enable Tour

Check the box to enable the tour feature.

Interval

Enter the time in seconds that a channel should be displayed before advancing to the next channel. The value ranges from 5 to 120s. The default setup is 5s.

Split

This section enables you to set how channels are displayed in the tour. The system can support 1/4/8/9/16/25 or 36 windows, depending on the number of channels connected to your device. In the following figure, a one-window display will be used. Channels 1 through 8 will be displayed in order. You can use the + and - buttons to add or delete channels; and use the up and down arrow buttons to move a channel to a different location in the sequence.

- View 1 displays 1 window
- View 4 displays 4 windows
- View 8 displays 8 windows, etc.

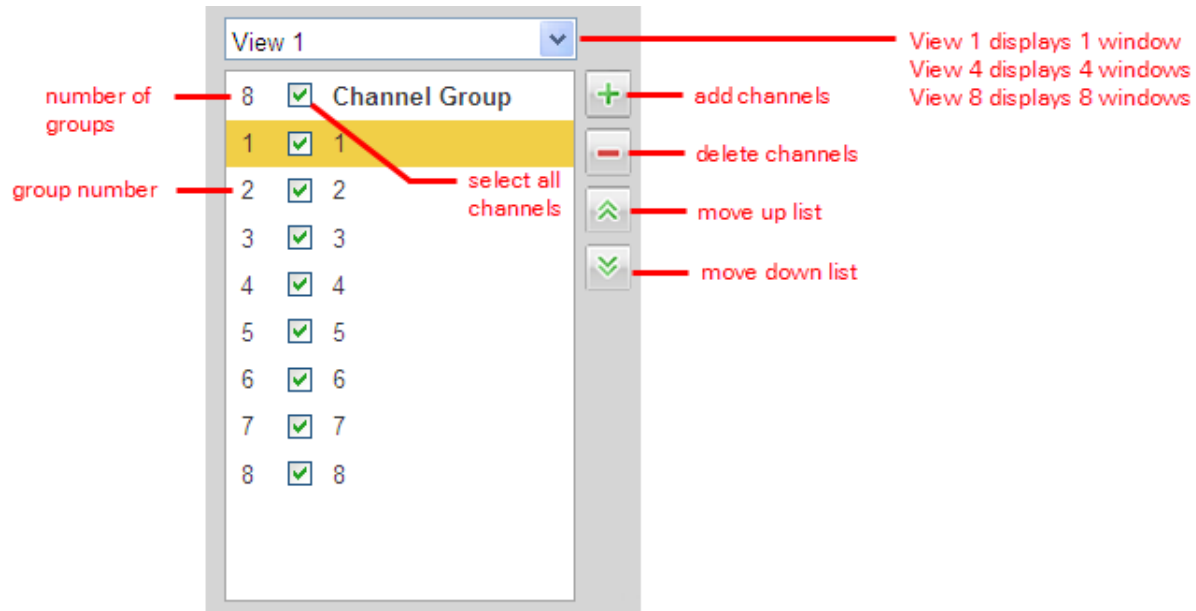

Example using Split

The following example details how to set up add channel groups to a 4- window split and then change the order in which the channels will be displayed.

1. Use the Window Split drop-down list to select View 4. This configuration contains two groups:
 - Group 1 will simultaneously display channels 1 through 4 for the set interval and then
 - Group 2 will simultaneously display channels 5 through 8

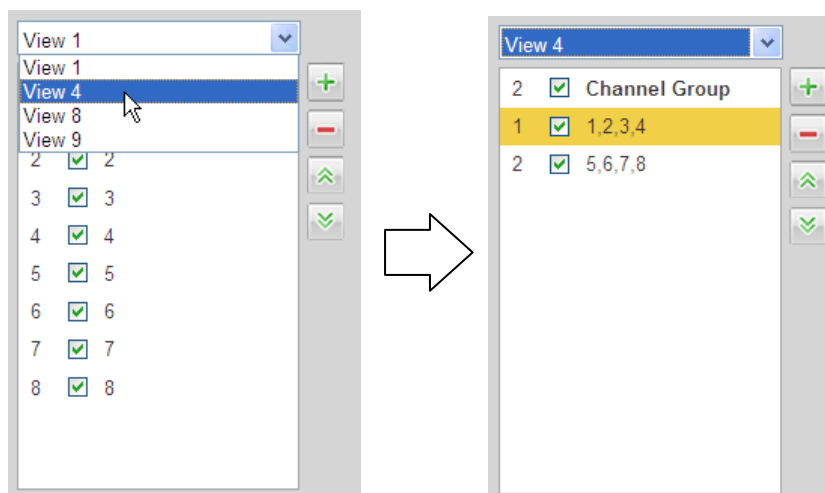

2. Click the + button to add a new channel group. The Add Channel Group dialog opens.
3. Click numbers 1, 3, 5, and 7 to select only odd channels for this new group.

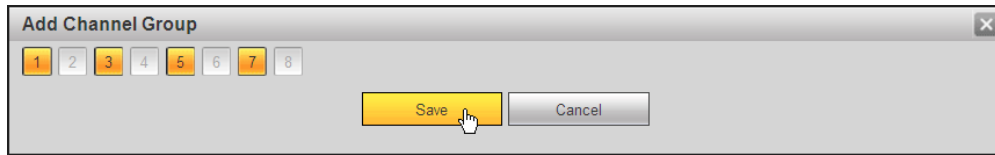

4. Click **Save**. Group number 3 is added, which includes only odd channels.

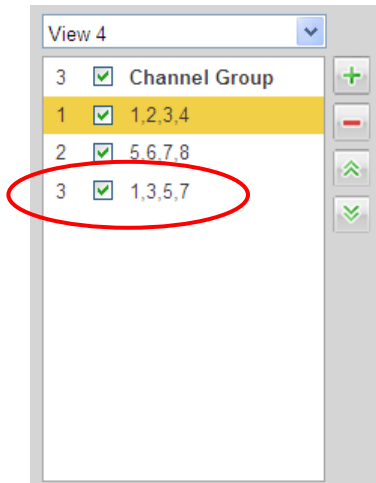

5. Click the + button again but this time click numbers 2, 4, 6, and 8 to select only even channels for the new group number 4, and click **Save**.
6. To relocate group 4 to be displayed before group 3 in the tour, select group 4 and then click the up arrow button. Group 4 is now number 3.

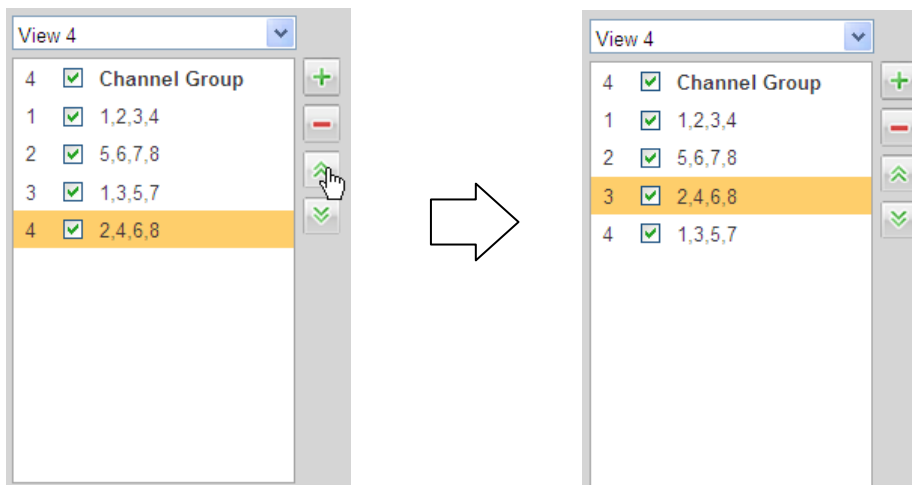

7. To remove groups 1 and 2 from the tour without deleting them, click the respective boxes to clear the checkmarks.

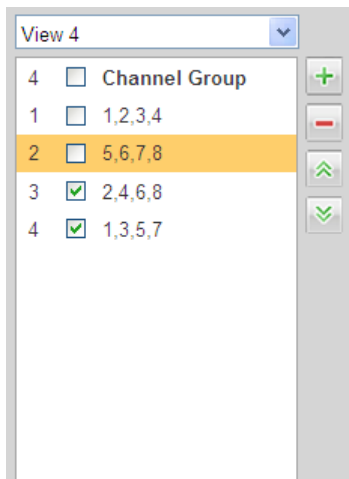

8. To completely remove groups 1 and 2, select them and then click the **-** button. What were labeled as groups 3 and 4 are now groups 1 and 2, respectively.

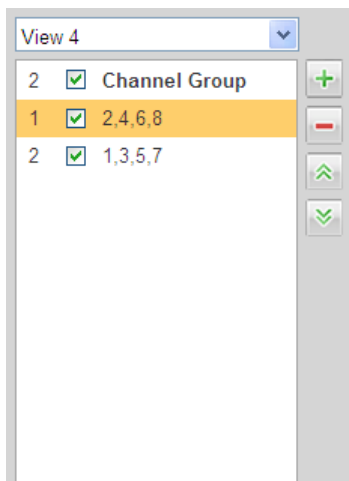

Motion Tour /Alarm Tour Type

Set the type of tour split to show for the Motion Detect Tour/Alarm Tour:

- View 1 displays the 1 window mode.
- View 8 displays the 8 window mode

4.6.5.4 Default

The Default page enables you to reset default settings to all sections of the web service from one location. Here you can select the Channel, Network, Event, Storage, or System sections individually; or else you can check the **All** box to select all items.

Check the boxes for the sections you wish to reset and then click the **Set Default** button.

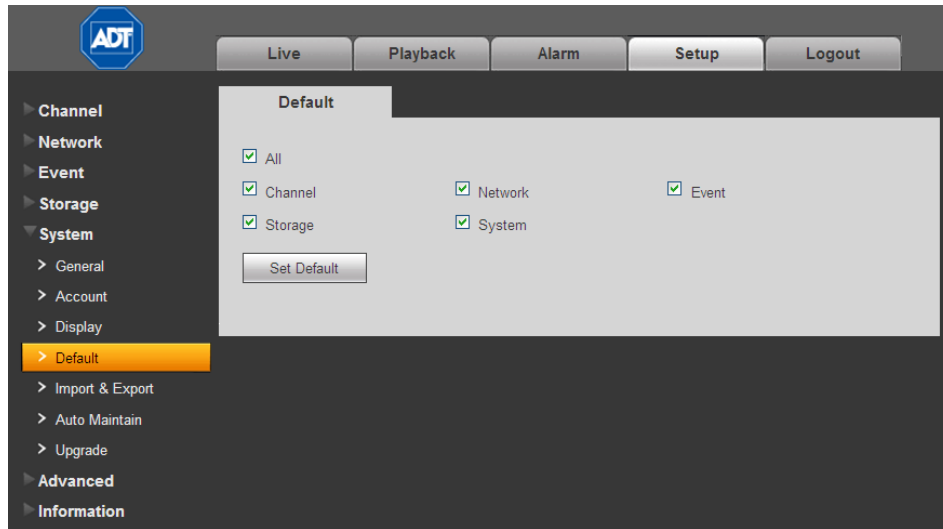

Figure 4-62

4.6.5.5 Import/Export

The Import / Export page provides a method for using parameters set for either the Web Service or local PC-based system and transferring them to the other location.

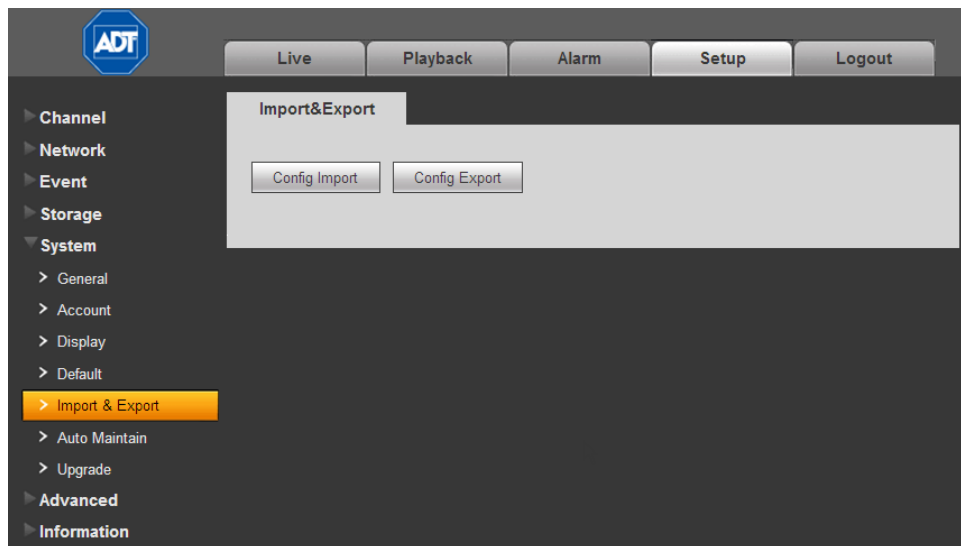

Figure 4-63

Import. This feature displays an Open dialog that you can use to navigate to and select local PC setup files to import to the Web Service.

Export. This feature opens a Save As dialog that you can use to export the corresponding Web Service settings to your local PC.

To perform one of these functions, click the corresponding button and then use the resulting dialog to navigate to the desired location.

4.6.5.6 Auto Maintenance

The Auto Maintain page enables you to setup automatic system reboots and deletion of old files at pre-set intervals.

To setup Auto Reboot:

1. Use the drop-down menu to select the day of the week for the reboot.
2. Input the time of day for the reboot.
3. Click **Save**.
4. For instant results, click **Manual Reboot**.

To setup Auto Delete:

1. Use the drop-down menu to select the frequency of the auto delete.
2. Click **Save**.
3. If you want to use the auto delete old files function, you must set the file period.

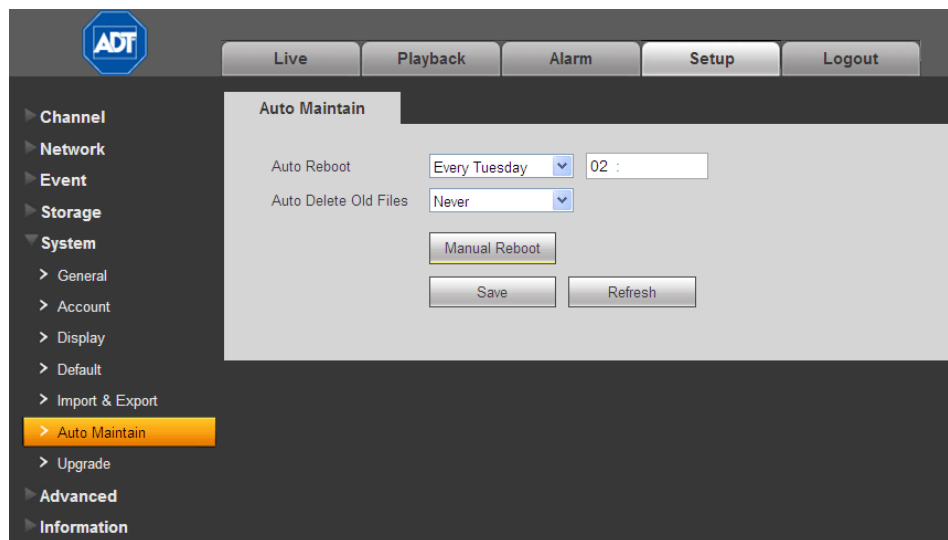

Figure 4-64

4.6.5.7 Upgrade

The Upgrade page enables you to install the latest firmware files.

To upgrade your DVR:

1. Click the **Browse** button.
2. In the ensuing dialog, navigate to and select the upgrade file. The filename will have a **.bin** extension.

3. Click the **Update** button. During the upgrade process, do not unplug the power cable or network cable, or shutdown the device.

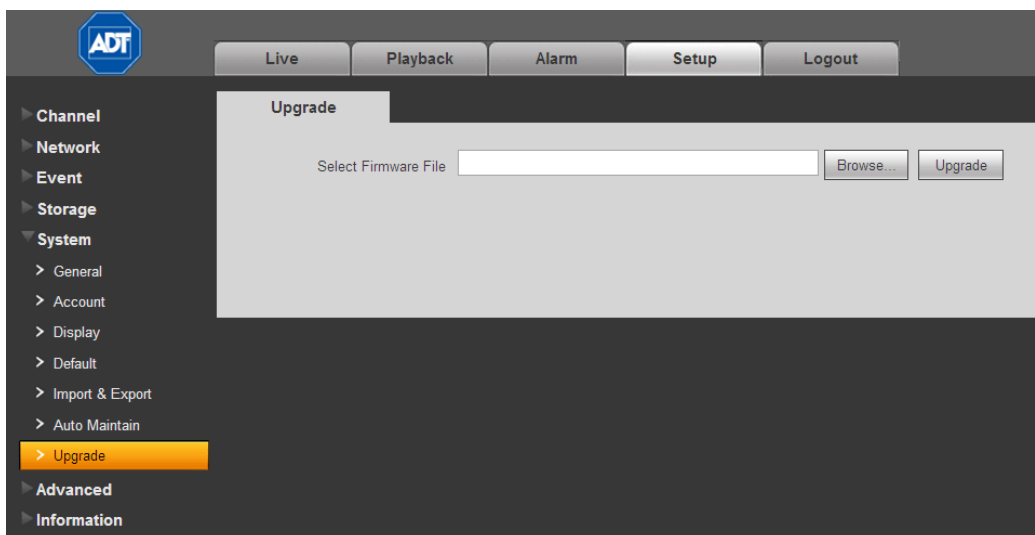

Figure 4-65

4.6.6 Advanced

4.6.6.1 Text Overlay

The text overlay function is for financial applications. This feature overlays the user's credit card information over the video image. It includes Sniffer, Information Analysis and Title Overlay function. The Sniffer mode includes COM and Network options, which presents different items on the page. Click **Save** after making your selections.

COM Type

Text Overlay in COM mode is shown below in Figure 4-66.

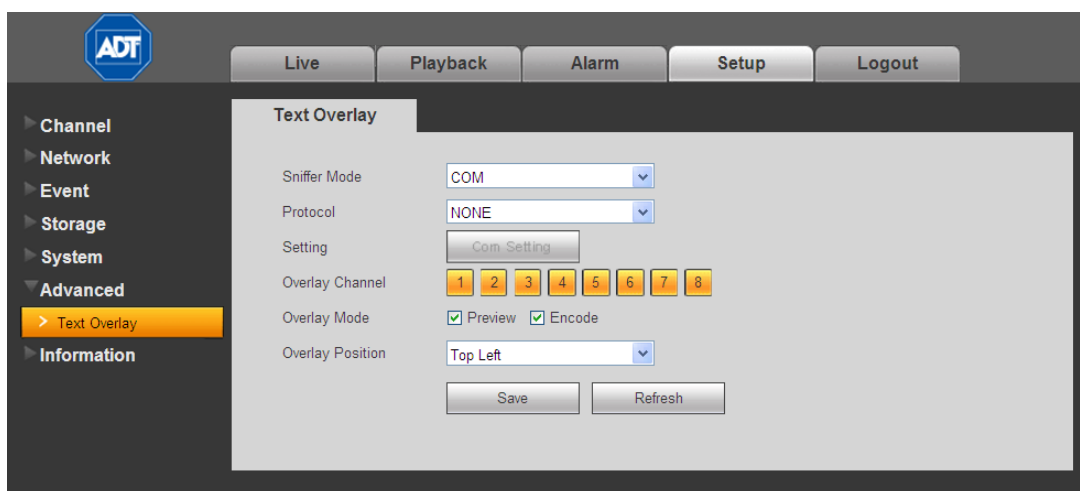

Figure 4-66

The following describes the various entries in the COM mode screen:

Sniffer Mode

Select COM from the drop-down menu.

Protocol

Make a selection from the dropdown list: POS or NONE.

Setting

This function is grayed out for this operation.

Overlay Channel

Click the numbers representing the channels on which you want to overlay the card number.

Overlay Mode

Check the box for the option(s) you want to enable: Preview and Encode. Preview means the card number is overlaid in the live video. Encode means the card number is overlaid in the recorded file.

Overlay Position

From the dropdown list, select the position where you want the overlay to appear: Top Left, Top Right, Bottom Left, and Bottom Right.

NET (Network) Type

The Text Overlay screen in network mode can be set up in two different types: with or without the ATM protocol.

With the protocol

For network mode with the ATM protocol, you must set the source IP and destination IP. Sometimes, you will also need to input corresponding port number.

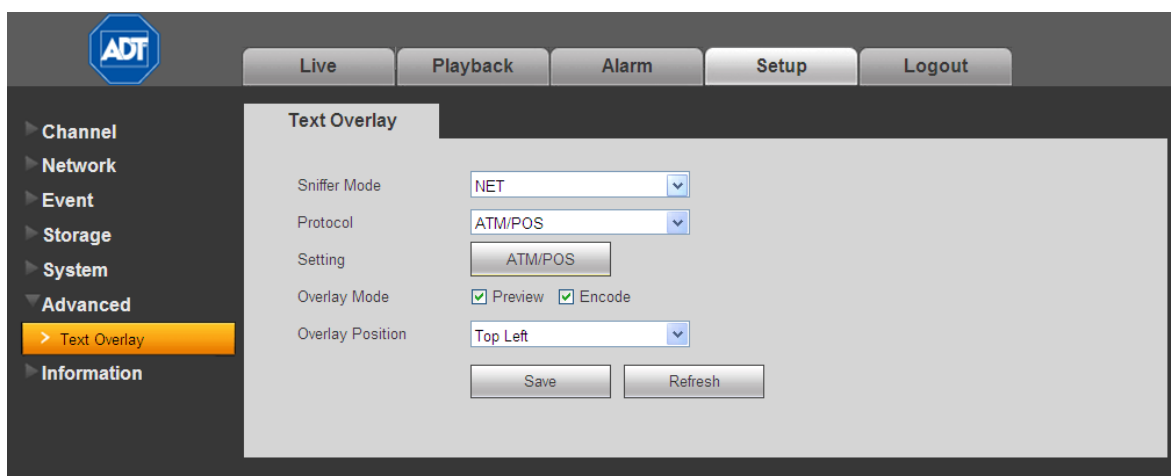

Figure 4-67

Sniffer Mode

Select NET from the drop-down menu.

Protocol

Select ATM/POS.

Setting

Click the ATM/POS button to open the Setup dialog, as follows.

Key Words	Start Position	Length	Value
Key Words1	1	0	
Key Words2	1	0	
Key Words3	1	0	
Key Words4	1	0	
Key Words5	1	0	
Key Words6	1	0	

Figure 4-68

Overlay Mode

Check the box for the option(s) you want to enable: Preview and Encode. Preview means the card number is overlaid in the live video. Encode means the card number is overlaid in the recorded file.

Overlay Position

From the dropdown list, select the position where you want the overlay to appear: Top Left, Top Right, Bottom Left, and Bottom Right.

Without the ATM protocol

The Text Overlay screen in network mode without the protocol is shown in Figure 4-69.

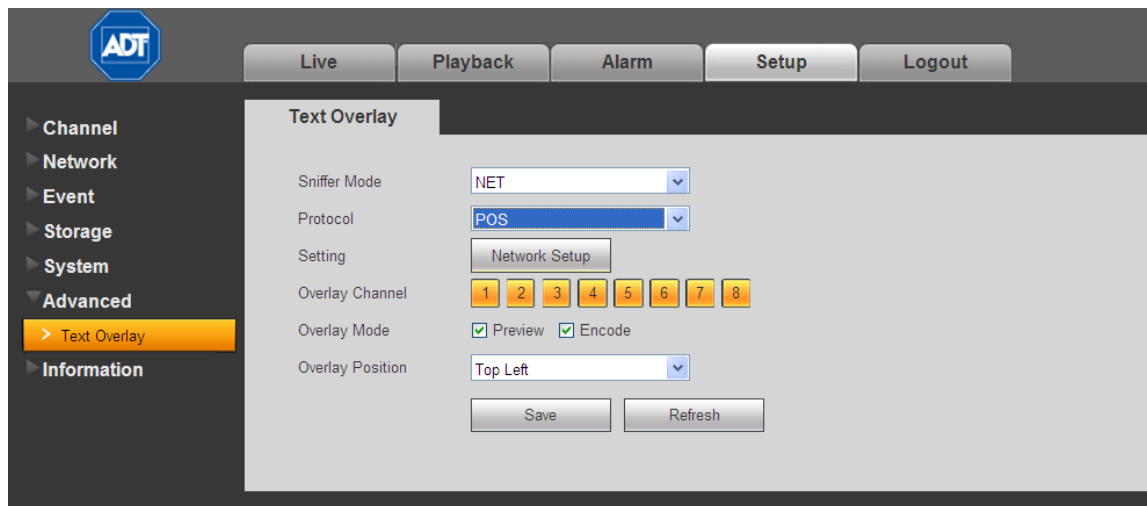

Figure 4-69

The following describes the various entries in the POS protocol screen:

Sniffer Mode

Select NET from the drop-down menu.

Protocol

Select POS from the drop-down menu.

Setting

Click the Network Setup button to bring up the IP Setup dialog.

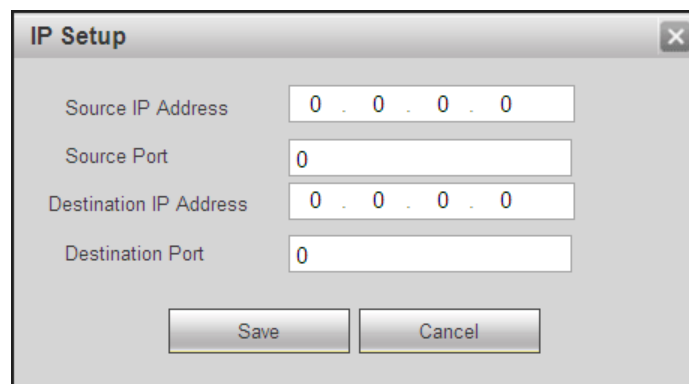

Figure 4-70

Source IP refers to host IP address that sends out information (usually it is the device host.)

Destination IP refers to other systems that receive information. Usually you do not need to set the source port and target port.

There are a four IP groups. The Record Channel applies only to one group (optional). Having six Frame ID groups can help ensure validity of the information.

Overlay Channel

Click the numbers representing the channels on which you want to overlay the card number.

Overlay Mode

Check the box for the option(s) you want to enable: Preview and Encode. Preview means the card number is overlaid in the live video. Encode means the card number is overlaid in the recorded file.

Overlay Position

From the dropdown list, select the position where you want the overlay to appear: Top Left, Top Right, Bottom Left, and Bottom Right.

4.6.7 Information

4.6.7.1 Version

The version screen displays system hardware features, software version, release date, etc. The listed information is for reference only.



Figure 4-71

4.6.7.2 Log

This screen displays the system log. See Figure 4-72. Refer to the following for parameter information.

Type

Log types include: System Operation, Configuration Operation, Data Operation, Event Operation, Record Operation, User Management and Log Clear.

Start Time

Set the start time of the requested log.

End time

Set the end time of the requested log.

Search

Select the log type from the drop down list and then click search button to view the list.

Click the stop button to terminate current search operation.

Detailed Information

You can select one item to view detailed information.

Clear

You can click this button to delete all displayed log files. Note that the system does not support clear by type.

Backup

Click this button to backup log files to the local PC.

The screenshot shows the ADT web interface. The top navigation bar contains buttons for Live, Playback, Alarm, Setup, and Logout. The left sidebar has a navigation menu with categories: Channel, Network, Event, Storage, System, Advanced, and Information. Under Information, there are sub-items: Version, Log (highlighted), and Online User. The main content area is titled 'Log' and shows search filters for Start Time (2013-01-05 00:00:00) and End Time (2013-01-07 00:00:00). A search button is present, and it indicates 'Matched 127 logs'. Below this is a table with the following data:

No.	Time	Event
1	2013-01-05 00:29:13	User logged in
2	2013-01-05 00:29:20	System Upgrade
3	2013-01-05 00:33:43	System Upgrade
4	2013-01-05 00:33:43	Shut down
5	2013-01-05 00:33:43	Boot up
6	2013-01-05 00:33:43	Video Loss
7	2013-01-05 00:33:43	Video Loss
8	2013-01-05 00:33:43	Video Loss

Below the table is a 'System Log Info' section. At the bottom right of the main content area, there are navigation controls including a 'Go To' field with the value '1' and a 'Clear' button. A 'Backup' button is located at the bottom left of the main content area.

Figure 4-72

4.6.7.3 Online User

The Online User page is shown below in Figure 4-73.

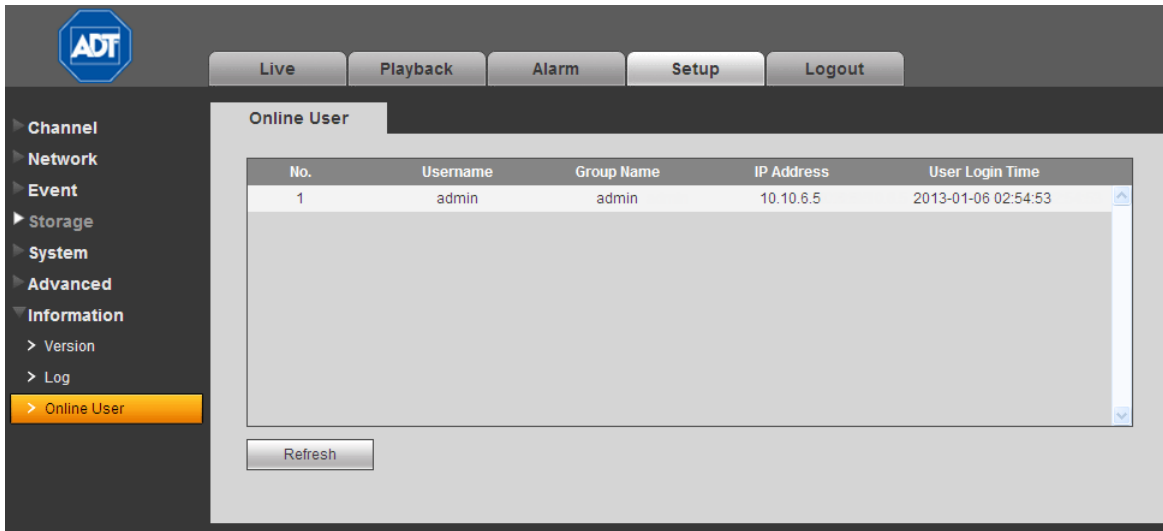

Figure 4-73

4.7 Logout

Click the **Logout** button to log out of the Web Service. The system reverts to the **Login** dialog. You must input your username and password to log in again.

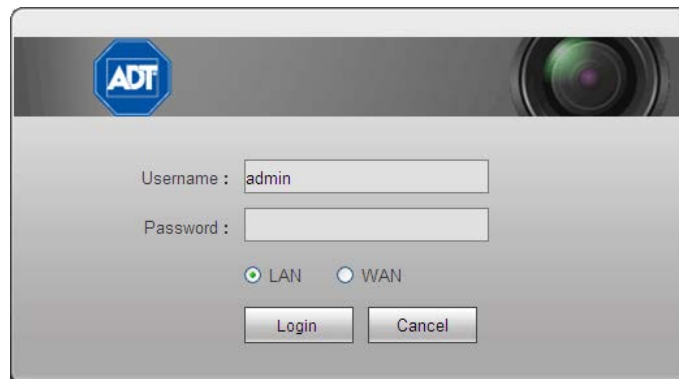

Figure 4-74

4.8 Un-install Web Control

You can use web un-install tool “uninstall web.bat” to un-install web control.

Note: Be sure to close all web pages before you un-install.

Appendix A Troubleshooting and Daily Maintenance

Troubleshooting

1. DVR does not boot up properly

Possible reasons:

- Input power is not correct
- Power connection is not correct
- Power switch button is damaged
- Program upgrade is wrong
- HDD malfunction or something wrong with the HDD ribbon
- Seagate DB35.1, DB35.2, SV35 or Maxtor 17-g has a compatibility problem — Upgrade to the latest version to solve this problem.
- Main board is damaged

2. DVR often automatically shuts down or stops running

Possible reasons:

- Input voltage is not stable or it is too low.
- HDD malfunction or something wrong with the ribbon
- Video signal is not stable
- Working environment is too harsh; too much dust
- Hardware malfunction

3. System cannot detect hard disk

Possible reasons:

- HDD is damaged
- HDD ribbon is damaged
- HDD cable connection is loose
- Main board SATA port is damaged

4. There is no video output on the one-channel, multiple-channel or all-channel output

Possible reasons:

- Program is not compatible—upgrade to the latest version.
- Brightness is set to 0. Restore factory default setup.
- There is no video input signal or it is too weak
- Check the Privacy Mask setup or your screen saver
- DVR hardware malfunction

5. Real-time video color is distorted

Possible reasons:

- When using BNC output, the NTSC and PAL setup is not correct. The real-time video displays in monochrome
- DVR and monitor resistance is not compatible
- Video transmission is too long or is excessively degraded
- DVR color or brightness setup is not correct

6. Cannot search local recordings

Possible reasons:

- HDD ribbon is damaged
- HDD is damaged
- Upgraded program is not compatible
- The recorded file has been overwritten
- The Record function has been disabled

7. Video is distorted when searching local recordings

Possible reasons:

- Video quality setup is too low
- Program read error, bit data is too small. If there is a mosaic pattern in the full screen—
Restart the DVR to solve this problem
- HDD data ribbon error
- HDD malfunction
- DVR hardware malfunction

8. There is no audio when monitoring or during playback

ADT does not support Audio functions at this time.

9. Time display is not correct

Possible reasons:

- Setup is not correct
- Battery contact is not correct or voltage is too low
- Crystal is damaged

10. DVR cannot control Pan/Tilt/Zoom (PTZ).

The DVR5 1xxC Series does not support the Pan/Tilt/Zoom (PTZ) function.

11. Motion detection function does not work

Possible reasons:

- Period setup is not correct
- Motion detection zone setup is not correct
- Sensitivity is too low
- For some versions, there is a hardware limitation

12. Cannot log in client end or web.

Possible reasons:

- The DVR is not compatible with Windows Vista
- The ActiveX control has been disabled
- Display card driver needs to be upgraded to dx8.1 or higher
- Network connection error
- Network setup error
- Password or User Name is invalid
- Client end is not compatible with the DVR program

13. There is a mosaic pattern on the screen—no video when viewing live video or playback file

Possible reasons:

- Poor network quality
- Client end resources are limited
- There is a multicast group setup on the DVR. This mode can result in a mosaic screen. Usually this mode is not recommended
- There is a Privacy Mask or channel protection setup
- Current user has no right to monitor
- DVR local video output quality is of poor quality

14. Network connection is not stable

Possible reasons:

- Network is not stable
- IP address conflict
- MAC address conflict
- PC or DVR network card is damaged

15. Burner error /USB back error

Possible reasons:

- Burner and DVR are on the same data cable
- System uses too many CPU resources.—Stop recording first, and then begin the backup
- Data amount exceeds the backup device capacity. It may result in burner error
- Backup device is not compatible
- Backup device is damaged

16. Recording storage insufficient

Possible reasons:

- Camera quality is too low
- Lens is dirty
- Camera is installed facing a light source
- Camera aperture setup is not correct
- HDD capacity is insufficient
- HDD is damaged

17. Cannot playback the downloaded file

Possible reasons:

- There is no media player
- Requires graphic acceleration software upgrade to DXB8.1 or higher
- There is no DivX503Bundle.exe control when you play the file transformed to AVI via the media player
- There is no DivX503Bundle.exe or ffdshow-2004 1012 .exe in Windows XP OS

18. Forgot local menu operation password or network password

Contact your local service engineer for help solving this problem.

Daily Maintenance

- Check and maintain the device regularly.
- Regularly use a brush to clean the board, socket connector and chassis.
- Properly ground the device to protect against video disturbances.
- Keep the device away from static or induced voltage.
- Unplug the power cable before you remove the video signal cable or RS485 cable.
- To avoid HDD malfunction, always shut down the device properly, using the Shutdown function in the menu.
- Locate the device away from the direct sunlight or other heating sources.
- Ensure that the device is properly ventilated.

Appendix B Specifications

Feature	Parameter	Description
System	Main Processor	High-performance industrial embedded micro controller
	OS	Embedded LINUX
	System Resources	Multiplex operations: simultaneous multiple-channel record, multiple-channel playback and network operation
	Interface	User-friendly graphical user interface
	Input Devices	USB mouse
	Input Method	Alphanumeric characters
	Shortcut Function	Copy/paste operation, USB mouse right-click shortcut menu, double click USB mouse to switch screens
Compression Standard	Video Compression	H.264
Video Monitor	Video Input	4 Channel 4-CH composite video input: (NTSC/PAL) BNC (1.0V _{P-P} , 75Ω)
		8 Channel 8-CH composite video input: (NTSC/PAL) BNC (1.0V _{P-P} , 75Ω)
		16 Channel 16-CH composite video input: (NTSC/PAL) BNC (1.0V _{P-P} , 75Ω)
	Video Output	<ul style="list-style-type: none"> 1-ch PAL/NTSC, BNC (1.0V_{P-P}, 75Ω) composite video signal output 1-ch HDMI output 1-ch VGA output Supports TV/VGA/HDMI video output at the same time
	Video Standard	PAL (625 line, 50f/s), NTSC (525 line, 60f/s)
	Record Speed	Real-time Mode: PAL 1f/s to 25f/s per channel and NTSC 1f/s to 30f/s per channel
	Video Partition	4 Channel 1/4 windows (option)
		8 Channel 1/4/8 windows
		16 Channel 1/4/8/9/16 windows
	Monitor Touring	Supports monitor tour functions such as motion detection, and scheduled auto control
	Resolution (PAL/NTSC)	PAL (625TV Line, 50f/s), NTSC (525TV line, 60f/s)
		Real-time monitor: D1 704x576/704x480 Playback: D1/4CIF (704x576/704x480); 2CIF (704x288/704x240); CIF (352x288/352x240); QCIF (176x144/176x120) Supports dual streams. Extra stream resolution: CIF (352x288/ 352x240); QCIF (176x144/176x120)
	Image Quality	6-level image quality (adjustable)
Privacy Mask	The system supports one privacy mask of user-defined size in full screen, with a maximum of 4 zones.	
Image Information	Channel information, time information and privacy mask zone	
TV Adjust	Adjust TV output zone suitable to anamorphic video	
Channel Lock	Cover secret channel with black screen (though system is encoding normally) to prevent unauthorized users from viewing	
Channel Information	Channel name, screen lock status, video loss status and motion detection status are shown on the bottom left of display screen.	
Color Configuration	Hue, brightness, contrast, saturation and gain setup for each channel.	

Feature	Parameter	Description		
Hard Disk	Hard Disk	1 built-in SATA port supports 1 HDD up to 4TB		
	Hard Disk Occupation	Video: 56-900MByte/h		
Record and Playback	Record Mode	Manual recording, Motion detection recording, Scheduled recording Priority: Manual > Motion Detection > Schedule		
	Record Length	1 to 120 minutes single record duration (default setup is 60 minutes)		
	Playback Repeat	When hard disk is full, system can overwrite previous video file		
	Record Search	Various search engines such as time, type and channel		
	Playback Mode	Various fast play, slow play speeds, manual frame by frame playback and reverse play mode		
	File Switch	<ul style="list-style-type: none"> • Can switch to previous or next file or any file in current play list • Can switch to file on other channel of the same time • Supports file continuous play: when the current file ends, plays the next file on the current channel 		
	Multi-channel Playback	4 Channel	8 Channel	16 Channel
		1-channel, 4-channel	1-channel, 4-channel, 8-channel	1-channel, 4-channel, 8-channel, 9-channel and 16-channel
Window Zoom	Switch between self-adaptive screen/full screen during playback			
Partial Enlargement	When in one-window full-screen playback mode, select any zone to activate partial enlargement			
Backup Function	Backup Mode	HDD backup		
		Supports peripheral USB backup device (flash drive, portable disk, etc.)		
		Supports network download and backup		
Network Function	Network control	View monitor channel remotely		
		DVR configuration through client end and web browser		
		Upgrade via client end or browser to initiate remote maintenance		
		View alarm information such as external motion detection and video loss via client		
		Multiple devices share information via corresponding software such as professional surveillance software (ADT VideoView)		
		File download backup and playback		
Motion Detection and Alarm	Motion Detection	<ul style="list-style-type: none"> • Zone setup: supports 396 (PAL 22x18, NTSC 22x15) detect zones • Various sensitivity levels • Alarm can activate record or screen message prompt 		
	Video Loss	Alarm can activate screen message prompt		
	External Alarm	N/A		
	Manual Alarm	N/A		
	Alarm Input	N/A		
	Alarm Output	N/A		
	Alarm Relay	N/A		
Interface	USB Interface	2 USB 2.0 ports		
	Network	RJ45 10M/100M self-adaptable Ethernet port		
	RS232	N/A		
	RS485	N/A		

Feature	Parameter	Description						
System Information	Hard Disk Information	Displays HDD current status						
	Data Stream Statistics	Data stream statistics for each channel (in wave mode)						
	Log statistics	<ul style="list-style-type: none"> Backup to 1024 log files Supports various search engines such as time and type 						
	Version	Displays version information: channel amount, system version and release date						
	On-line user	Displays current on-line user						
User Management	User Management	<ul style="list-style-type: none"> Multi-lever user management; various management modes Integrated management for local user and network user Configurable user power Supports user /group and its corresponding rights modification No limit to the user or group amount 						
	Password Authentication	<ul style="list-style-type: none"> Password modification Administrator can modify other user's password Account lock strategy Five login failures in thirty minutes can result in account lock 						
Upgrade		USB, client end or upgrade tool						
Login, Logout and Shutdown		<p>Password login protection to ensure safety</p> <p>User-friendly interface upon login.</p> <p>Provides the following options: Logout /Shutdown/ Restart</p> <p>Authentication rights for shutdown to ensure only authorized people can turn off DVR</p>						
General Parameters	Power	+12VDC						
	Power Consumption	≤10W (with power adapter, excluding HDD)						
	Working Temperature	14°F to 131°F (-10°C to +55°C)						
	Working Humidity	10 to 90%						
	Air Pressure	86kpa - 106kpa						
	Dimensions (W x D x H)	<table border="1"> <thead> <tr> <th>4 Channel</th> <th>8 Channel</th> <th>16 Channel</th> </tr> </thead> <tbody> <tr> <td>8.07" x 8.07" x 1.57" (205x 205 x40mm)</td> <td>8.07" x 8.07" x 1.57" (205 x 205 x40mm)</td> <td>10.63" x 8.07" x 1.57" (270 x 205 x 40mm)</td> </tr> </tbody> </table>	4 Channel	8 Channel	16 Channel	8.07" x 8.07" x 1.57" (205x 205 x40mm)	8.07" x 8.07" x 1.57" (205 x 205 x40mm)	10.63" x 8.07" x 1.57" (270 x 205 x 40mm)
	4 Channel	8 Channel	16 Channel					
	8.07" x 8.07" x 1.57" (205x 205 x40mm)	8.07" x 8.07" x 1.57" (205 x 205 x40mm)	10.63" x 8.07" x 1.57" (270 x 205 x 40mm)					
Weight	<table border="1"> <thead> <tr> <th>4 Channel</th> <th>8 Channel</th> <th>16 Channel</th> </tr> </thead> <tbody> <tr> <td>1.1lb (0.50kg), excluding HDD</td> <td>1.1lb (0.50kg), excluding HDD</td> <td>1.65lb (0.75kg), excluding HDD</td> </tr> </tbody> </table>	4 Channel	8 Channel	16 Channel	1.1lb (0.50kg), excluding HDD	1.1lb (0.50kg), excluding HDD	1.65lb (0.75kg), excluding HDD	
4 Channel	8 Channel	16 Channel						
1.1lb (0.50kg), excluding HDD	1.1lb (0.50kg), excluding HDD	1.65lb (0.75kg), excluding HDD						
Installation Mode	Desktop installation							

Appendix C Compatible Backup Device List

Note: Upgrade the DVR firmware to the latest version to ensure the accuracy of the table below. If you use a USB drive, confirm that the format is FAT or FAT32.

Compatible USB Drive List

Manufacturer	Model	Capacity
Aigo	L8315	16GB
Kingax	Super Stick	128M
Kingax	Super Stick	256M
Kingax	Super Stick	512M
Kingax	Super Stick	1G
Kingax	Super Stick	2G
Kingston	DataTraveler II	1G
Kingston	DataTraveler II	2G
Kingston	DataTraveler	1G
Kingston	DataTraveler	2G
Kingston	Data Traveler	1G
Kingston	Data Traveler	16GB
Kingston	Data Traveler	32GB
Kingston	Data Traveler Locker+	32GB
Lexar	Lexar	256MB
Maxell	USB Flash Stick	128M
Maxell	USB Flash Stick	256M
Maxell	USB Flash Stick	512M
Maxell	USB Flash Stick	1G
Maxell	USB Flash Stick	2G
Netac	U210	128M
Netac	U210	256M
Netac	U210	512M
Netac	U210	1G
Netac	U210	2G
Netac	U208	4G
Netac	U228	8GB
SanDisk	Cruzer Micro	512M
SanDisk	Cruzer Micro	1G
SanDisk	Cruzer Micro	2G
SanDisk	Cruzer Freedom	256M
SanDisk	Cruzer Freedom	512M
SanDisk	Cruzer Freedom	1G
SanDisk	Cruzer Freedom	2G
SanDisk	Cruzer micro	2G
SanDisk	Cruzer micro	8G
SanDisk	Ti Cool	2G
SanDisk	Hongjiao	4G
SanDisk	250	16GB
Teclast	Ti Cool	128M

Manufacturer	Model	Capacity
Teclast	Ti Cool	256M
Teclast	Ti Cool	512M
Teclast	Ti Cool	1G

Compatible USB DVD Burner List

Note: Upgrade the DVR firmware to the latest version to ensure the accuracy of the table below.

Manufacturer	Model
Sony	DRX-S70U
Benq	TW200D

Compatible SATA HDD List

NOTE: Upgrade the DVR firmware to the latest version to ensure the accuracy of the table below. SATA HDD should be used for the DVR with SATA port. ADT recommends a HDD of 500GB to 4TB capacity.

Manufacturer	Series	Model	Capacity	Port Mode
Hitachi	HitachiCinemaStar™ 5K500	HCP725050GLA380	500G	SATA
Hitachi	HitachiCinemaStar™ 7K1000.B	HCT721050SLA360	500G	SATA
Hitachi	HitachiCinemaStar™ 7K1000.B	HCT721075SLA360	750G	SATA
Hitachi	HitachiCinemaStar™ 7K1000.B	HCT721010SLA360	1T	SATA
Maxtor	DiamondMax 20	STM3320820AS	320G	SATA
Maxtor	DiamondMax 20	STM3250820AS	250G	SATA
Samsung	Samsung—HA	HA500LJ/CE	500G	SATA
Samsung	Samsung—HA	HA751LJ	750G	SATA
Samsung	Samsung—HA	HA101UJ/CE	1T	SATA
Samsung	Samsung—HD	HD502HI/CEC	500G	SATA
Samsung	Samsung—HD	HD103SI/CEC	1T	SATA
Samsung	Samsung—HD	HD154UI/CE	1.5T	SATA
Seagate	Seagate SV35.1	ST3250824SV	250G	SATA
Seagate	Seagate SV35.1	ST3500641SV	500G	SATA
Seagate	Seagate SV35.2	ST3250820SV	250G	SATA
Seagate	Seagate SV35.2	ST3320620SV	320G	SATA
Seagate	Seagate SV35.2	ST3500630SV	500G	SATA
Seagate	Seagate SV35.2	ST3750640SV	750G	SATA
Seagate	Seagate SV35.3	ST3250310SV	250G	SATA
Seagate	Seagate SV35.3	ST3500320SV	500G	SATA
Seagate	Seagate SV35.3	ST3750330SV	750G	SATA
Seagate	Seagate SV35.3	ST31000340SV	1T	SATA
Seagate	Seagate SV35.4	ST3320410SV	320G	SATA
Seagate	Seagate SV35.4	ST3250311SV	250G	SATA
Seagate	Seagate SV35.5	ST3500410SV	500G	SATA

Manufacturer	Series	Model	Capacity	Port Mode
Seagate	Seagate SV35.5	ST3500411SV	500G	SATA
Seagate	Seagate SV35.5	ST31000525SV	1T	SATA
Seagate	Seagate SV35.5	ST31000526SV	1T	SATA
Seagate	Seagate SV35.5	ST1000VX000	1T	SATA
Seagate	Seagate SV35.5	ST2000VX003	2T	SATA
Seagate	Seagate SV35.5	ST2000VX002	2T	SATA
Seagate	Seagate SV35.5	ST2000VX000	2T	SATA
Seagate	Seagate SV35.5	ST3000VX000	3T	SATA
Seagate	Seagate Pipeline HD	ST3320410CS	320G	SATA
Seagate	Seagate Pipeline HD	ST3320310CS	320G	SATA
Seagate	Seagate Pipeline HD	ST3500422CS	500G	SATA
Seagate	Seagate Pipeline HD	ST3500321CS	500G	SATA
Seagate	Seagate Pipeline HD2	ST3250412CS	250G	SATA
Seagate	Seagate Pipeline HD2	ST3320311CS	250G	SATA
Seagate	Seagate Pipeline HD2	ST3500414CS	500G	SATA
Seagate	Seagate Pipeline HD2	ST3500312CS	500G	SATA
Seagate	Seagate Pipeline HD2	ST31000424CS	1T	SATA
Seagate	Seagate Pipeline HD2	ST31000322CS	1T	SATA
Seagate	Seagate Pipeline HD2	ST1000VM002	1T	SATA
Seagate	Seagate Pipeline HD2	ST1500VM002	1T	SATA
Seagate	Seagate Pipeline HD2	ST2000VM002	2T	SATA
Seagate	Seagate Pipeline HD2	ST2000VM003	2T	SATA
Seagate	Seagate Constellation ES	ST3500514NS	500G	SATA
Seagate	Seagate Constellation ES	ST31000524NS	1T	SATA
Seagate	Seagate Constellation ES	ST32000644NS	2T	SATA
Seagate	Seagate Constellation ES	ST2000NM0011	2T	SATA
Seagate	Seagate Constellation ES	ST1000NM0011	1T	SATA
Seagate	Seagate Constellation ES	ST500NM0011	500G	SATA
Seagate	Seagate Constellation ES	ST2000NM0031	2T	SATA
Seagate	Seagate Constellation ES	ST1000NM0031	1T	SATA
Seagate	Seagate Constellation ES	ST500NM0031	500G	SATA
Seagate	Seagate Constellation ES	ST2000NM0051	2T	SATA
Seagate	Seagate Constellation ES	ST1000NM0051	1T	SATA
Seagate	Seagate Constellation ES	ST500NM0051	500G	SATA
Seagate	Seagate Constellation ES.2	ST33000650NS	3T	SATA
Seagate	Seagate Constellation ES.2	ST32000645NS	2T	SATA
Seagate	Seagate Constellation ES.2	ST33000651NS	3T	SATA

Manufacturer	Series	Model	Capacity	Port Mode
Seagate	Seagate Constellation ES.2	ST32000646NS	2T	SATA
Seagate	Seagate Constellation ES.2	ST33000652NS	3T	SATA
Seagate	Seagate Constellation ES.2	ST32000647NS	2T	SATA
Western Digital	Cariar SE	WD3200JD	320G	SATA
Western Digital	Cariar SE	WD3000JD	300G	SATA
Western Digital	Cariar SE	WD2500JS	250G	SATA
Western Digital	Cariar SE16	WD7500KS	750G	SATA
Western Digital	Cariar SE16	WD5000KS	500G	SATA
Western Digital	Cariar SE16	WD4000KD	400G	SATA
Western Digital	Cariar SE16	WD3200KS	320G	SATA
Western Digital	Cariar SE16	WD2500KS	250G	SATA
Western Digital	WD Caviar SE16	WD2500YS-01SHB0	250G	SATA
Western Digital	WD Caviar RE16	WD3200YS-01PGB0	320G	SATA
Western Digital	WD Caviar RE2	WD5000YS-01MPB0	500G	SATA
Western Digital	WD AV—AVJS	WD2500AVJS-63WDA0	500G	SATA
Western Digital	WD AV—AVJS	WD3200AVJS-63WDA0	320G	SATA
Western Digital	WD AV—AVJS	WD5000AVJS-63YJA0	500G	SATA
Western Digital	WDAV-GP—AVCS	WD5000AVCS-63H1B1	500G	SATA
Western Digital	WDAV-GP—AVCS	WD7500AVCS-63ZLB0	750G	SATA
Western Digital	WDAV-GP—AVCS	WD3200AVCS	320G	SATA
Western Digital	WDAV-GP—AVCS	WD2500AVCS	250G	SATA
Western Digital	WDAV-GP—EVCS	WD10EVCS-63ZLB0	1T	SATA
Western Digital	WDAV-GP—EVCS	WD20EVCS-63ZLB0	2T	SATA
Western Digital	WDAV-GP—AVVS	WD3200AVVS-63L2B0	320G	SATA
Western Digital	WDAV-GP—AVVS	WD5000AVVS-63ZWB0	500G	SATA
Western Digital	WDAV-GP—AVVS	WD7500AVVS-63E1B1	750G	SATA
Western Digital	WDAV-GP—AVVS	WD7500AVVS-63E1B1	750G	SATA
Western Digital	WDAV-GP—EVVS	WD10EVVS-63E1B1	1T	SATA
Western Digital	WDAV-GP—EVDS	WD10EVDS-63N5B1	1T	SATA
Western Digital	WDAV-GP—EVDS	WD15EVDS-63V9B0	1.5T	SATA
Western Digital	WDAV-GP—EVDS	WD20EVDS-63T3B0	2T	SATA
Western Digital	WDAV-GP—AVDS	WD5000AVDS-63U7B0	500G	SATA
Western Digital	WD AV-GP	WD30EURS	3T	SATA
Western Digital	WD AV-GP	WD25EURS	2.5T	SATA
Western Digital	WD AV-GP	WD20EURS	2T	SATA
Western Digital	WD AV-GP	WD15EURS	1.5T	SATA
Western Digital	WD AV-GP	WD10EURS	1T	SATA
Western Digital	WD AV-GP	WD10EURX	1T	SATA
Western Digital	WD AV-GP	WD7500AURS	750G	SATA
Western Digital	WD AV-GP	WD7500AVDS	500G	SATA
Western Digital	WD AV-GP	WD5000AVDS	500G	SATA
Western Digital	WD AV-GP	WD10EUCX	1T	SATA

Appendix D Compatible CD/DVD Device List

Note: Upgrade the DVR firmware to the latest version to ensure the accuracy of the table below.

Manufacturer	Model	Port Type	Type
Sony	DRX-S50U	USB	DVD-RW
Sony	DRX-S70U	USB	DVD-RW
Sony	AW-G170S	SATA	DVD-RW
Samsung	TS-H653A	SATA	DVD-RW
Panasonic	SW-9588-C	SATA	DVD-RW
Sony	DRX-S50U	USB	DVD-RW
BenQ	5232WI	USB	DVD-RW

Appendix E Compatible Display List

Refer to the following table for compatible displays.

Brand	Model	Dimension (in inches)
BENQ (LCD)	ET-0007-TA	19-inch (wide screen)
DELL (LCD)	E178FPc	17-inch
BENQ (LCD)	Q7T4	17-inch
BENQ (LCD)	Q7T3	17-inch
LENOVO (LCD)	LXB-L17C	17-inch
SANGSUNG (LCD)	225BW	22-inch (wide screen)
HFNOVO (CRT)	LXB-FD17069HB	17-inch
HFNOVO (CRT)	LXB-HF769A	17-inch
HFNOVO (CRT)	LX-GJ556D	17-inch
Samsung (LCD)	2494HS	24-inch
Samsung (LCD)	P2350	23-inch
Samsung (LCD)	P2250	22-inch
Samsung (LCD)	P2370G	23-inch
Samsung (LCD)	2043	20-inch
Samsung (LCD)	2243EW	22-inch
Samsung (LCD)	SMT-1922P	19-inch
Samsung (LCD)	T190	19-inch
Samsung (LCD)	T240	24-inch
LG (LCD)	W1942SP	19-inch
LG (LCD)	W2243S	22-inch
LG (LCD)	W2343T	23-inch
BENQ (LCD)	G900HD	18.5-inch
BENQ (LCD)	G2220HD	22-inch
PHILIPS (LCD)	230E	23-inch
PHILIPS (LCD)	220CW9	23-inch
PHILIPS (LCD)	220BW9	24-inch
PHILIPS (LCD)	220EW9	25-inch

Appendix F Compatible Switcher List

Refer to the following table for compatible switchers.

Brand	Model	Network Working Mode
D-Link	DES-1016D	10/100M self-adaptive
D-Link	DES-1008D	10/100M self-adaptive
Ruijie	RG-S1926S	There are five network modes AUTO HALF-10M FULL-10M HALF-100M FULL-100M
H3C	H3C-S1024	10/100M self-adaptive
TP-LINK	TL-SF1016	10/100M self-adaptive
TP-LINK	TL-SF1008+	10/100M self-adaptive

Appendix G Compatible Wireless Mouse List

Refer to the following table for compatible devices.

Brand	Model
SUNT 仕拓	V80
Rapoo	3500
Logitech	M215
Shuangfeiyan	Tianyao G7-630

Index

A

Abnormality, *74, 131*
 Account Setup, *75, 144*
 Adjust Screen, *79, 149*
 Advanced Menu, *71, 156*
 Alarm, *105*
 Auto Maintenance, *79, 155*
 Auto Network Registration, *66, 123*

B

Backup, *37, 104*
 Backup Device List, *170*
 BPS, *86*

C

Camera Masking, *34, 129*
 CD/DVD List, *174*
 Channel
 Name, *68, 111*
 Setup, *105*
 Synchronization, *15*
 Compatible
 Backup Device List, *170*
 CD/DVD Device List, *174*
 Display List, *175*
 Switcher List, *176*
 Wireless Mouse List, *177*
 Config Backup, *83*
 Connection Setup
 Network, *114*
 Context Menu, *3*
 Copy Setup, *22, 47, 135*

D

Date and Time Setup, *42, 142*
 DDNS Setup, *57, 115*
 Default Settings, *70, 154*
 Detect Menu, *26, 124*
 Camera Masking, *34, 129*
 Motion Detection, *29, 124*
 Video Loss, *32, 127*
 Disk Error, *74, 131*
 Display
 List, *175*
 Setup, *68, 148*
 DVR
 Context Menu, *3*
 Features, *vii*
 Front Panel, *1*
 Installation, *ix*
 Keyboard, *3*
 Overview, *1*
 Rear Panel, *1*
 Specifications, *167*
 Virtual Keyboard, *3*

E

Email Setup, *60, 118*
 Encode Setup, *45, 107*
 Event, *124*
 Export, *83, 154*

F

Features, *vii*
 Front Panel, *1*
 FTP Setup, *62, 139*

G

General Setup, *42, 141*
 GUI Setup, *148*

H

HDD Information, *85*
 HDD Management, *71*
 HDD Setting, *72, 137*
 Holiday
 Schedule, *21, 136*
 Setup, *44, 143*

I

Import, *83, 154*
 Information, *84, 160*
 Installation, *ix*
 IP Conflict, *74, 133*
 IP Filter, *52, 117*

K

Keyboard, *3*

L

Live Viewing Mode, *7, 94*
 Log, *86, 160*
 Login, *4, 92*
 Logout, *6, 162*

M

MAC Conflict, *74, 134*
 Main Menu, *41*
 Maintenance, *163*
 Manual Recording, *8, 96, 99, 140*
 Mark Playback, *18*
 Menu, *40*
 Advanced
 Abnormality, *74*
 Account, *75*
 Auto Maintain, *79*
 Config Backup, *83*
 HDD Management, *71*
 Record, *8*
 Text Overlay, *80*

- TV Adjust, 79
 - Info, 84
 - BPS, 86
 - HDD Info, 85
 - Log, 86
 - Network Info, 89
 - Online Users, 88
 - Version, 87
 - Main, 41
 - Search, 12
 - Setting, 41
 - Default, 70
 - Detect, 26
 - Display, 68
 - Encode, 45
 - General, 42
 - Network, 49
 - Schedule, 20
 - Shutdown, 91
 - Tree, 40
 - Motion Detection, 29, 124
 - Smart Search, 16
 - Mouse
 - Click Speed, 44
 - List, 177
 - Multicast, 55, 122
- N**
- Network
 - Disconnection, 74, 132
 - Information, 89
 - Priority Setup, 66
 - Network Setup, 49
 - Auto Register, 66, 123
 - Connection, 50, 114
 - DDNS, 57, 115
 - Email, 60, 118
 - FTP, 62, 139
 - IP Filter, 52, 117
 - Multicast, 55, 122
 - NTP, 54, 143
 - PPPoE, 56, 115
 - Priority, 66
 - SNMP, 65, 121
 - TCP/IP, 112
 - UPnP, 59, 120
 - Web Service, 112
 - No Disk, 74, 131
 - No Disk Space, 74, 132
 - NTP Setup, 54, 143
- O**
- Online User, 88, 161
 - Overlay
 - Text, 80, 156
 - Video, 46, 110
 - Overview, 1
- P**
- Playback, 12, 17, 100
 - by Time, 17
 - Mark, 18
 - PPPoE Setup, 56, 115
- R**
- Real-time Monitor, 7, 100
 - Rear Panel, 1
 - Recording
 - Manual, 8, 96, 99
 - Schedule, 10, 134
- S**
- Schedule, 20
 - Holiday, 21, 136
 - Quick Setup, 22
 - Recording, 10, 134
 - Snapshot, 22, 136
 - Screen Adjust, 79
 - Search and Playback, 12, 100
 - Setup
 - Abnormality, 131
 - Account, 144
 - Auto Maintain, 155
 - Camera Masking, 129
 - Channel Name, 111
 - Date and Time, 142
 - Default, 154
 - Display, 148
 - Encode, 107
 - FTP, 139
 - GUI, 148
 - Holiday, 44, 143
 - Import & Export, 154
 - Log, 160
 - Motion Detection, 124
 - Online User, 161
 - Snapshot, 109
 - Tour, 150
 - TV Adjust, 149
 - Upgrade, 155
 - Video, 107
 - Video Loss, 127
 - Video Overlay, 110
 - Web Service, 105
 - Shutdown, 91
 - Smart Search
 - Motion Detection, 16
 - Snapshot, 22
 - Activation, 24
 - FTP Upload, 26
 - Schedule, 22, 136
 - Setup, 22, 109
 - SNMP Setup, 65, 121
 - Specifications, 167
 - Startup, 6
 - Storage Settings
 - Web Service, 134
 - Switcher List, 176
 - Synchronization, 15
 - System Settings
 - Web Service, 141

T

TCP/IP, *52, 112*
Text Overlay, *80, 156*
Tour Setup, *28, 150*
Troubleshooting, *163*
TV Adjust, *79, 149*

U

Uninstall
 Web Service, *162*
Upgrade, *155*
UPnP Setup, *59, 120*

V

Version, *87, 160*
Video Loss, *32, 127*
Video Overlay, *46, 110*
Video Setup, *107*
Virtual Keyboard, *3*

W

Web Service, *92*
 Abnormality, *131*
 Alarm, *105*
 Channel Setup, *105*
 Event, *124*
 Information, *160*
 Live Mode, *94*
 Login, *92*
 Logout, *162*
 Network, *112*
 Playback, *100*
 Real time Monitor, *100*
 Search, *100*
 Setup, *105*
 Storage Settings, *134*
 System Settings, *141*
 Uninstall, *162*
 Version, *160*
 Video Detect, *124*
Wireless Mouse List, *177*